

# WHEELER-REX

ELECTRIC PIPE THREADING MACHINE

# 8991 (F25A)

## Parts List

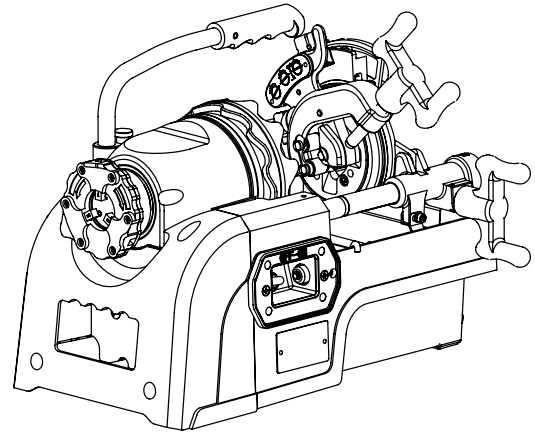
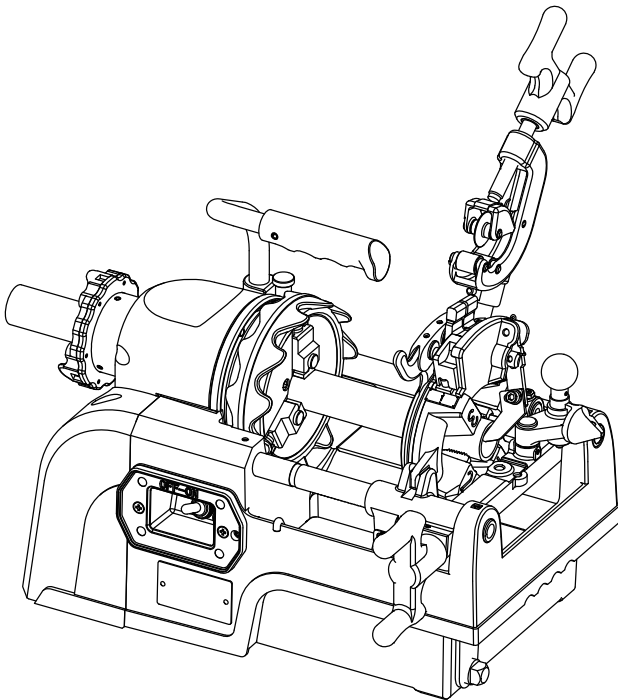

### CONTENTS

1. Base
2. Main Shaft, Motor
3. Carriage
4. Cutter / Reamer
5. Self-opening die head  
10A / 25A (1/4-3/8", 1/2-1")



# 8991

## 1. Base

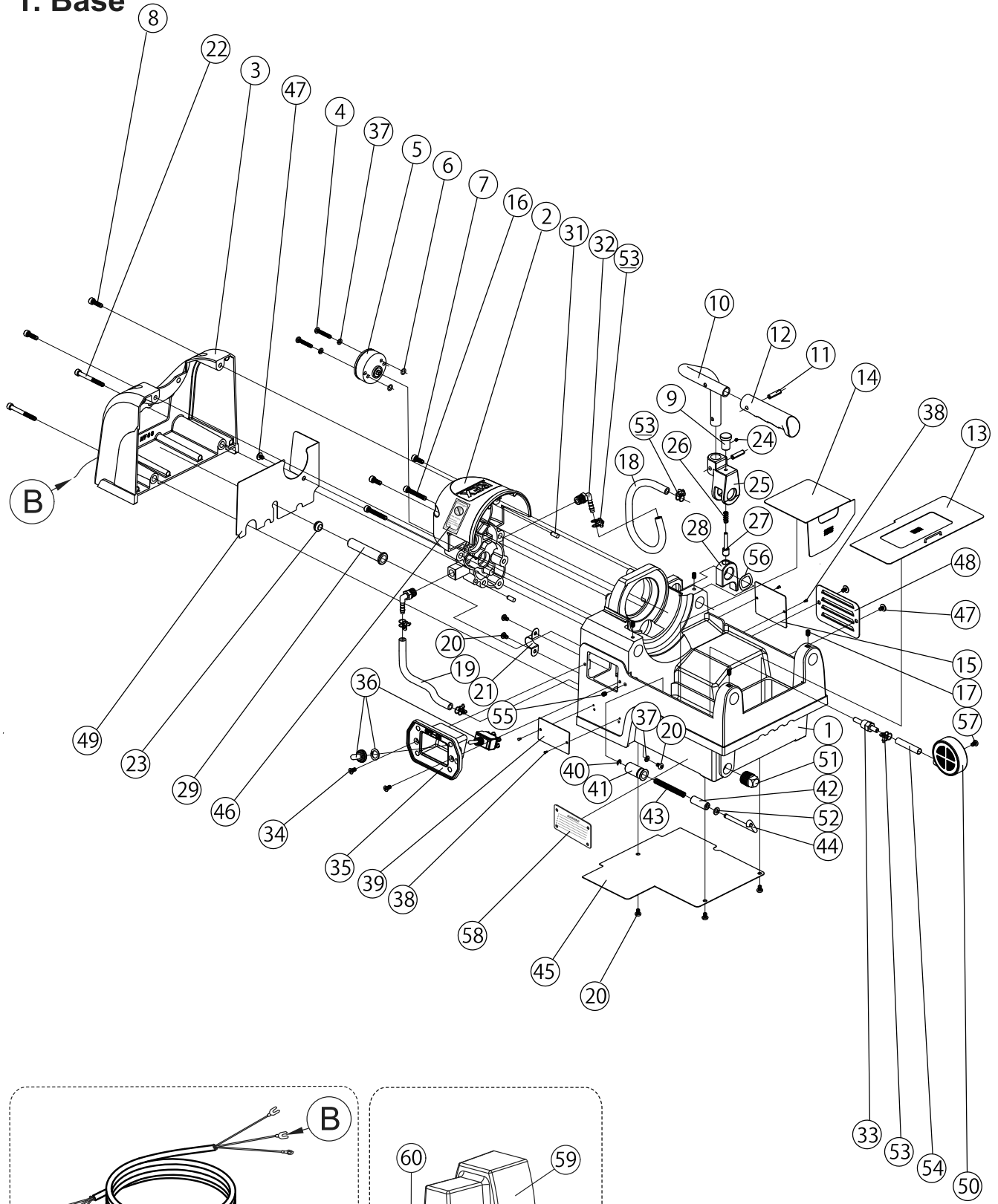

Item No.	Part No. (Wheeler)	Part Name	Spec	Q'ty	Compatibility with 7991	Part No.(REX)	Remarks
1	600302	Base		1	x	MF01	
2	600303	Transmission case		1	x	MF02	
3	600304	Rear cover		1	x	MF03	
4	600341	Pan head machine screw	(M5×30)	2	o	W256	
5	602007	Gear pump		1	o	TY37C	6991, 7991
6	601566	O-ring	(P7)	2	o	Z507	
7	600131	Hex socket head cap screw	(M6×16)	2	x	W062	
8	600486	Hex socket head cap screw	(M6×20)	2	x	W063	
9	606527	Carrying handle movable block fix pin		1	o	MYA3	
10	600305	Carrying handle		1	x	MF11	
11	600957	Roll pin	(6×25)	2	o	WL6B	
12	606529	Carrying handle grip		1	o	MY28	
13	600606	Scrap receiver (L)		1	x	MF05	
14	600307	Scrap receiver (S)		1	x	MF06	
15	606532	Plate (for changing carbon brushes)		1	x	MY91C	
16	609736	Hex socket head cap screw	(M6×40)	2	x	W067	
17	606534	Hex socket set screw	(cone point, M6×10)	4	o	W663	
18	601537	Oil line tube R(Feed)	(340mm/Red)	1	o	0410-340	
19	600630	Oil line tube R(Intake)	(175mm/Red)	1	o	0410-175	
20	600329	Pan head machine screw	(M5×8)	6	o	W251	
21	606454	Saddle clamp	(C-15)	1	o	7098	6890, 6790, 6590, 7090, 7991
22	606465	Hex socket head cap screw	(M6×55)	2	o	W069	
23	600308	Grommet	(BU-687-C)	1	x	MF16	
24	600309	Hex socket set screw	(cone point, M4×5)	1	o	W645	Old Rex No. #0025
25	600310	Carrying handle movable block		1	x	MF13	
26	606538	Carrying handle fixed spring		1	o	MY32	
27	606539	Carrying handle fixed pin guide		1	o	MYA4	
28	606540	Carrying handle fixed block		1	o	MYA2	Old Rex No. MY90
29	606541	Cord bush	(115/120V/220V)	1	o	TY25	
30	606542	Cabtyre cord for motor	(115V)	1	o	Z992	
31	606543	Parallel pin	(B-type 6×15)	2	o	WN09	
32	600311	Hose elbow	(R1/4)	2	x	MF14	
33	600730	Nipple		1	o	T056	
34	606546	Oval head machine screw	(M5×10)	2	o	W346	
35	600312	Switch case		1	x	MF07	
36	606548	Switch		1	o	MY20C	
37	600124	Spring washer	(5)	3	o	WG05	
38	600621	Rivet	(#4×5)	4	o	WN34	
39	600313	Name plate	WH	1	x	MF20	not for sale
40	606551	Snap ring	(4)	1	o	WY04	
41	606552	Spring receptacle B		1	o	MY39	
42	606553	Spring receptacle C		1	o	MY40	
43	606554	Spring		1	o	MY43	
44	606555	Adjustment bar		1	o	MY41	
45	600314	Bottom cover		1	x	MF10	
46	600315	Caution sticker		1	o	9A46	
47	600316	Truss machine screw	(M5×8)	3	o	W558	
48	600317	Side cover		1	x	MF08	
49	600318	Partition		1	x	MF09	
50	600731	Strainer	with 600732	1	o	N048	6991, 7991
51	600145	Drain Plug	(R1/2)	1	o	WA46	6790, 6590, 7991
52	600211	Flat washer	(6)	1	x	W162	
53	600213	Pipe Band S	(10mm)	5	o	ZJ50	
54	600319	Tank Hose	45mm / Red	1	x	0410-45	
55	600939	Hex socket set screw	(M6×8, cone point)	1	o	W662	
56	600320	Wave washer	(22)	1	x	WH22	
57	600732	Pan head tapping screw	(M5×8)	1	o	WA55	6991, 7991
58	606456	Warning plate (English)		1	o	L099	not for sale
59	901	Foot switch	115V	1set	o	—	7991, 8090
60	600139	Foot switch wire		1	o	—	7991, 8090

## 2. Main Shaft, Motor

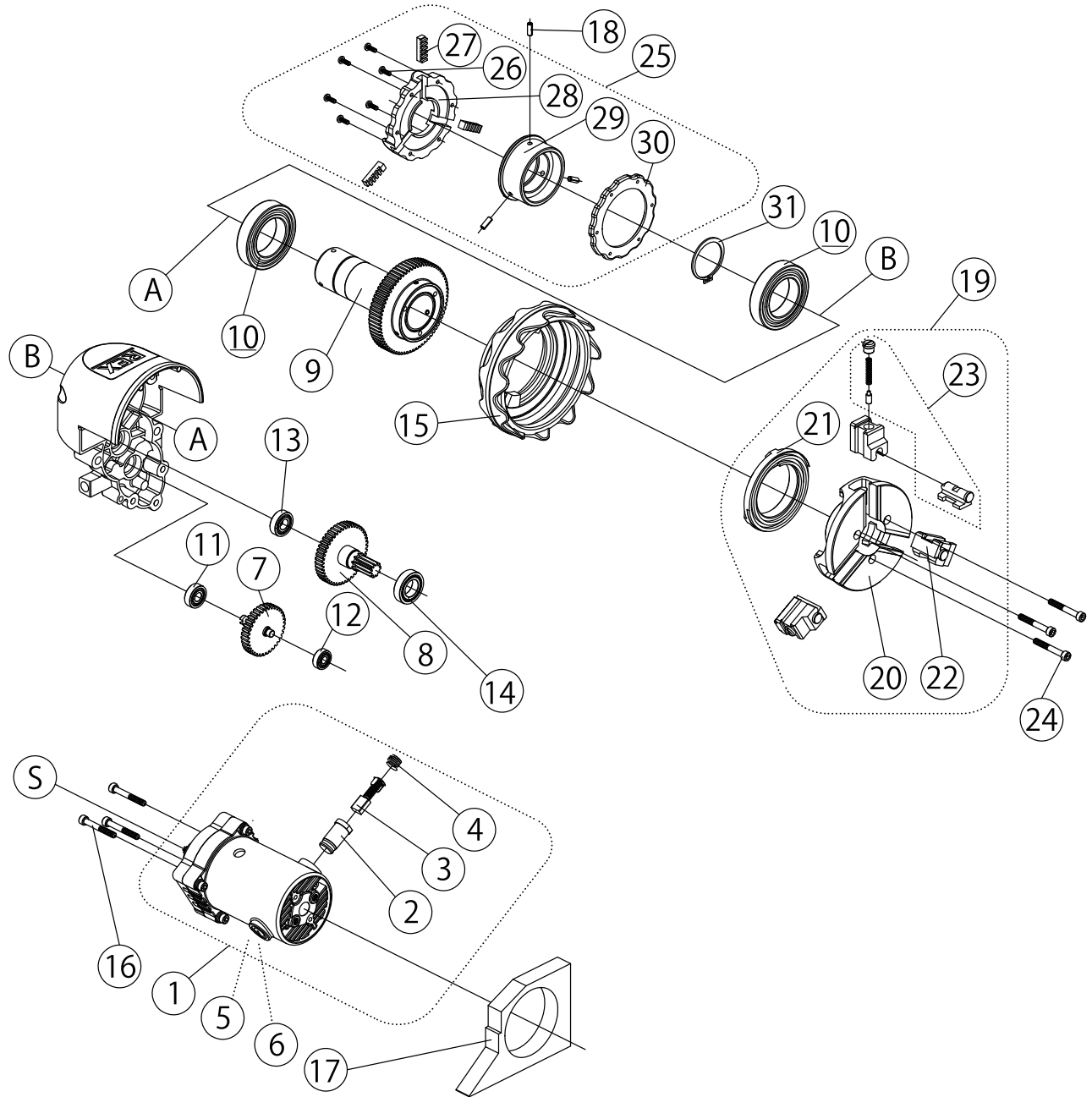

\* Motor (S) goes into B.

Item No.	Part No. (Wheeler)	Part Name	Spec	Q'ty	Compatibility with 7991	Part No.(REX)	Remarks
1	600321	Motor	(115V/Black )	1	o	MY9AT	
2	600322	Carbon brush holder		2	o	G2M16	
3	606665	Carbon brush		1set	o	MYM2	2pcs/set
4	600323	Carbon brush cap		2	o	G2M17	
5	606880	Armature assembly	(115V)	1	o	G2M02	
6	606668	Stator assembly	(115V)	1	o	G2M06	
7	606837	First gear assembly		1	o	MY05C	
8	606838	Second gear assembly		1	o	MY07C	
9	606839	Main shaft with gear		1	o	02MY	
10	606675	Bearing	(6009ZZ)	2	o	MY0A	
11	606676	Bearing	(6000ZZ)	1	o	S374	
12	606677	Miniature bearing	(608ZZ)	1	o	S373	
13	606678	Bearing	(6001ZZ)	1	o	J300	
14	606679	Bearing	(6904ZZ)	1	o	MY0B	
15	606680	Hand wheel		1	o	MY16	
16	W06K	Hex socket head cap screw	(M6×45/Green Mec)	3	o	W06K	
17	600324	Insulation sponge		1	x	MF12	
18	600665	Grooved pin	(5×14)	3	o	WM52C	
19	602101	Complete chuck assembly		1set	o	KY04	
20	602102	Chuck body		1	o	TYH0	
21	TYS0	Chuck scroll	7991/8991	1	o	TYS0	
22	600326	Chuck jaw set	RT-NS	1set	o	H0CJS	3pcs each/set incl. G0NS / 7991
23	602103	Chuck jaw insert set	NS	1set	o	G0NS	3pcs each/set
24	600156	Hex socket head cap screw	(M6×45)	3	o	W068	
25	606682	Complete rear chuck assembly		1set	o	MY17	
26	606683	Pan head machine screw	(M4×12)	6	o	W24C	
27	606684	Rear chuck jaw		1set	o	MYSS	
28	606685	Rear chuck receptacle		1	o	MYS1	
29	606686	Rear scroll		1	o	MYS3	
30	606687	Rear chuck cover		1	o	MYS2	
31	600995	Snap ring	(out side 45)	1	o	WW45	

8991

3. Carriage

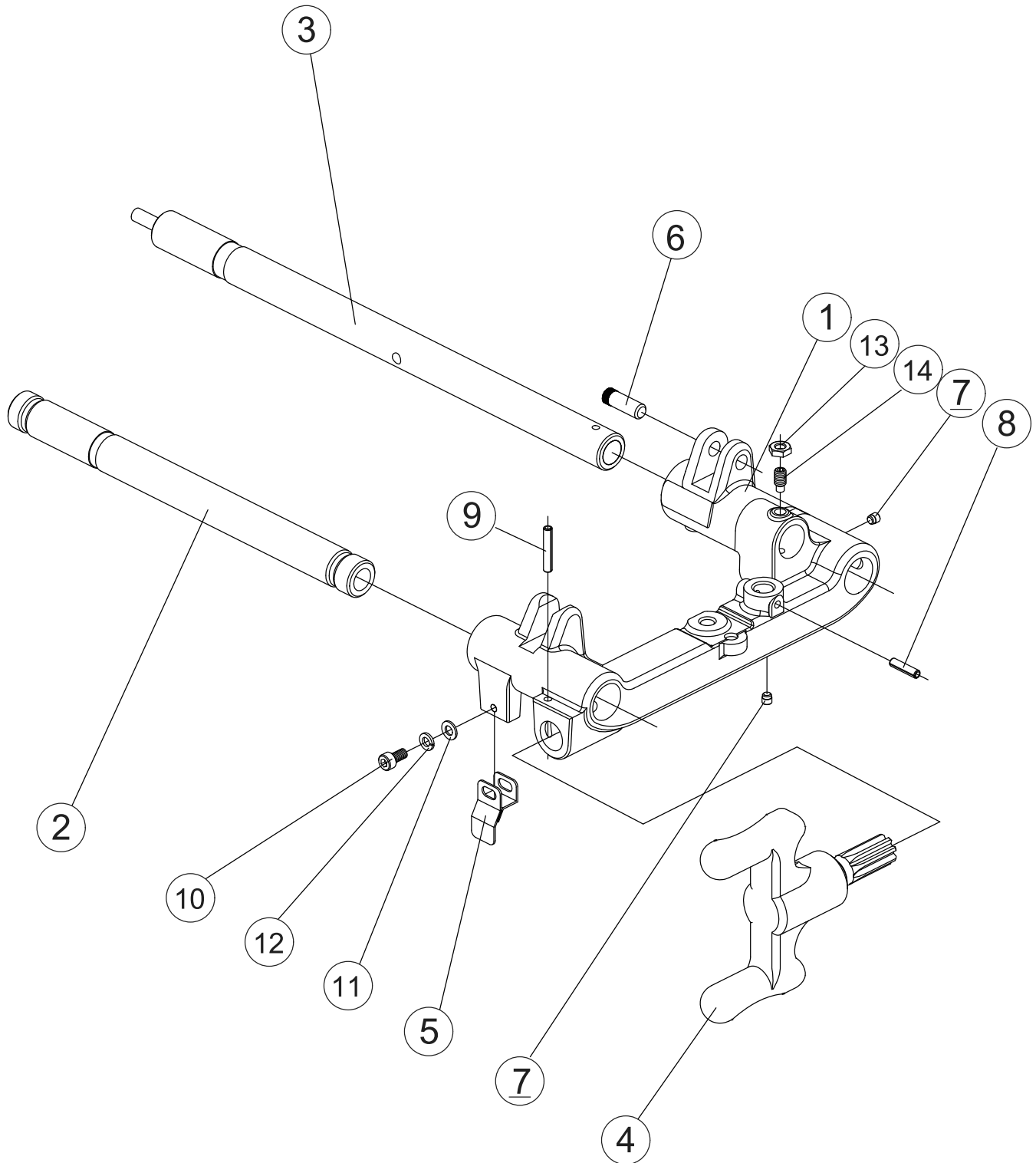

## 8991 3. Carriage

2018/4/17

Item No.	Part No. (Wheeler)	Part Name	Spec	Q'ty	Compatibility with 7991	Part No.(REX)	Remarks
1	606689	Carriage		1	o	MY33	
2	606690	Carriage support bar A		1	o	MY14	
3	600327	Carriage support bar B		1	x	MF04	
4	606692	Carriage handle		1	o	MY34	
5	606693	Size adjustment plate		1	o	MY44	
6	600989	Cutter arm stop pin		1	o	HY62	6991, 7991
7	600988	Oil cap		2	o	HY49	6991, 7991
8	606695	Roll pin	(4×18)	1	o	WL45	
9	600658	Roll pin	(4×25)	1	o	WL47	
10	606688	Hex socket head cap screw	(M5×10)	1	o	W052	
11	600248	Flat washer	(5)	1	o	WI52	
12	600124	Spring washer	(5)	1	o	WG05	
13	600811	Jam nut	(M6)	1	o	WD06	
14	600176	Hex-socket set screw	(M6×12, dog point)	1	o	W865	

## 4. Cutter/Reamer

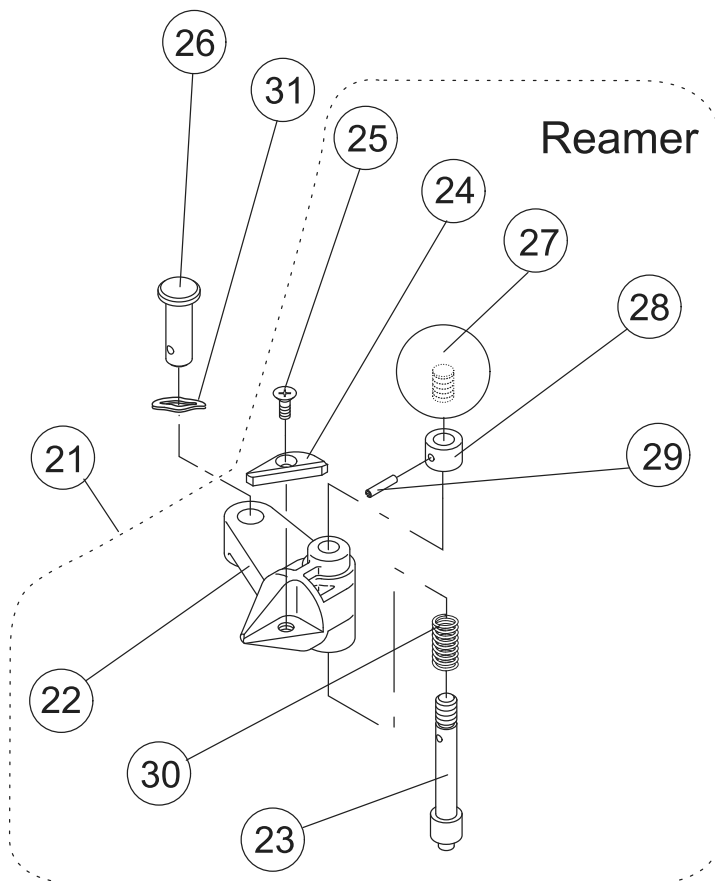
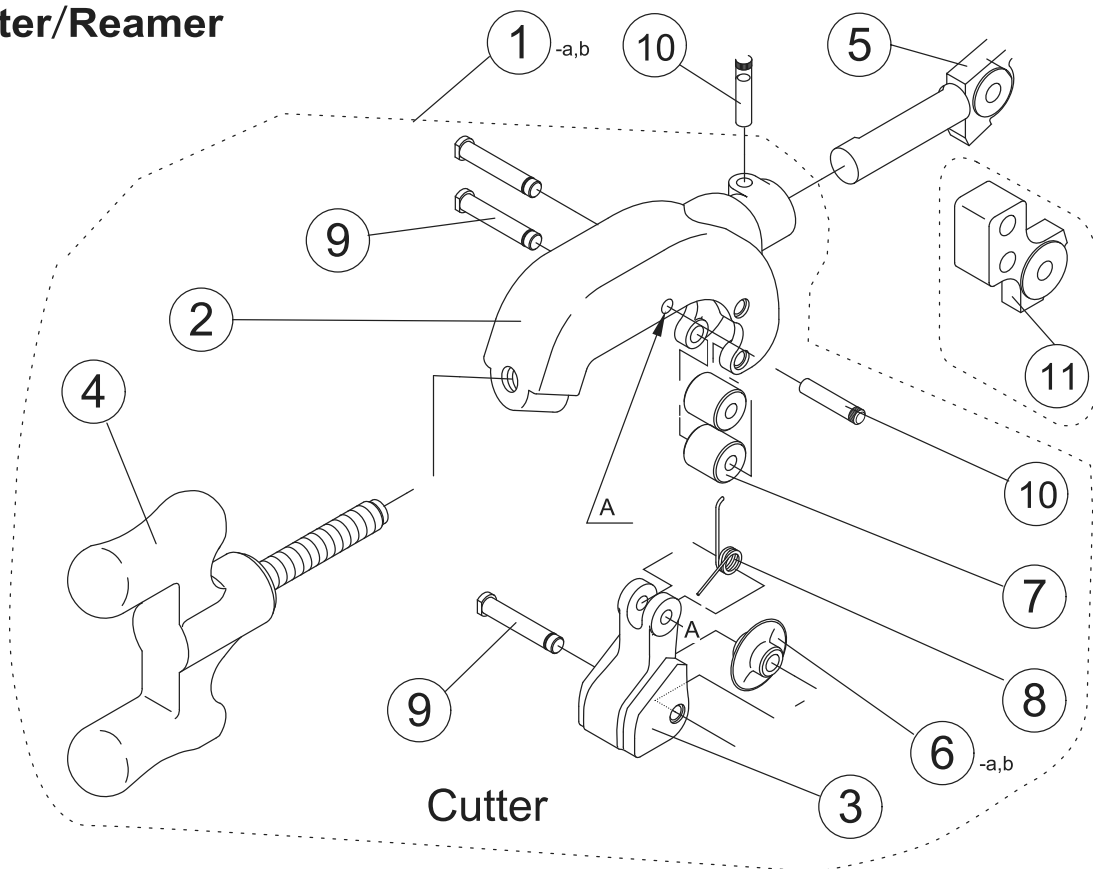



Item No.	Part No. (Wheeler)	Part Name	Spec	Q'ty	Compatibility with 7991	Part No.(REX)	Remarks
1-a	606697	Complete cutter assembly (No.2-10)	with 606700 and 602023	1 set	o	0MCU1S	with 60322
1-b	600331	Complete cutter assembly (No.2-10)	SUS	1 set	o	0MCU2S	with 62322 (option)
2	606696	Cutter frame		1	o	MY45	
3	606698	Cutter guide		1	o	MY46	
4	606699	Cutter handle		1	o	MY48	
5	606700	Cutter arm		1	o	MY47	
6-a	60322	Cutter wheel		1	o	135070	6991,7991/see Product List
6-b	62322	Cutter wheel for stainless steel pipe	SUS	1	o	135071	6991,7991/see Product List (option)
7	602025	Cutter roller		2	o	HY57C	6991, 7991
8	602024	Spring		1	o	HY63	6991, 7991
9	602022	Cutter pin A		3	o	CT07	6991, 7991
10	602023	Cutter frame pin		2	o	HY61	6991, 7991
11	606701	Cutter arm for carbide cutter		1	o	MY93	
21	606702	Complete reamer assembly	with 606707 and 606584	1 set	o	0MRM1S	
22	606703	Reamer body		1	o	MY50	
23	606704	Reamer fixing shaft		1	o	MY54	
24	606705	Reamer blade		1	o	MY52	
25	606706	Flat head machine screw	(M4×8)	1	o	W345	
26	606707	Reamer rotation shaft		1	o	MY53	
27	606708	Reamer grip		1	o	MY56	
28	606709	Reamer fixing shaft collar		1	o	MY55	
29	606710	Roll pin	(3×14)	1	o	WL3A	
30	606711	Reamer fixing shaft spring		1	o	MY94	
31	606584	Wave washer	(WW-12)	1	o	WH12	

## 5. Self Open Die Head 10A / 25A (1/4 - 1")

60136 : 1/4-3/8" NPT (Option)  
 70131 : 1/2- 1" NPT

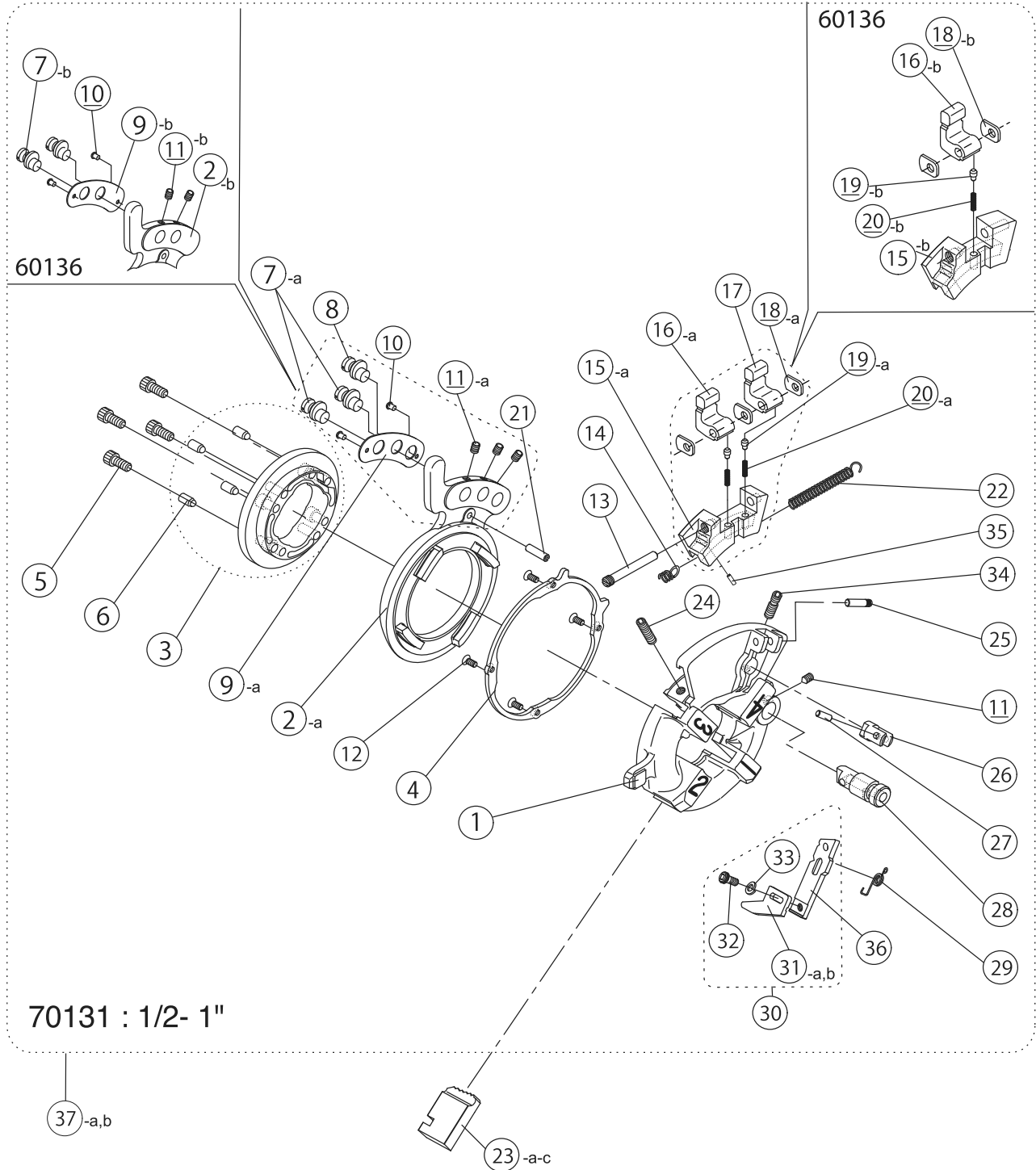

Item No.	Part No. (Wheeler)	Part Name	Spec	Q'ty	Compatibility with 7991	Part No.(REX)	Remarks
1	606712	Die-head body		1	o	MY65	
2-a	606713	Die-head cam plate	for 1/2-1"	1	o	MY66	for 70131
2-b	600333	Die-head cam plate	for 1/4-3/8"	1	o	MY58	for 60136 (option)
3	606714	Die-head retaining ring		1	o	MY67	
4	606715	Die-head ring		1	o	MY71	
5	600131	Hex socket head cap screw		4	o	W062	
6	601576	Dies notch		4	o	G860	
7-a	606716	Eccentric pin A	for 1/2-1"	2	o	MY73	for 70131
7-b	600334	Eccentric pin A	for 1/4-3/8"	2	o	NY61	for 60136 (option)
8	606717	Eccentric pin B		1	o	MY80	
9-a	606718	Adjustment plate	for 1/2-1"	1	o	MY81	for 70131
9-b	600337	Adjustment plate	for 1/4-3/8"	1	o	MY63	for 60136 (option)
10	600621	Rivet		2	o	WN34	
11-a	606719	Hex-socket set screw	(M6×6, cone point)	4	o	W661	for 70131(1/2-1")
11-b	606719	Hex-socket set screw	(M6×6, cone point)	3	o	W661	for 60136 (1/4-3/8", option)
12	609811	Hex socket flat head machine screw	(M4×10)	4	o	W34A	6991, 7991
13	606721	Retaining pin		1	o	MY82	
14	604698	Spring		1	o	7698	6390, 7991
15-a	606722	Opening block	for 1/2-1"	1	o	MY69	for 70131
15-b	600338	Opening block	for 1/4-3/8"	1	o	MY59	for 60136 (option)
16-a	606723	Size setting lever A	for 1/2-1"	1	o	MY70	for 70131
16-b	600339	Size setting lever	for 1/4-3/8"	1	o	MY60	for 60136 (option)
17	606724	Size setting lever B	for 1/2-1"	1	o	MY79	for 70131 only
18-a	606725	Size adjust plate		3	o	MY75	for 70131
18-b	606725	Size adjust plate		2	o	MY75	for 60136 (option)
19-a	604790	Notch pin		2	o	7790	for 70131 / 6390, 7991
19-b	604790	Notch pin		1	o	7790	for 60136 (option) / 6390, 7991
20-a	600687	Spring		2	o	7752	for 70131
20-b	600687	Spring		1	o	7752	for 60136 (option)
21	606726	Roll pin	(5×16)	1	o	WL53	
22	602031	Spring		1	o	MY77	
23-a	60211	Dies 15A-20A (Alloy / NPT)	for NPT 1/2-3/4"	1set	o	161305	see Product List / for 70131, 6991,7991
23-b	60212	Dies 25A (Alloy / NPT)	for NPT 1"	1set	o	161610	see Product List / for 70131, 6991,7991
23-c	60210	Dies 8A-10A (Alloy / NPT)	for NPT 1/4-3/8"	1set	o	16P100	see Product List (option) / for 60136
24	606727	Hex-socket set screw	(M8×18, cup point)	1	o	W785	
25	606728	Auto-open lever pin		1	o	MY83	
26	606730	Auto-open pin		1	o	MY72	
27	606731	Auto-open straight pin		1	o	MY84	
28	606732	Die-head post		1	o	MY78	
29	606733	Auto-open lever spring		1	o	MY76	
30	606734	Auto-open lever set		1 set	o	#0027	No.68+31-33/set
31-a	606735	Auto-open lever B	for NPT1/2-1"	1	o	MY57	for 70131
31-b	600340	Auto-open lever B	for NPT1/4-3/8"	1	o	MY62	for 60136 (option)
32	600479	Hex socket head cap screw	(M6×10)	1	o	W060	7090, 7991
33	600132	Spring washer	(6)	1	o	WG06	
34	606736	Auto-open spring receptacle		1	o	MY85	
35	600175	Roll pin	(φ6×18)	1	o	WL63	
36	606840	Auto-open lever A		1	o	MY68	7991
37-a	70131	Die Head Complete Set	NPT 1/2-1"	1	o	290128	for 70131
37-b	60136	Die Head Complete Set	BSPT/NPT1/4-3/8"	1	o	290129	for 60136 (option)



## **WHEELER-REX**

**REX International U.S.A., Inc.**

**P.O.Box 688, 3744 Jefferson Road, Ashtabula, OH44005**

**Ph:440 - 998 - 2788 · Fax.: 440 - 992 - 2925**

**Toll Free: 1 - 800 - 321 - 7950**

**Website: [www.wheelerrex.com](http://www.wheelerrex.com)**