

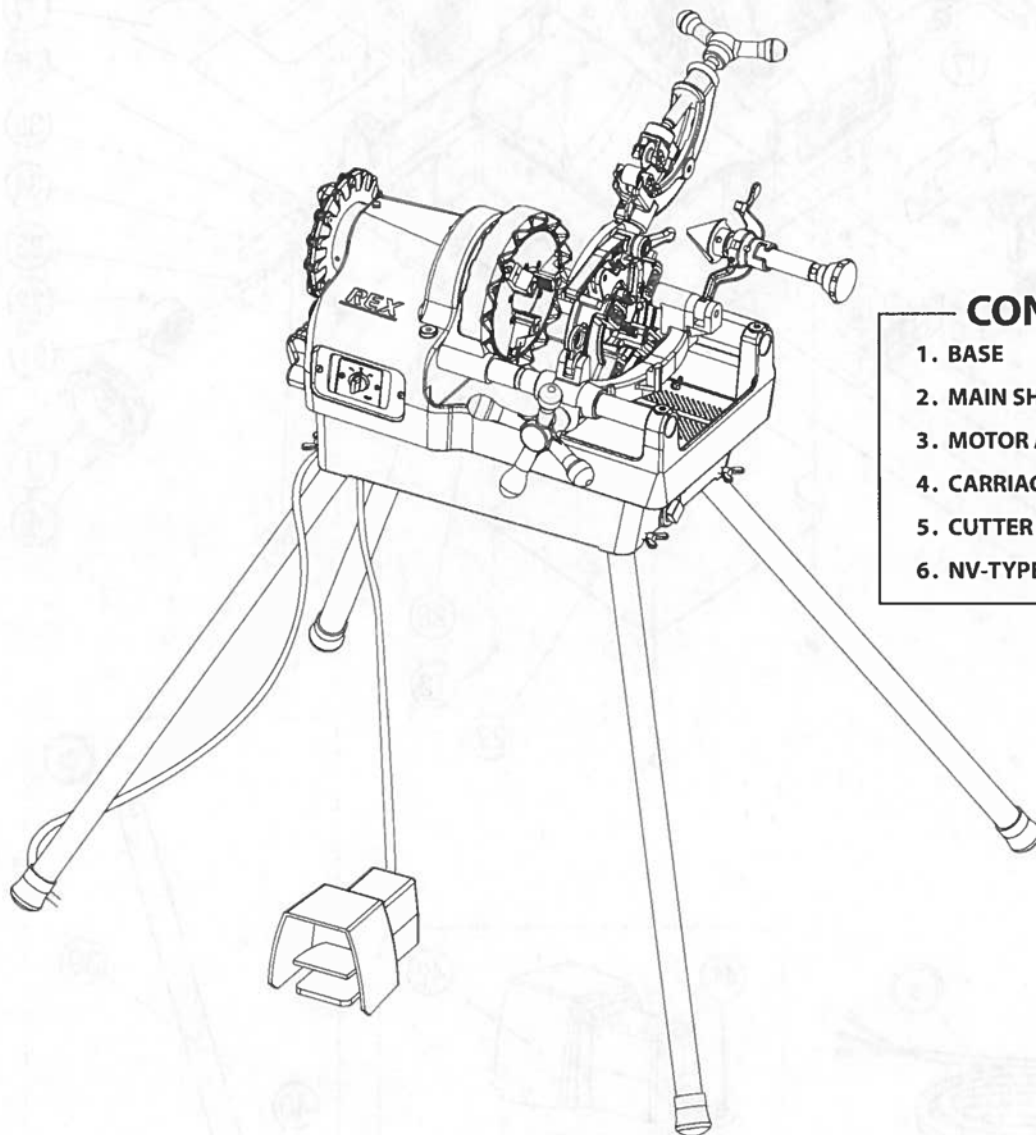

PIPE THREADING MACHINE

8090

PARTS LIST



CONTENTS

1. BASE
2. MAIN SHAFT, MOTOR
3. MOTOR ASSEMBLY
4. CARRIAGE
5. CUTTER, REAMER
6. NV-TYPE DIE HEAD 1/2 - 2

8090 / WHEELER - 1.BASE

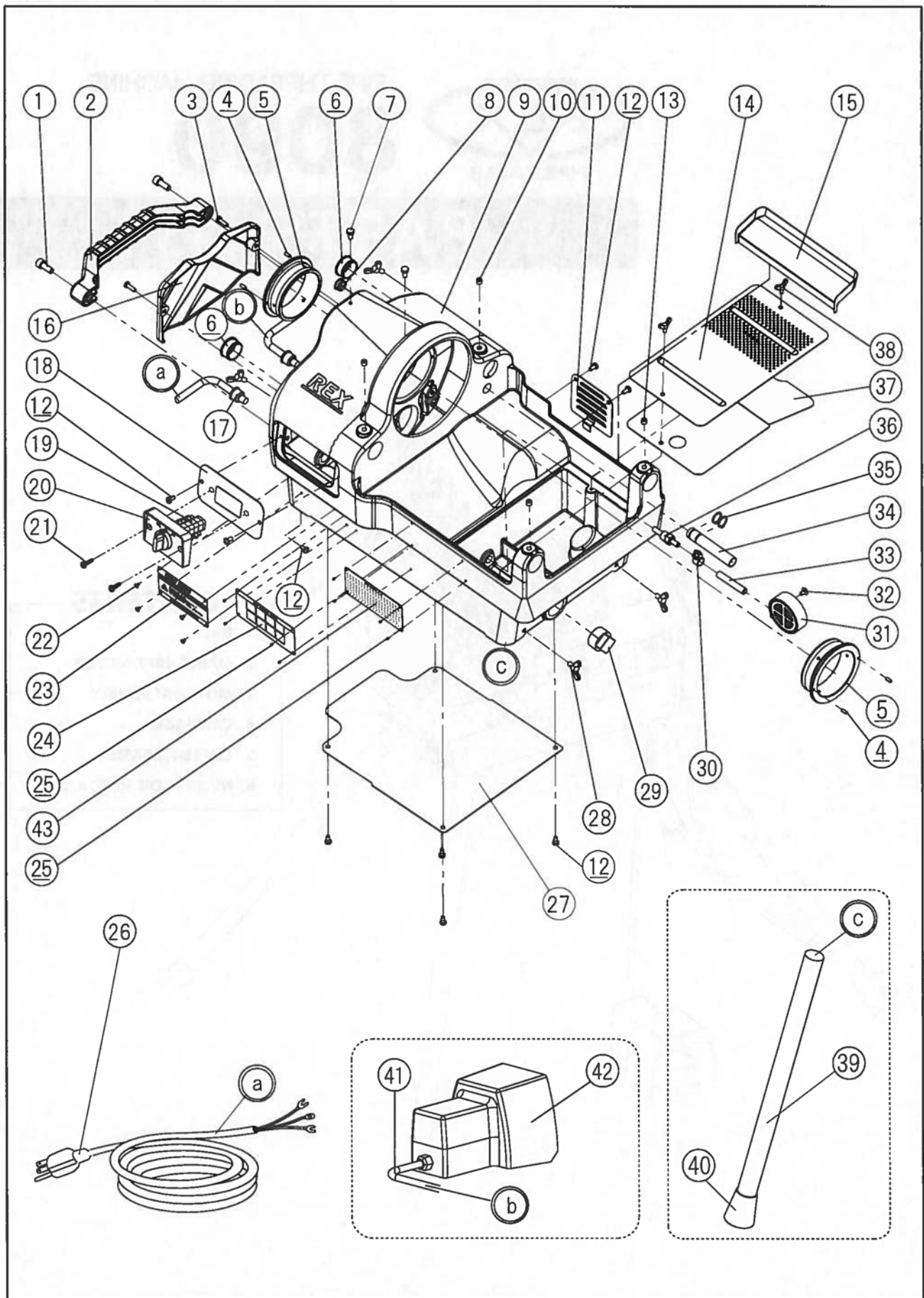

8090 / WHEELER - 1. BASE

2011/6/3

Item No.	WH NO.	Part No.	Part Name	Spec.	Qty	Remarks
1	600129	W083	HEX SOCKET HEAD CAP SCREW	M8×25	2	
2	609708	PM62	REAR GRIP		1	
3	609673	W051	HEX SOCKET HEAD CAP SCREW	M5×16	2	
4	600127	WL41	SPRING PIN	4×10	4	
5	609710	PM97	MAIN SHAFT BEARING		2	
6	609711	PM64	PIPE SUPPORT STOPPER		2	
7	606819	J009	GREASE NIPPLE		2	
8	606457	N054	CAP		1	
9	609712	PM60	BASE CASTING ASSEMBLY		1	
10	609713	W78F	HEX SOCKET SET SCREW	CUP POINT M8×16	2	
11	609714	PM13	SIDE COVER		1	
12	600179	W252	PAN HEAD MACHINE SCREW	M5×10	11	
13	609715	W781	HEX SOCKET SET SCREW	CUP POINT M8×8	2	
14	609716	PM16	SCRAP RECEIVER		1	
15	606523	N624	OIL PAN		1	
16	609717	PM61	REAR COVER		1	
17	609718	PM94	CABLE GRAND		2	
18	609780	PM86	SWITCH ADAPTER PLATE		1	
19	600959	F065	CAM SWITCH	MAIN SWITCH	1	
20	600960	F066	CAM SWITCH PLATE		1	
21	600137	W4A6	OVAL HEAD MACHINE SCREW	M4× 6	2	
22	600184	W241	PAN HEAD MACHINE SCREW	M4× 8	4	
23	609722	PM66	NAME PLATE - 8090	WHEELER	1	
24	609723	PM73	CAUTION PLATE		1	
25	600621	WN34	RIVET	4× 5	8	
26	221389	Z992	CABTYRE CORD		1	
27	609724	PM14	BOTTOM COVER		1	
28	609818	WA83	WING BOLT	M8×30	4	
29	606447	WA42	DRAIN PLUG		1	
30	600213	ZJ50	PIPE BAND	10mm	1	
31	600731	N048	STRAINER		1	
32	600732	WA55	TAPPING SCREW	M5× 8	1	
33	601536	N049	OIL TUBE	55mm	1	
34	609725	PM47	OIL TUBE COVER		1	
35	600854	WW16	SNAP RING	OUTSIDE φ16	2	
36	600730	PN37	NIPPLE		1	
37	609726	PM96	SCRAP RECEIVER B		1	
38	609727	WA68	WING BOLT (Type II)	M5× 8	2	
39	600741	N121C	PIPE STAND		4	
40	603520	N125C	LEG CAP		4	
41	600139	-	FOOT SWITCH WIRE		1	
42	901	-	FOOT SWITCH	115V	1	
43	606456	L099	WARNING PLATE		1	

8090 / WHEELER - 2.MAIN SHAFT, MOTOR

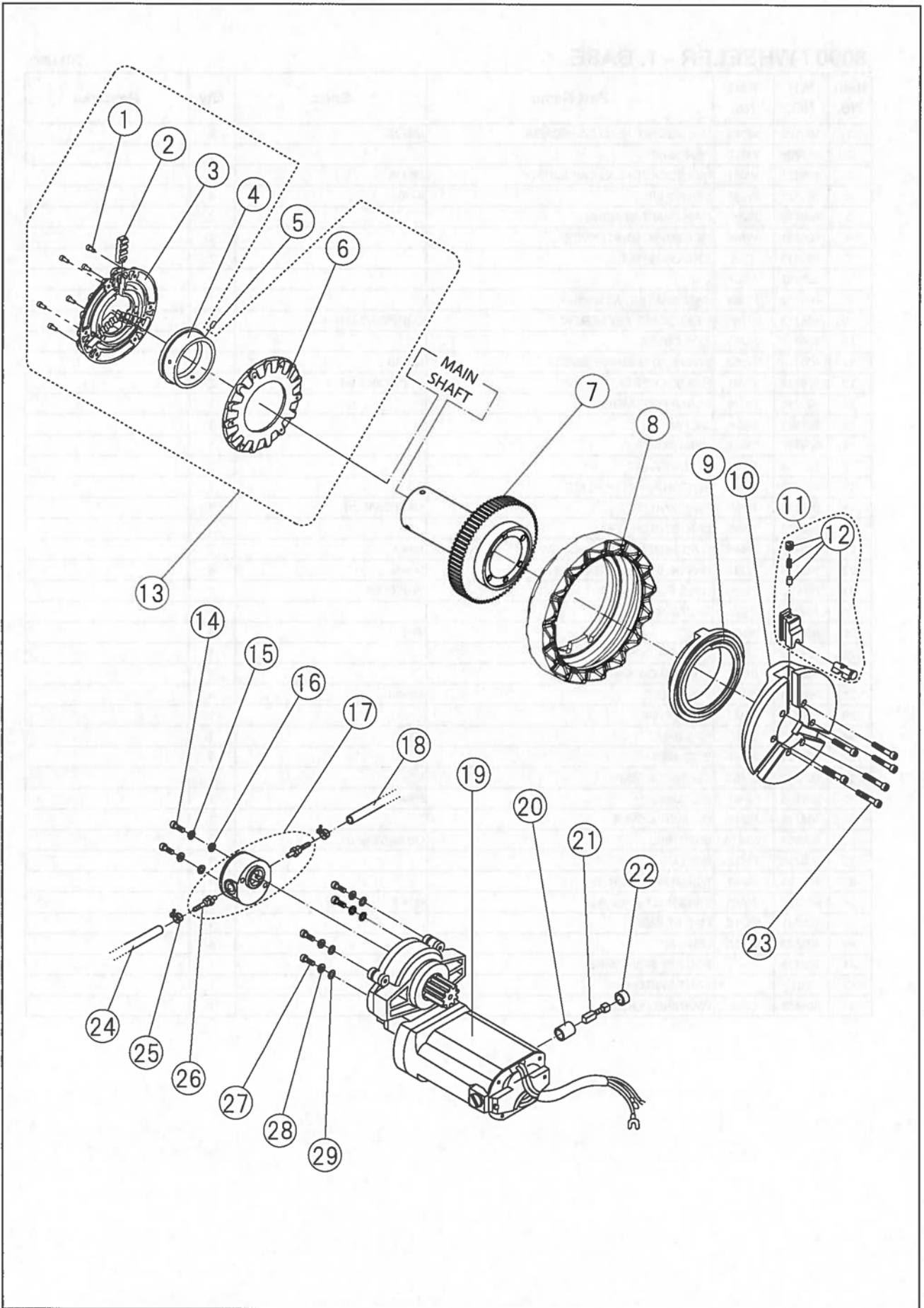

8090 / WHEELER - 2. MAIN SHAFT, MOTOR

2011/6/3

Item No.	WH NO.	Part No.	Part Name	Spec.	Qty	Remarks
1	606519	W053	HEX SOCKET HEAD CAP SCREW	M5×12	6	
2	609728	PM11	REAR CHUCK JAW	(3 PC. / SET)	1set	
3	609729	PM69	REAR CHUCK RECEPTACLE	R-type - BLACK	1	
4	609730	PM10	REAR SCROLL		1	
5	606163	WM62	ROLL PIN	6×12	3	
6	609731	PM68	REAR CHUCK COVER	R-type - BLACK	1	
7	609732	02NN0	MAIN SHAFT WITH GEAR		1set	
8	609733	PM70	HAND WHEEL	R-type - BLACK	1	
9	609734	NS00	FRONT SCROLL		1	
10	606473	NH00	CHUCK BODY		1	
11	606475	N0CJ	CHUCK JAW SET WITH NO.12	(3 PC. / SET)	1set	
12	60306	70KS	CHUCK JAW INSERT SET	S-type	1set	
13	609735	PM67	REAR CHUCK COMPLETE SET	R-type - BLACK	1set	
14	609736	W067	HEXAGONAL SOCKET HEAD CAP SCREW	M6×40	2	
15	275105	WG06	SPRING WASHER	M6	2	
16	600211	WI81	FLAT WASHER	M6	2	
17	609737	PM30	GEAR PUMP WITH JOINT		1	
18	609738	ZD12	OIL INTAKE LINE SUCTION TUBE	550mm	1	
19	609739	PM50	MOTOR	115V· 700W R/L	1	
20	609740	PMM16	CARBON BRUSH HOLDER		2	
21	609741	PMM10	CARBON BRUSH	(2 PC. / SET)	1set	
22	609742	PMM17	CARBON BRUSH CAP		2	
23	600476	#0024	HEX SOCKET HEAD CAP SCREW	M7×54	6	
24	609743	ZD11	OIL INTAKE LINE SUCTION TUBE	700mm	1	
25	600213	ZJ50	PIPE BAND	10mm	2	
26	601035	1035	JOINT		2	
27	609744	W08N	HEXAGONAL SOCKET HEAD CAP SCREW	M8×45	4	
28	600130	WG08	SPRING WASHER	M8	4	
29	600245	WI81	FLAT WASHER	M8	4	

8090 / WHEELER - 3. MOTOR ASSEMBLY

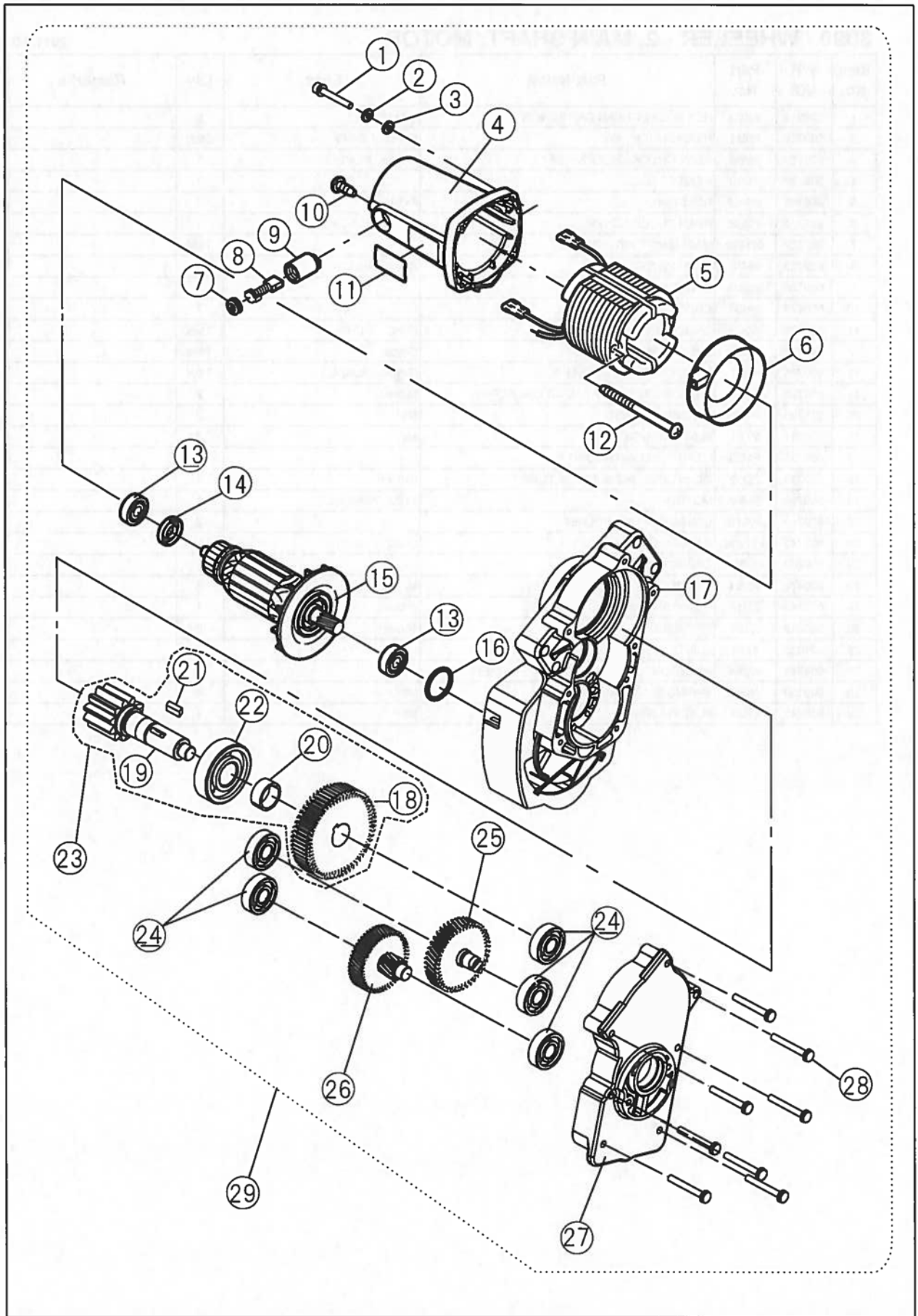

8090 / WHEELER - 3. MOTOR ASSEMBLY

2011/6/3

Item No.	WH NO.	Part No.	Part Name	Spec.	Qty	Remarks
1	609745	PMM61	HEX SOCKET HEAD CAP SCREW	M5×30	4	
2	609746	PMM62	SPRING WASHER	M5	4	
3	609747	PMM63	WASHER	5.3×10×1	4	
4	609748	PMM07	MOTOR CASE		1	
5	609749	PMM06	STATOR ASSEMBLY	115V	1	
6	609750	PMM09	FAN CASING		1	
7	609742	PMM17	CARBON BRUSH CAP	(2PCS. / SET)	1 set	see No.22 on 2. Main shaft
8	609741	PMM10	CARBON BRUSH	716SD (2 PCS/ SET)	1 set	see No.21 on 2. Main shaft
9	609740	PMM16	CARBON BRUSH HOLDER	(2PCS. / SET)	1 set	see No.20 on 2. Main shaft
10	609754	PMM55	TAPPING SCREW (B)	M4×14	2	
11	609755	PMMZ2	NAME PLATE	115V	1	
12	609756	PMM56	TAPPING SCREW (B)	M5×75	2	
13	609757	PMM31	BALL BEARING	#6200LLB	2	
14	609758	PMM32	DUST COLLAR		1	
15	609759	PMM02	ARMATURE	115V	1	
16	609760	PMM64	O-RING	S-32	1	
17	609761	PMM03	GEAR CASE		1	
18	609762	PMM11	FINAL GEAR		1	
19	609763	PMM12	FINAL PINION GEAR		1	
20	609764	PMM13	SPACER		1	
21	609765	PMM14	PARALLEL KEY	5×5×14	1	
22	609766	PMM15	BALL BEARING	#6304LLB	1	
23	609767	PMM1S	FINAL GEAR ASS'Y	NO.18-22	1 set	
24	609768	PMM60	BALL BEARING	#6201LLB	5	
25	609769	PMM2S	SECOND GEAR ASS'Y		1 set	
26	609770	PMM3S	FIRST GEAR ASS'Y		1 set	
27	609771	PMM04	GEAR COVER		1	
28	609772	PMM65	PHILLIPS PAN SCREW	M5×40	8	
29	609739	PM50	MOTOR		1	

8090 / WHEELER - 4. CARRIAGE

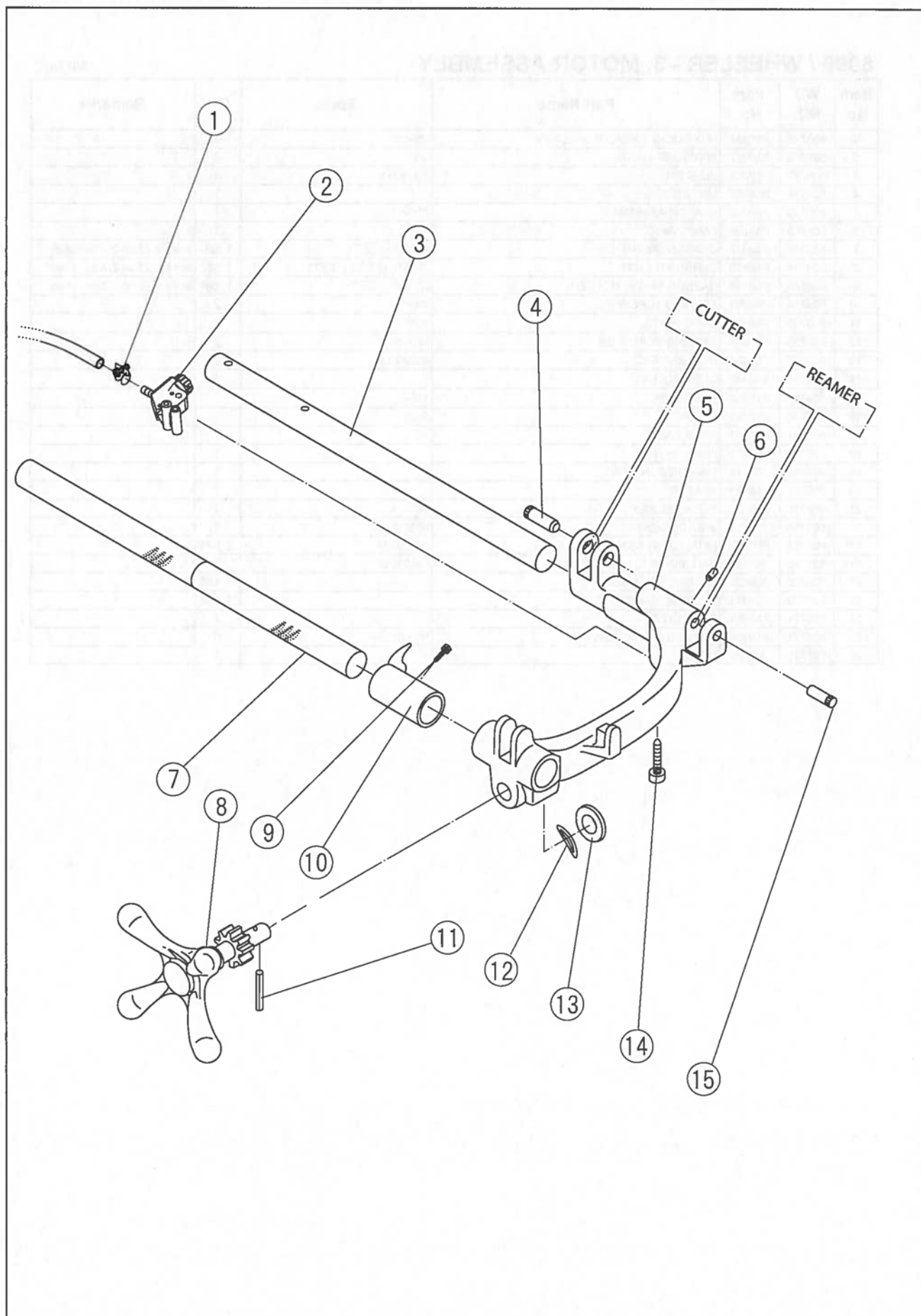

8090 WHEELER - 4 CUTTER REAMER

8090 / WHEELER - 4. CARRIAGE

2011/6/3

Item No.	WH NO.	Part No.	Part Name	Spec.	Qty	Remarks
1	600213	ZJ50	PIPE BAND	10mm	1	
2	609773	PM55	OIL TUBE CONNECTOR		1 set	
3	609774	PM04	CARRIAGE SUPPORT BAR B		1	
4	601076	1076	CUTTER ARM STOP PIN		1	
5	609775	PM89	CARRIAGE	R-type - BLACK	1	
6	606488	G861	STOPPER	Φ10	1	
7	609776	PM03	CARRIAGE SUPPORT BAR A		1	
8	609777	PM41	CARRIAGE HANDLE	WITH FEED GEAR SHAFT	1	
9	600329	PN38	SECURITY COLLAR SCREW	M5×8	1	
10	606489	N081	SECURITY COLLAR	R-type - BLACK	1	
11	600666	WL54	SPRING PIN	8×35	1	
12	606304	WH18	WAVE WASHER	18	1	
13	609778	WI87C	FLAT WASHER	28×17×3	1	
14	600167	W06B	HEXAGONAL SOCKET HEAD CAP SCREW	M6×25	1	
15	609045	1096	REAMER HOLDER STOP PIN		1	



8090 / WHEELER - 5. CUTTER, REAMER

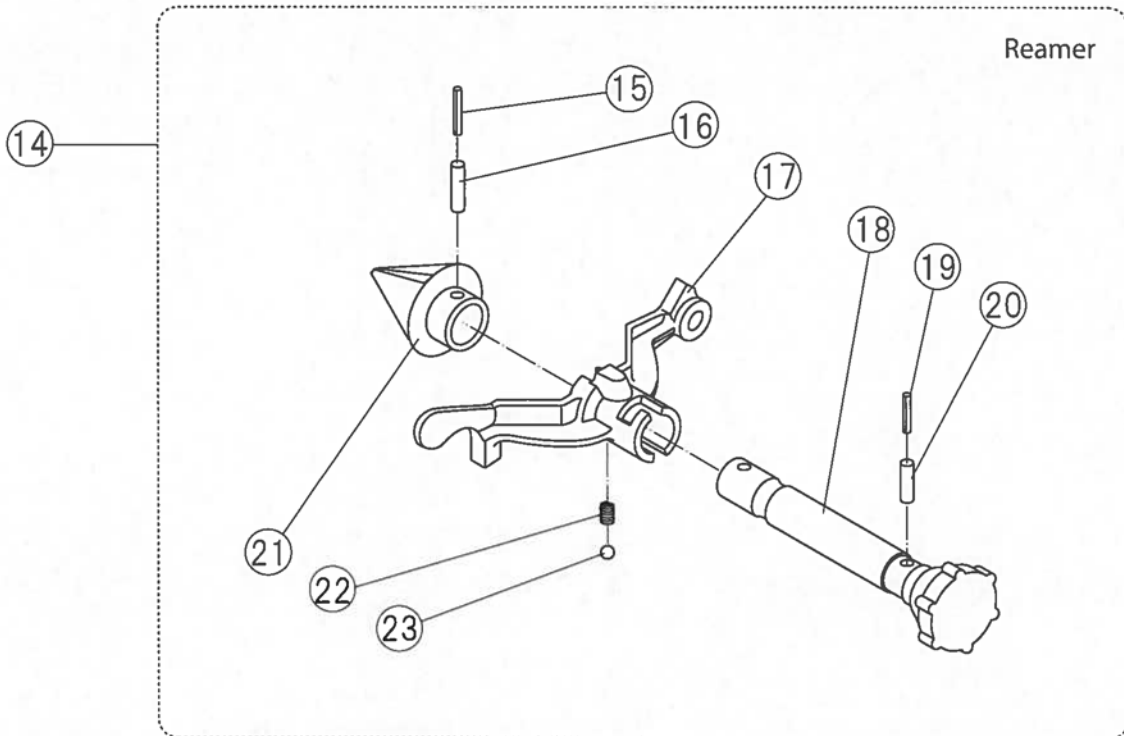
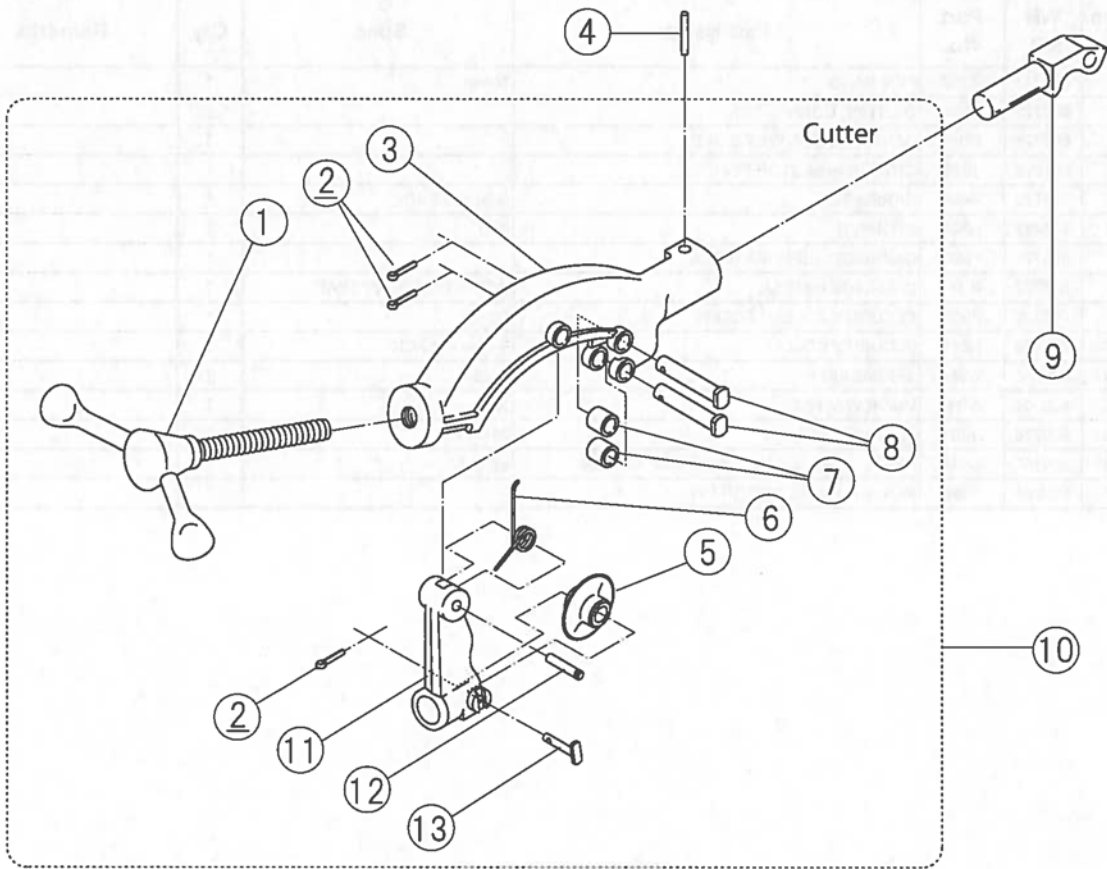

8090 / WHEELER - 5. CUTTER, REAMER

2011/6/3

Item No.	WH NO.	Part No.	Part Name	Spec.	Qty	Remarks
1	609779	PM43	CUTTER HANDLE WITH FEED SCREW		1	
2	600171	WN12	SPLIT PIN	#2.3×15	3	
3	606509	N602	CUTTER FRAME	R-type - BLACK	1	
4	604072	4072	CUTTER FRAME STOP PIN	SHORT	1	
5	60324	5076	CUTTER WHEEL		1	
6	609025	9025	SPRING		1	
7	605074	5074	CUTTER ROLLER		2	
8	605079	5079	CUTTER PIN	LONG	2	
9	600802	N608	CUTTER ARM	R-type - BLACK	1	
10	609781	ONCTRS	CUTTER COMPLETE SET	R-type - BLACK	1 set	
11	609782	4067	CUTTER GUIDE		1	
12	609027	9027	CUTTER GUIDE PIN		1	
13	602471	2471	CUTTER PIN	SHORT	1	
14	609783	ONRTRS	REAMER COMPLETE SET	R-type - BLACK	1 set	
15	609784	WLA2	ROLL PIN	4.75×45	1	
16	600482	WL87	ROLL PIN	8×45	1	
17	606513	N605	REAMER HOLDER	R-type - BLACK	1	
18	600808	N027	REAMER SHAFT (WITH HAND GRIP)		1 set	
19	600658	WLA1	ROLL PIN	4.75×35	1	
20	600666	WL86	ROLL PIN	8×35	1	
21	609786	PM38	REAMER CONE		1	
22	600224	5096	SPRING	8×10	1	
23	600168	WQ08	STEEL BALL	8	1	

8090 / WHEELER - 6. NV-type Die Head 1/2 - 2

292802 (R) : 1/2-2 NPT

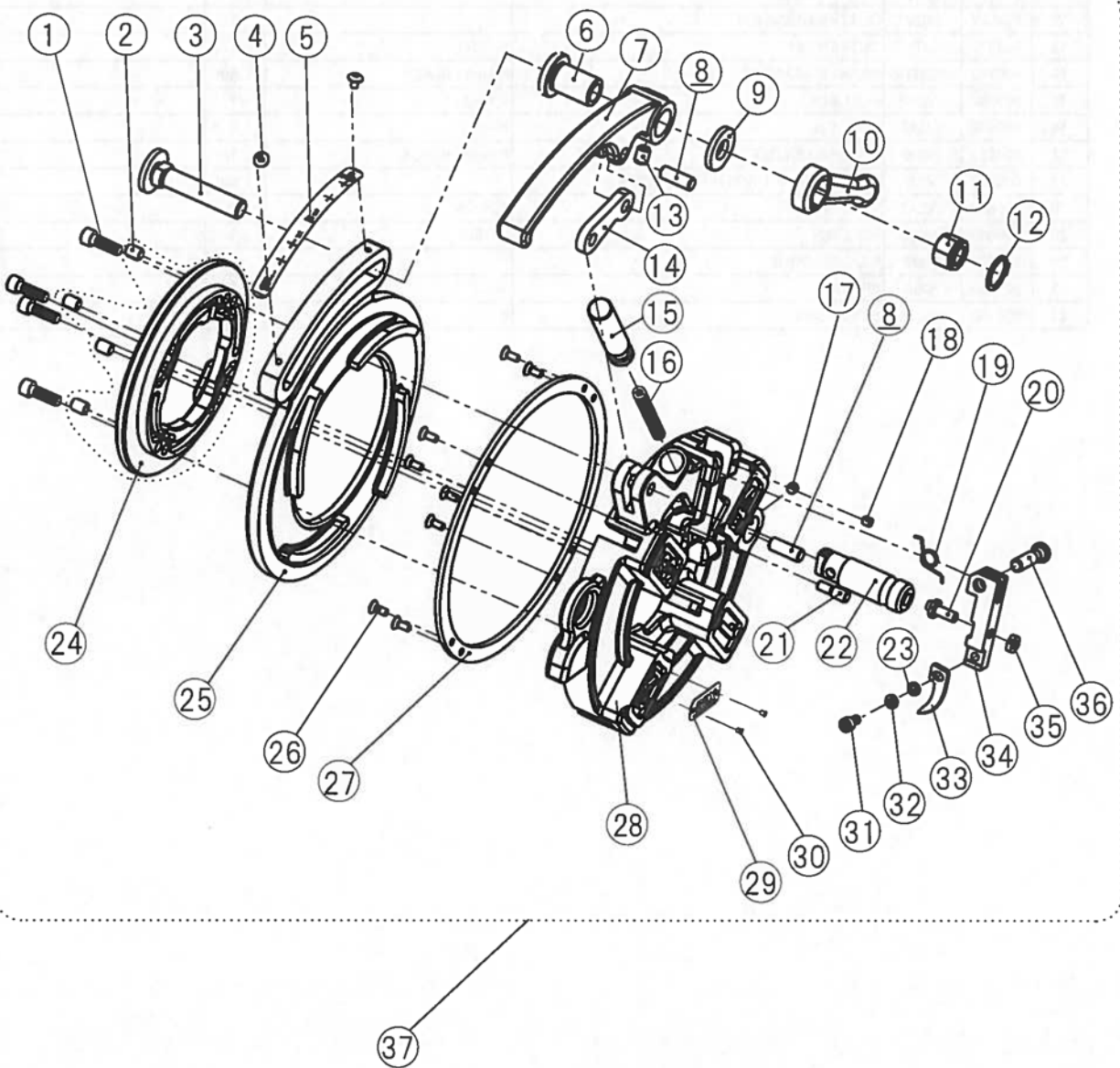

8090 / WHEELER - 6. NV-TYPE DIE HEAD 1/2 - 2

2011/6/3

Item No.	WH NO.	Part No.	Part Name	Spec.	Qty	Remarks
1	600486	W063	HEX SOCKET HEAD CAP SCREW	M6×20	4	
2	609787	G860	DIES NOTCH	Option	4	
3	609788	NR76	CAM PLATE FIXING PIN		1	
4	609789	W240	CROSS RECESS PAN HEAD SCREW	M4× 5	2	
5	609790	NR86	SIZE PLATE (R-type)		1	
6	609791	NR77	BUSH		1	
7	609792	NR72	OPEN LEVER A (R-type)		1	
8	609793	NR93	HINGE PIN		2	
9	609794	NR80	WASHER		1	
10	609795	NR73	LEVER NUT		1	
11	609796	NR79	NUT		1	
12	609797	WW19C	SNAP RING 19 (Outside Φ17.5)	T=1.2	1	
13	609798	NR87	SHOCK ABSORPTION URETHANE	Φ8×10	1	
14	609799	NR75	OPEN LEVER LINK		1	
15	609800	NR78	AUTO-OPEN PLUNGER		1	
16	609801	NR83	SPRING		1	
17	609802	W661	HEX SOCKET SET SCREW	Truncated cone point M6× 6	1	
18	609803	N752	HEX SOCKET SET SCREW	Truncated cone point M5× 6	1	
19	609804	NR88	SETTING SPRING		1	
20	609805	NR89	AUTO-OPEN ECCENTRIC PIN		1	
21	609806	NR82	GUIDE PIN		1	
22	606522	N676	DIE-HEAD POST (R-type)		1	
23	609808	W161	WASHER	6×13×1	1	
24	609809	N679	RETAINING RING		1	
25	609810	NR71	CAM PLATE (R-type)		1	
26	609811	W34A	HEX SOCKET FLAT HEAD MACHINE SCREW	M4×10	8	
27	609812	N728C	DIE-HEAD RING		1	
28	609813	NR70	DIE-HEAD BODY (R-type)	With die head post (N676 or NR57) & Hinged pin (NR93)	1	
29	609814	7830	REX LOGO PLATE		1	
30	600621	WN34	RIVET	4×5	2	
31	600438	N061	HEX SOCKET HEAD CAP SCREW	M6×12	1	
32	600132	WG06	SPRING WASHER	6	1	
33	609815	NR81	AUTO-OPEN LEVER B	NPT	1	
34	609816	NR90	AUTO-OPEN LEVER A		1	
35	600177	WD06	HEXAGON NUT	M6	1	
36	609817	NR91	LEVER PIN		1	
37	80118	292802	1/2-2 DIE HEAD		1	

