

Rhino Tool Company, Inc.

P.O. Box 111
Kewanee, IL 61443

Please visit:
www.rhinotool.com to find your nearest
servicing Rhino Dealer

300814



Rhino® Multi-Pro™ Service Kit Installation

Rhino® Multi-Pro™ Standard Configuration

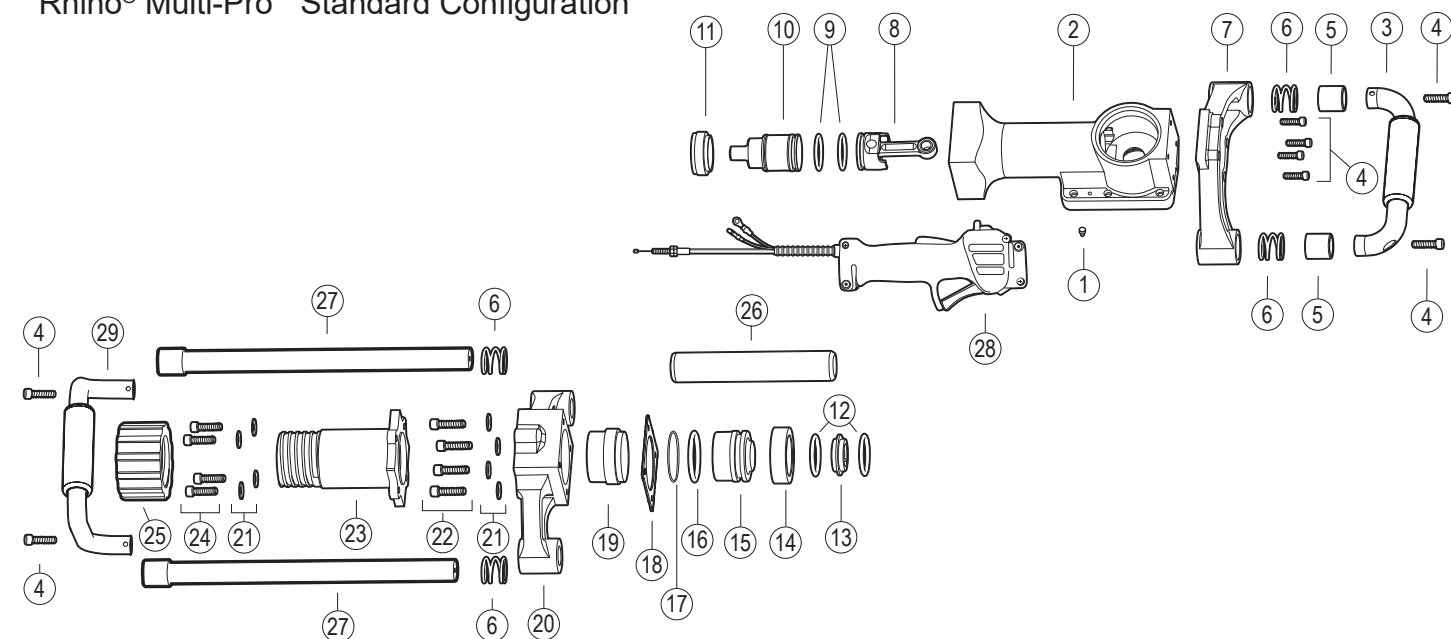

1: Remove the Chuck-Lok Locking Nut (#25) from the Master Chuck (#23)

2: Remove the four 1/4" bolts (#24) and Washers (#21) from the Master Chuck (#23). Set the Master Chuck and Chuck-Lok Locking Nut aside.

3: Loosen the two 5/32" bolts on the Throttle (#28). Do Not Remove Them.

4: Mark the top side of the Handle Collars (#5) with a black marker or alike as they are specific on the direction they are installed. Using a 1/4" Hex Wrench, remove the two 5/16" bolts (#4) recessed in the Top Handle Assembly (#3). **Caution as the Handle Collars (#5) are under tension from the Handle Springs (#6).** Set aside.

5: Using a 1/4" Hex Wrench, remove the four 5/16" bolts (#22) and washers (#21) from the lower body (#20). Take down the Lower Body with both Side Handle (#27) and Lower Handle Assembly (#29) attached. Remove the Throttle (#28) from the Side Handle.

6: Discard the used O-Ring (#17) and Gasket (#18). Clean the remaining gasket adhesive from the Lower Body (#20) and Body Assembly (#2).

7: Extract the Anvil O-ring Cup (#14) and its components; Large Retainer (#13) and Large Retainer O-rings (#12) from the Lower Body (#20). Inspect for damage.

8: Remove the Anvil (#15) from the Sleeve (#19) in the Lower Body (#20). Inspect the Sleeve for damage. Remove the Anvil O-ring (#16) and discard. Lubricate the Anvil's O-ring groove with the lubricant supplied with the kit and install the new Anvil O-ring, reseal the Anvil into the Sleeve.



Rhino® Multi-Pro™ Service Kit Installation

Rhino® Multi-Pro™ Lower Body and Crankcase Configuration

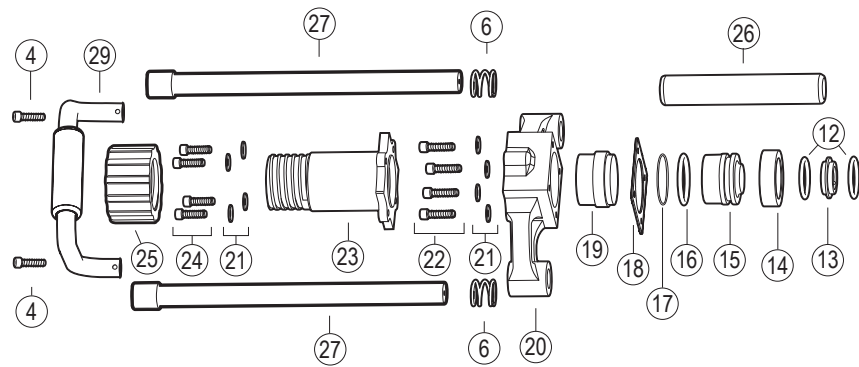

9: Take the components out from the Anvil O-ring Cup (#14) and inspect all for damage. Replace the used Large Retainer O-rings (#12) with new ones from the kit. Lube all components. Make sure that the Large Retainer (#13) is positioned correctly, as shown, incorrect installation can result in damage to the driver. Re-install the Anvil O-ring Cup with components into the sleeve. Remove the backing from one side of the Gasket (#18) and place that side on the Lower Body (#20) leaving the other side covered to be installed later.

10: Install the Anvil O-ring Retainer (#11) on top of the Anvil O-ring Cup and its components. The Anvil O-ring Retainer only installs one way, installing it wrong may result in damage to the driver. Set the Lower Body (#20) and all parts attached to the side and focus on the Body Assembly (#2)

11: Remove the Crankcase Cover (#44) and discard Crankcase Cover O-ring (#45). Lube and install the new Crankcase Cover O-ring from the kit. Set aside.

12: With a black marker, or alike, mark the Piston Assembly (#8) to re-install it in the same orientation when reassembling. Note that the Crank Pin (#46) is left hand thread. Use a 7/8 deep-well socket to remove the Crank Pin. Inspect the Crank Pin and threads for damage as well as the Crank Shaft (#48) threads. Extract the Piston Assembly and Hammer (#10) from the Body Assembly (#2) and remove the O-rings and discard. Inspect the Self Lubricating Bronze Sleeve Bearing in the Connecting Rod of the Piston Assembly and check either for wear or out of roundness. Piston Assembly is only available as a complete assembly.

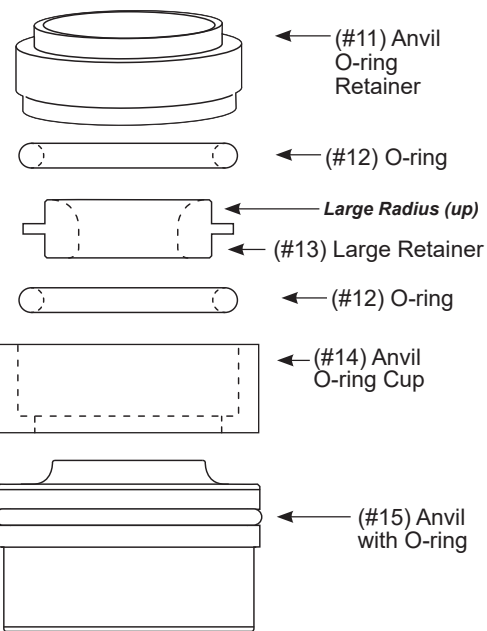
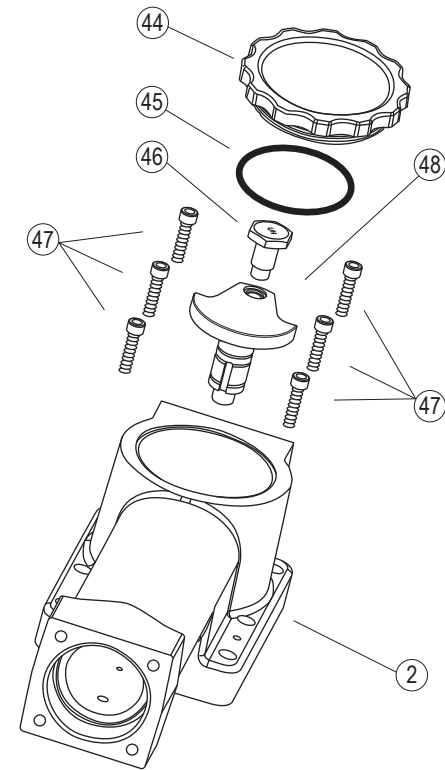

Insert O-ring into Anvil O-ring Cup, then insert Large Retainer (with large radius up), then insert other O-ring.



Rhino® Multi-Pro™ Service Kit Installation

Lube the Hammer and Piston Assembly O-ring groove and install one of the Piston/Hammer O-rings (#9) from the kit on each. Set aside.

13: Clean all lubricant from the Crank Pin (#46) and lay on a shop towel along with the four Chuck Bolts (#24) with Washers (#21) installed, four Lower Body Bolts (#22) with Washers installed, and two Handle Bolts (#4). Including the Crankshaft (#48) and Side Handle Assembly's (#27) spray all threads with Loctite N 7649 Primer and let dry. **Check all washers as they are the two piece design shown at right.**

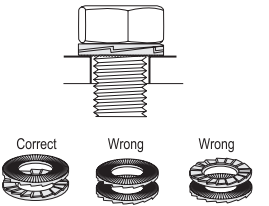

14: Clean out all lubricant from the Body Assembly (#2). Install Piston Assembly (#8) with the connecting rod facing the top of the driver and mark made in Step 12 facing outward. Locate the Self Lubricating Bronze Sleeve Bearing in the Connecting Rod of the Piston Assembly and align it with the threads in the Crank Shaft (#48). Apply Loctite 243 Threadlocker to the Crank Pin Threads and install it through the connecting rod of the piston assembly. Crank Pin has left hand threads. Torque to 360 in/lbs. Install Hammer (#10) with the Hammer O-ring (#9) towards the top of the driver.

15: Obtain the Lower Handle/Body Assembly from Step 9. Remove the backing from the exposed side of the Gasket (#18). Place the Sleeve O-ring (#17) on top of the gasket. Apply Loctite 243 Threadlocker to the four Lower Body Bolts (#22). Install the Throttle (#28) on the Side Handle Assembly (#27). Install the Lower Handle/Body Assembly on the Body Assembly (#2) and torque to 251 in/lbs. Place the top of both side handle assemblies (#27) through the top handle bracket (#7) and slide the throttle to its lowest point and tighten the upper 5/32" HEX bolt used to hold the Handles in their most up position. Make sure the handle springs (#6) are installed in the top handle bracket.

16: Install the handle collars (#5) with the mark made in Step 4 in the up position. Insert both handle bolts (#4) into the Top Handle Assembly (#3) so that the threads are exposed. Apply Loctite 243 Threadlocker to the bolt threads and install the Top Handle Assembly on to the Handle Collars. Apply downward force to compress the Handle Springs (#6) and torque the Handle Bolts to 132in/lbs.

17: Loosen the 5/32" HEX Bolt on the Throttle, move it to the final position and hand tighten the 5/32" HEX Bolts. Apply Loctite 243 Threadlocker to Chuck Bolts (#24). Position the Master Chuck (#23) up to the Lower Body (#20) and install Chuck Bolts. Torque to 251in/lbs.

18: Hand tighten the Chuck-Lok Locking Nut (#25) onto the Master Chuck (#23). Fill the crankcase with one tub of lubricant from the kit. With a 7/8" Deep-well Socket spin the Crank Pin (#46) counter-clockwise feeling for any binding on the Piston Assembly (#8). Locate Crankcase Cover (#44) with Crankcase Cover O-ring (#45) from Step 11 and install. **Hand tighten only.**



Multi-Pro Service Kit Part No. 301509:
 (#9) O-Ring Seal for Piston and Hammer (2)
 (#45) O-Ring Seal for Pro-Series Crankcase Cover
 (#12) Large Retainer O-Ring Seal (2)
 (#16) Multi-Pro Anvil O-Ring Seal
 (#17) Chuck Tube or Sleeve O-Ring Seal
 (#18) Multi-Pro Body Gasket
 Rhino Pro-Series Lubricant (2)