

OWNER'S MANUAL
WET TILE RAIL SAW 10"
Model: CTR1042L



Scan for a
Digital copy of the
Owner's Manual

CAUTION: Read all safety and operating instructions before using this equipment.
This manual **MUST** accompany the equipment at all times.

REDEFINING
JOBSITE MUSCLE™

CTR1042L saws manufactured by Norton Clipper are warranted against defects in workmanship or materials for a period of one (1) year from the original purchase date from Norton Clipper when used in commercial, institutional, rental, or professional use.

To activate your warranty for all Norton Clipper products visit the **Product Registration** page on the website and register your machine.

The responsibility of Norton Clipper under this warranty is limited to replacement or repair of defective parts at a point designated by it, of such part as shall appear to us upon inspection at such point, to have been defective in material or workmanship, with expense for transportation borne by the customer.

In no event shall Norton Clipper be liable for consequential or incidental damages arising out of the failure of any product to operate properly.

Integral units such as **gasoline engines, electric motors, batteries, tires, transmissions, etc.**, are excluded from this warranty and are subject to the prime manufacturer's warranty. This warranty is in lieu of all other warranties, expressed or implied, and all such other warranties are hereby disclaimed.

Important: Before placing equipment in operation, record the following information:

UPC #: <i>(starts with 701846-xxxxx)</i>	MODEL #:
<input type="text"/>	<input type="text"/>
SERIAL #:	PURCHASE DATE:
<input type="text"/>	<input type="text"/>
PURCHASED FROM:	ADDRESS/CITY/STATE/ZIP:
<input type="text"/>	<input type="text"/>

Before using this equipment, make sure that the person using it has read and understands the instructions in this Owner's Manual.









**PRODUCT
 REGISTRATION**
 Scan To
 Activate Your
 Warranty

Table of Contents	1
Safety Precautions	4-8
Dust and Silica Warning	6
Machine Lifting Points	8
SPECIFICATIONS & Features	9-11
CTC102XL Specifications	9
Optional Accessories	11
Unpacking, Assembly, & Setup	12-25
Components and Orientation of the CTR1042L	13-14
Folding Legs	14-15
Attaching and Using the Accessories	15-22
Transport Wheels	15-17
Transport Handles	17
Side Table Extension	18
Power Cable and Water Hose Support	18-19
Water Pump and Overflow Drain Plug	19-21
Water Pump Installation	19-20
Overflow Drain Plug	20-21
Adjustable Angle Guide	21-22
Blade Installation	22
Cutting Depth	23-25
Cutting at a Constant Depth	23
Plunge Cuts	24
Miter Cuts	24-25
Electrical	26-
Electrical Specifications	26
Extension Cords	26

Electrical Supply	26
Wiring Diagram	38
General Electrical Troubleshooting	28-29
Operation.....	30
Wet Cutting Do's & Don'ts	30
Dry Cutting Do's & Don'ts	30
Saw Maintenance & Troubleshooting.....	31-32
Parts Breakdown.....	33-37
Parts Ordering	33
Main Assembly Group	34-35
Cutting Head Group.....	36-37







Important warnings and pieces of advice are indicated on the machine with icons.

HAZARD ICONS

	<p>Hot surface! Do not touch. Engine components can get extremely hot from operation. To prevent burns, do not touch the engine or related parts while the engine is running or immediately after it is turned off. Never operate the engine with any heat shields or guards removed.</p>
	<p>Keep all guards in place when operating any piece of equipment.</p>
	<p>Moving parts can crush and cut. Keep hands, feet, hair, and loose clothing away from all rotating parts.</p>
	<p>Lethal Exhaust Gas: use only in well ventilated areas. Engine exhaust gases contain poisonous carbon monoxide, which is odorless, colorless, and can cause death if inhaled. Avoid inhaling exhaust fumes, and never run the engine in a closed building or confined area.</p>
	<p>Never tamper with the governor components of settings to increase the maximum speed. Severe personal injury and damage to the engine or equipment can result if operated at speed above maximum. Always obey the maximum speed rating of blade.</p>
	<p>Warning alert symbol. DO NOT LIFT THE SAW BY THE HANDLEBARS OR CUTTING TABLE.</p>

Important warnings and pieces of advice are indicated on the machine with icons.

SAFETY ICONS

 <p>Read operator's instructions.</p>	 <p>Read OSHA and ANSI B7.1. Visit the industry safety page: www.safety.UAMA.org</p>
 <p>Eye protection must be worn.</p>	 <p>Ear protection must be worn.</p>
 <p>Protect your lungs against dust.</p>	 <p>Hand protection must be worn.</p>
 <p>Rotation direction of the blade.</p>	 <p>Pump On Pump Off</p>

DUST AND SILICA WARNING

Grinding/cutting/drilling of masonry, concrete, metal, and other materials can generate dust, mists and fumes containing chemicals known to cause serious or fatal injury or illness, such as respiratory disease, cancer, birth defects or other reproductive harm. If you are unfamiliar with the risks associated with the particular process and/or material being cut or the composition of the tool being used, review the material safety data sheet and/or consult your employer, the material manufacturer/supplier, governmental agencies such as OSHA and NIOSH and other sources on hazardous materials and make certain to comply with all product warnings and instructions for the safe and effective use of the material being cut. California and some other authorities, for instance, have published lists of substances known to cause cancer, reproductive toxicity, or other harmful effects.

Control dust, mist, and fumes at the source where possible. In this regard use good work practices and follow the recommendations of the manufacturer/supplier, OSHA/NIOSH, and occupational and trade associations. Water should be used for dust suppression when wet cutting is feasible. When the hazards from inhalation of dust, mists and fumes cannot be eliminated through engineering controls such as vacuum and/or water mist, the operator and any bystanders should always wear a respirator approved by NIOSH/MSHA for the material being cut.

CALIFORNIA PROPOSITION 65 MESSAGE

Some dust created by power sanding, sawing, grinding, drilling, and other construction activities contain chemicals known (to the State of California) to cause cancer, birth defects or other reproductive harm. Some examples of these chemicals are:

- Lead, from lead-based paints
- Crystalline silica, from bricks and cement and other masonry products
- Arsenic and chromium, from chemically treated lumber

For Addition Information Consult the Following Sources:

<http://www.osha.gov/dsg/topics/silicacrystalline/index.html>

<http://www.cdc.gov/niosh/consilic.html>

<http://oehha.ca.gov/prop65/law/P65law72003.html>

<http://www.dir.ca.gov/Title8/sub4.html>

Use Approved:



Eye Protection



Hearing Protection



**Respiratory
Protection**



Head Protection



The engine exhaust from this product contains chemicals known to the State of California to cause cancer, birth defects or other reproductive harm

108934

1. Before mounting any blade on the saw, the blade should be inspected for any damage which might have occurred during shipment, handling, or previous use.
2. The blade collars and arbors should be cleaned and examined for damage before mounting the blade.
3. The blade must be properly fitted over the arbor with the relief side of the collars facing the blade.
4. The blade shaft nut must be tightened securely against the outside blade shaft collar.
5. The blade must be operated within the specified maximum operating speed listed on the blade.
6. Fill the water pan with water.
7. The blade guard must be in place with the nose guard down and locked when the saw is running.
8. The operator should wear safety glasses and any other appropriate safety equipment.
9. When starting the saw, the operator should stand away and to the side of the blade.
10. If for any reason the saw should stall in the cut, remove the material from the blade. Check the outside blade shaft collar and nut for tightness. Inspect the blade for damage before restarting the saw. Use caution when resuming a cut. Be certain that the blade is in alignment with the previous cut.
11. Do not force the blade into the cut by pushing the material into the blade too fast.



You Are Responsible For Your Safety!!!

Lifting Points

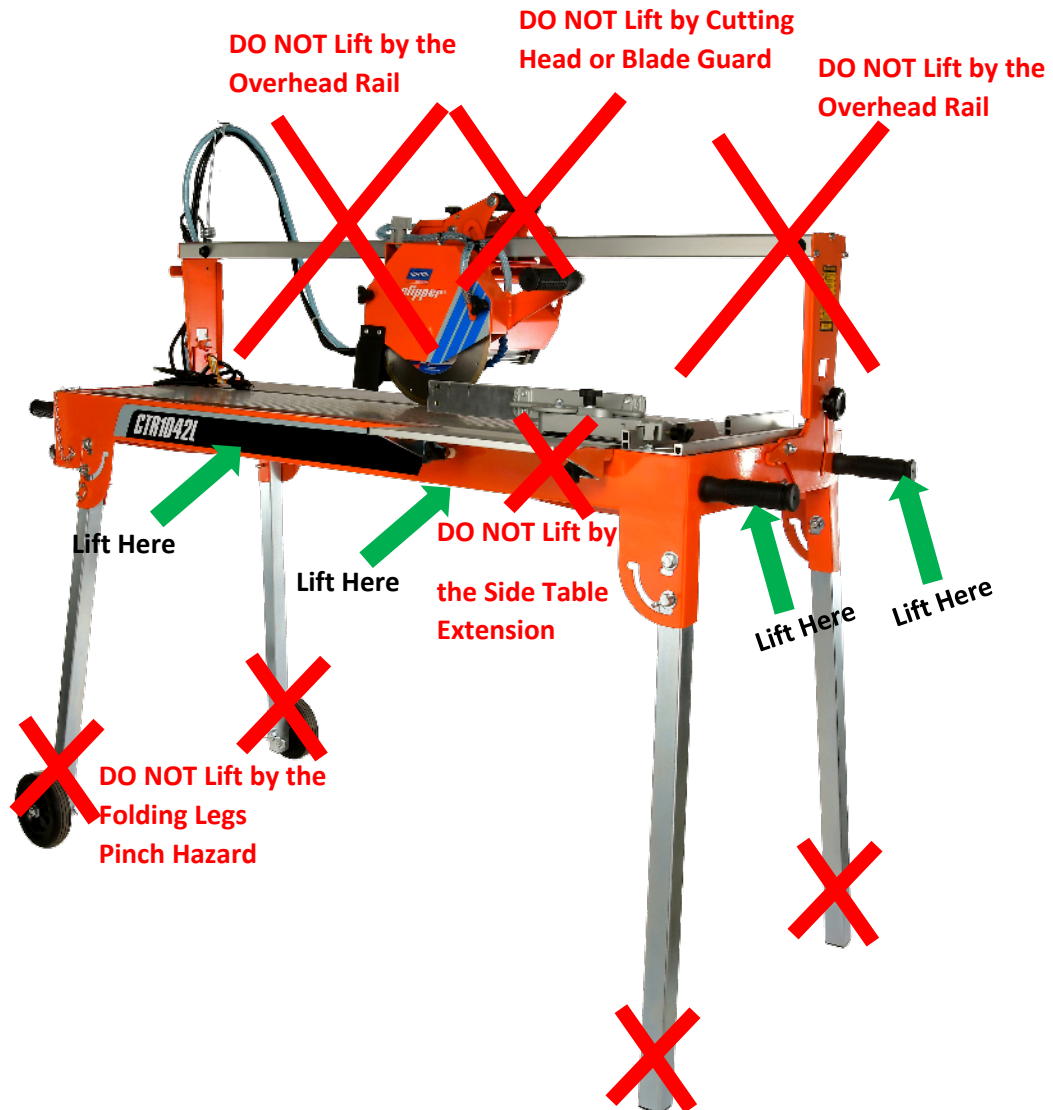

CTR1042L Lift Points

- The best lifting point is from the screw in handles located on the front and rear of the CTR1042L or the underside of the water pan which is highlighted with **GREEN** arrows on both sides of the machine or at the front and back.
- DO NOT lift by the Overhead Rail
- DO NOT lift by the Cutting Table
- DO NOT lift by the Cutting Head or Side Extension Table
- DO NOT lift by the Blade Guard
- DO NOT lift by the Folding Legs
- DO NOT move or lift by pulling on the Power Cord.
- Always verify that the power is disconnected from the CTR1042L before moving or lifting.

1. A Powerful 1.5 HP Induction Motor for long life and the maximum cutting power.
2. The Automatic Thermal Overload Protection system protects your saw from power surges and overheating.
3. The all-steel water tray withstands even the toughest jobs and provides the longest life.
4. The saw is encased in a sturdy, durable steel frame, optional equipped with folding stands with work bench for easier operation.
5. Plunge cut capacity allows rip cutting of 48" long materials with more compact length machine.
6. The cutting alignment will not be affected by any water tray maintenance.
7. Miter cut capable.
8. The cutting table can be secured in place by tightening the knob screw on the L-shaped transport retention plate.
9. The adjustable cutting rip guide is designed for both 90° square cutting and any angle between 0 to 90°.
10. The CTR1042L blade capacity is 10" and can be used with 8" which provides a variety of blade usage.
11. Rip cuts materials up to 48" long or diagonal cuts 30" materials.
12. Designed for Tile, Stone, and larger materials up to 2.4" thick



CTR1042L	
Maximum Cutting Length (mm)	48" (1,220) w/plunge cut – 42" (1,067) without plunge cut
Maximum Diagonal Cutting (mm)	30" (762)
Max Blade Size (mm)	10" (254)
Max. Depth of Cut (mm)	2.4" (61)
Max Depth of Cut @ 45°	2.4" (61)
Blade RPM	3,240 RPM
Horsepower	1.5 HP (1.1 kW)
Motor Engine Type	Induction
Electrical (Volts/Cycles/Phase)	115v/60Hz/1
Dimensions (mm)	62-3/4" x 25-3/8" x 30" (1,594 x 645 x 762 mm) w/Legs Extended
Cart Table size (mm)	14-1/4" (362) L x 15" (381) W
Pan Size (mm)	51-7/8" (1,318) x 25-3/16" (640)
Weight (Kg.)	164 lbs. (74.5)

CTR1042L Specifications



Cutting Depth Control
The cutting depth can be adjusted easily from the side of the head.

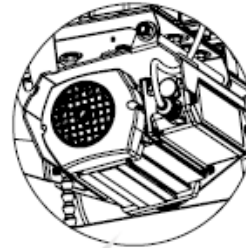

Powerful 1-1/2 HP Motor
Direct drive induction motor mounted under the cutting head to maintain a small form factor while still able to cut large format material.

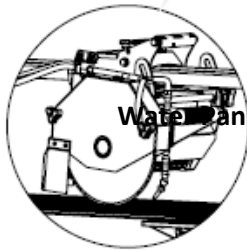

Blade Guard
Blade guard can be completely removed for easy access to blade.

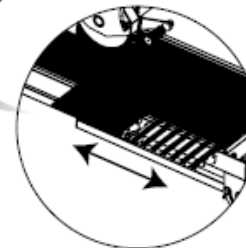

Side Extension Table
Solid aluminum and steel construction that can be positioned anywhere along the frame of the saw.

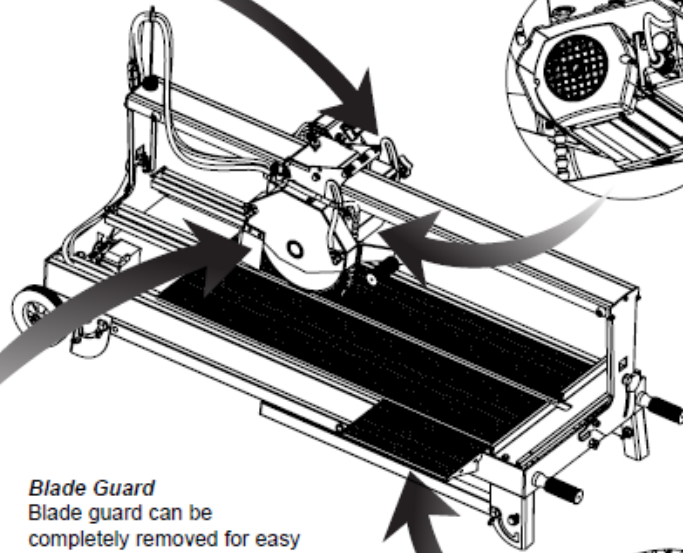

CTR1042L Features





UPC	Description
Powerful Motor	Low profile 1.5 HP (1.1 kW) 115v/60Hz/1 phase motor provides long life and is powerful enough to cut any material
Side Extension Table	Made of durable steel and aluminum to provide additional surface for when cutting along the width of longer materials
Blade Guard	All steel blade guard with water feed sides can be removed for easy unimpeded access to the blade
Cutting Depth Control	Adjustable cutting depth allows the usage of 10" or 8" and setting the required dept of cut in addition the CTR1042L features a plunge cut feature which allows cutting of longer 48" (1,220) materials with a machine with the same length as a 42" (1,067)
Water Pan	All steel construction with integrated water pump compartment
Cutting Table	Provides full length support of materials up to 48" (1,220) and is secured in place with screws to prevent lost and to reduce damage
Folding Legs	Built in folding leg stand can be deployed by a single person
Transport Wheels	The transport wheels feature toolless installation and can be placed on the frame or on the folding leg stand
Vertical Storage	The CTR1042L can be stored vertical for reduced warehouse space

Items Includes with the CTR1042L



The CTR1042L ships fully assembled and only the accessories and blade will be needed to prepare the machine for usage.

- Water Pump
- Accessory Bag
- Transport Handle (4)
- Transport Wheel Kit
- Adjustable Angle Guide (aka Adjustable Guide-A-Cut)
- Universal Wrench
- Side Table Extension with Hardware
- Genuine Norton Clipper Continuous Diamond Blade for tile

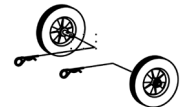
Optional Accessories

UPC	Description	QTY	Type	Image
70184634080	Adjustable Angle Guide w/Hardware	1	S	
70184680905	Wrench Universal	1	S	
70184634087	Side Table Extension CTR1042L	1	S	
70184634084	TRANSPORT Handles Set of Four (4)	1	S	
70184634082	Transport Wheels w/Hardware Set of Two (2)	1	S	

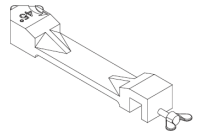
Optional Accessories:

UPC	Description	QTY	Type	Image
70184682710	RIP Guide 45/90°	OPT	S	
70184633009	GFCI plug NEMA 5-15P x NEMA 5-15R (Connect to Power Supply then attach machine or extension cord to GFCI for additional operator protection)	OPT	S	



Open the container, carefully lift the saw by the saw from the packaging and place it on a flat, level working area. Be certain that you have the following items before you discard the container.

- Saw
- Water Pump
- Accessory Bag
- Transport Handle (4)
- Transport Wheels
- Universal Wrench
- Side Table Extension
- Genuine Norton Clipper Ø10" Continuous Rim Tile Saw Blade
- Owner's Manual

Components and Orientation of the CTR1042L

Use the following image for familiarization of the CTR1042L main components and orientation:

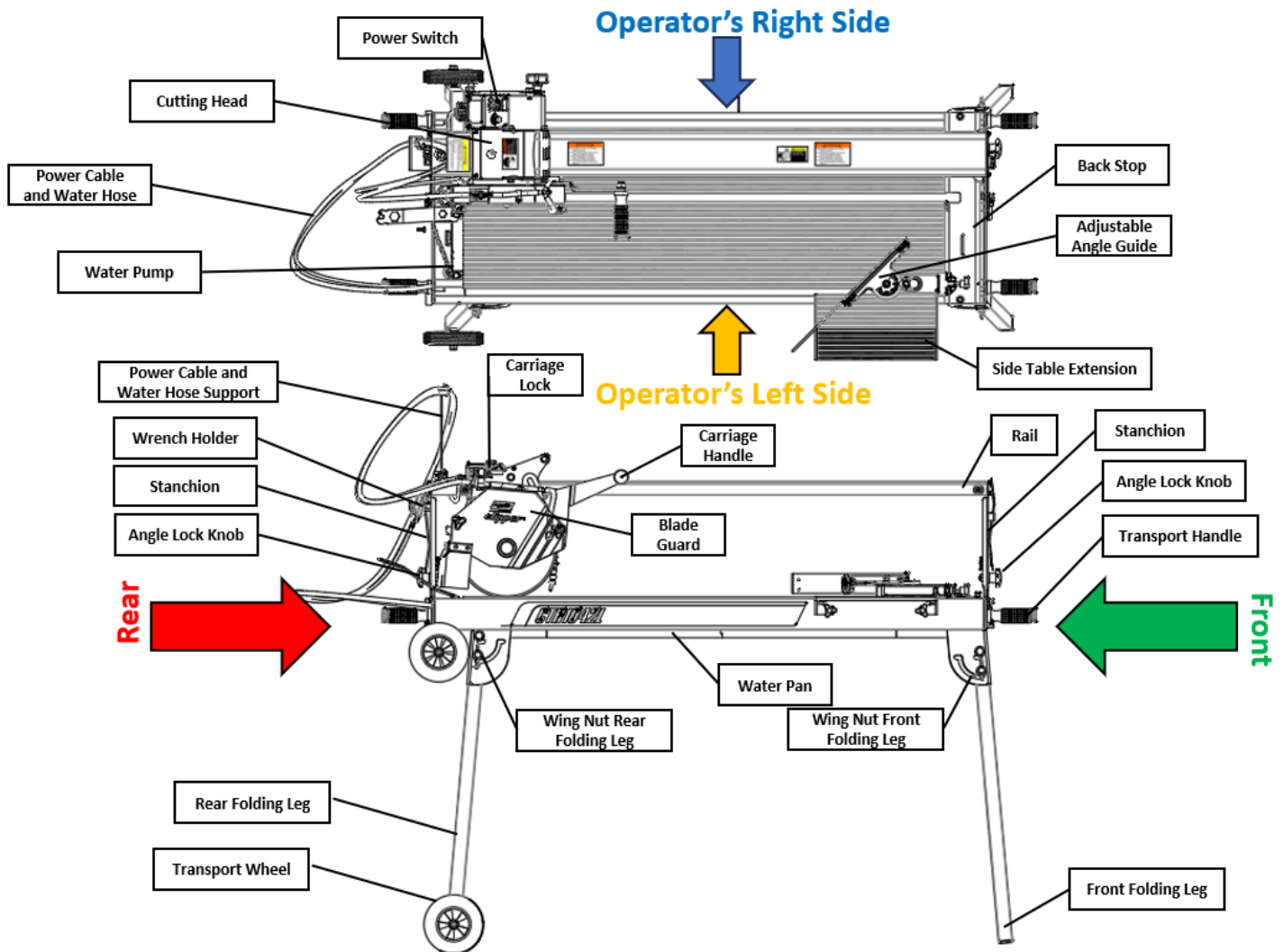

CTR1042L Components and Orientation

NOTE: CTR1042L shown with Legs Deployed and an Extra Set of Transport Wheels. The CTR1042L only ships with one (1) set of Transport Wheels.

Deploying the Legs

The CTR1042L can be used with the Legs deployed (open position) or from the closed position. The following instructions describe how to deploy (open) the legs.



WARNING: The Folding Legs Create a Finger Pinch Hazard



Folding Legs:

The CTR1042L includes locking folding legs that allows the machine to be used in a comfortable standing position. In addition, the machine can be operated with the folding legs stored position.

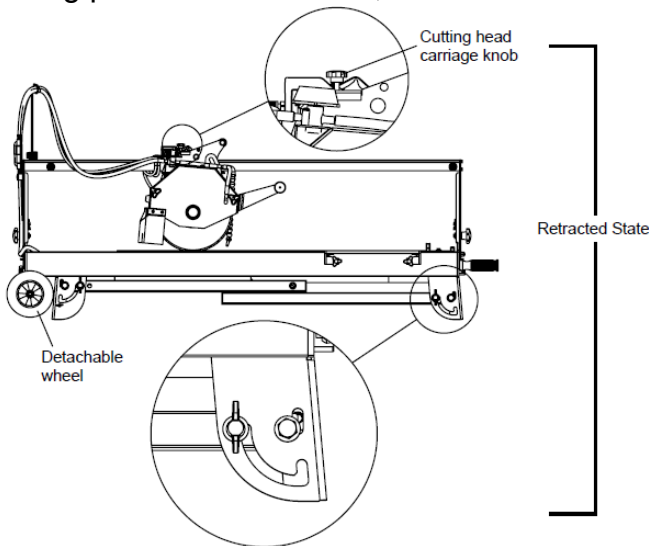

CTR1042L Folding Legs Retracted

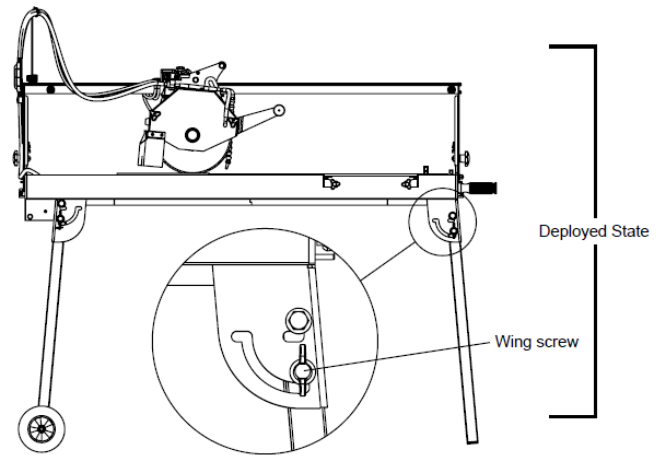

CTR1042L Folding Legs Deployed



WARNING: The machine can slip if care is not taken. Use two (2) able body personal. Folding legs present a pinch hazard.

1. With the machine sitting on a flat, clean surface in a well-lit area, verify that the Power Switch is in the OFF position and disconnect the CTR1042L from any power supply.
2. Verify that the cutting head locking knob is tightened, and the cutting head cannot move.

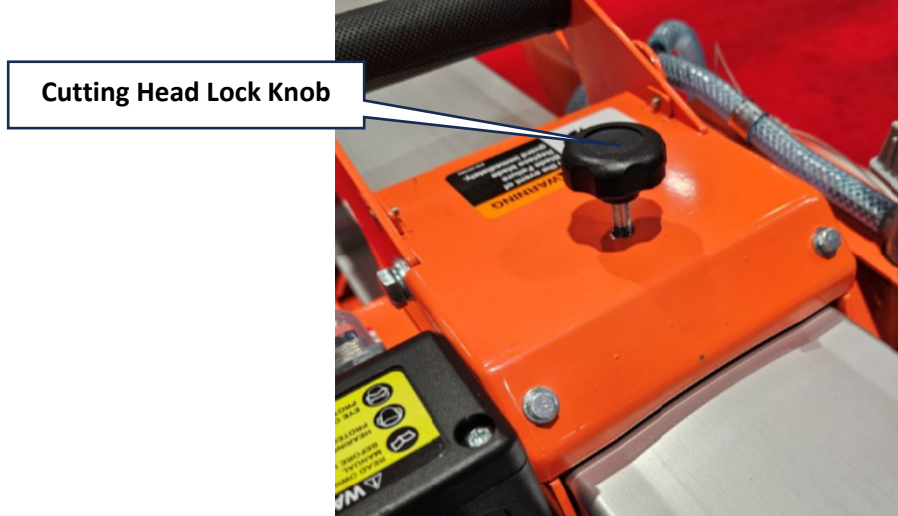

3. Loosen the wing nut for one (1) of the rear folding legs. See “**CTR1042L Folding Leg Components**” for details and locations of items.
4. Lean machine towards the front of the machine to provide enough clearance for the rear folding leg to fully extend.
5. Lower one rear leg at a time and lock in place. **NOTE:** *Verify that the folding leg has locked into the rear folding leg locking slot.*
 - a. Tighten the wing nut.
6. Repeat steps 3 to 5a for the remaining rear folding leg.
7. Loosen the wing nut for one of the front folding legs.
8. Lower one (1) front leg of the machine and lock in place. **NOTE:** *Verify that the folding leg is locked into the front folding leg locking slot.*
 - a. Tighten the wing nut.
9. Repeat steps 7 and 8a for the remaining front leg.
10. Verify that all of the legs are locked in position and that the wing nuts are fully tightened.
11. **NOTE:** *It is easier and safer to use two (2) able body personal when lowering the machine. Take care as the machine can slip.*



WARNING: The machine can slip if care is not taken. Use two (2) able body personal.

Attaching and using the Accessories:

Transport Wheels:

The CTR1042L features transport wheels that allow the machine to be rolled on the job site. The transport wheels can be installed on the rear folding legs or to the rear of the frame without the any tools.

1. Attaching the transport wheels to the rear frame of the CTR1042L
Allows for the CTR1042 to sit flat to the ground and the machine can be rolled when the legs are in the legs retracted.

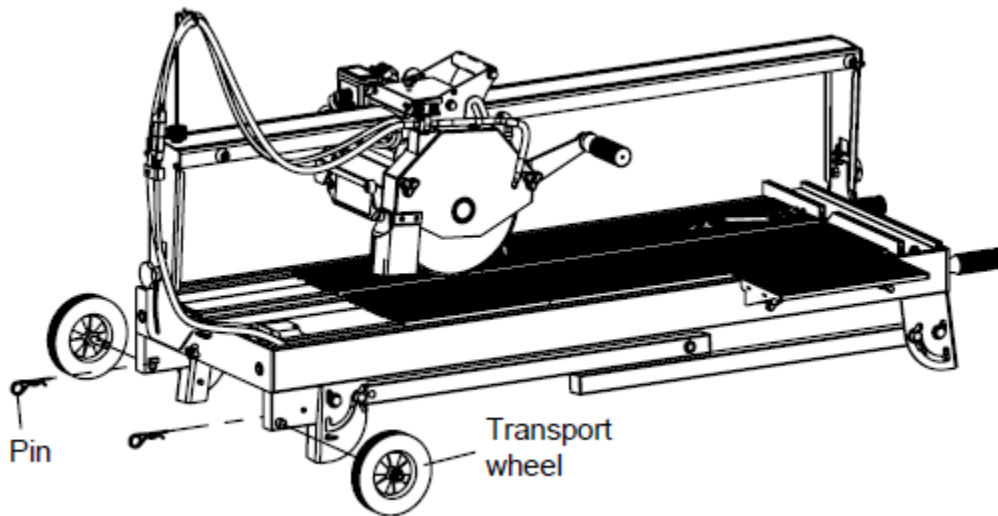

CTR1042L Transport Wheels attached to the rear of the frame.

2. Remove the Cotter Pin from each of the Transport Wheel Assemblies.
3. Slide the shaft of the Transport Wheel Thru the hole in the side of the frame. NOTE: The Transport Wheel will be outside of the frame.
4. Attach the Cotter Pin to the shaft of the wheel.
5. Repeat for the other side.
6. Attaching the transport wheels to the rear folding leg
Allows for rolling the CTR1042L when the folding legs are deployed.

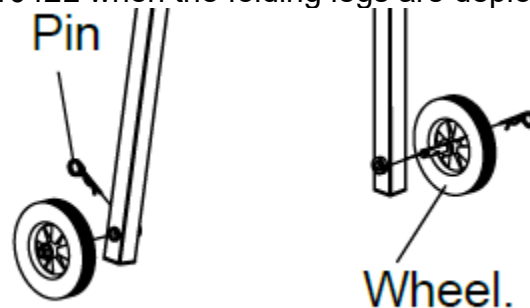

CTR1042L Transport Wheels attached to the rear of the rear folding legs

1. Remove the Cotter Pin from each of the Transport Wheel Assemblies
2. If the Rear Folding Leg is fully extended lift the machine up slightly
3. Slide the shaft of the Transport Wheel Thru the hole in the Rear Folding Leg. NOTE: The Transport Wheel will be outside of the Rear Folding Leg
4. Attach the Cotter Pin to the shaft of the wheel.
5. Repeat for the other side.

Transport Handles:

The CTR1042L includes four (4) transport wheels with cousin rubber grips that are designed to thread into holes located in each end of the water pan which allow for easier and more convenient moving and lifting of the machine.

1. Fully thread each of the transport handles into the threaded holes located at each end of the machine's frame.

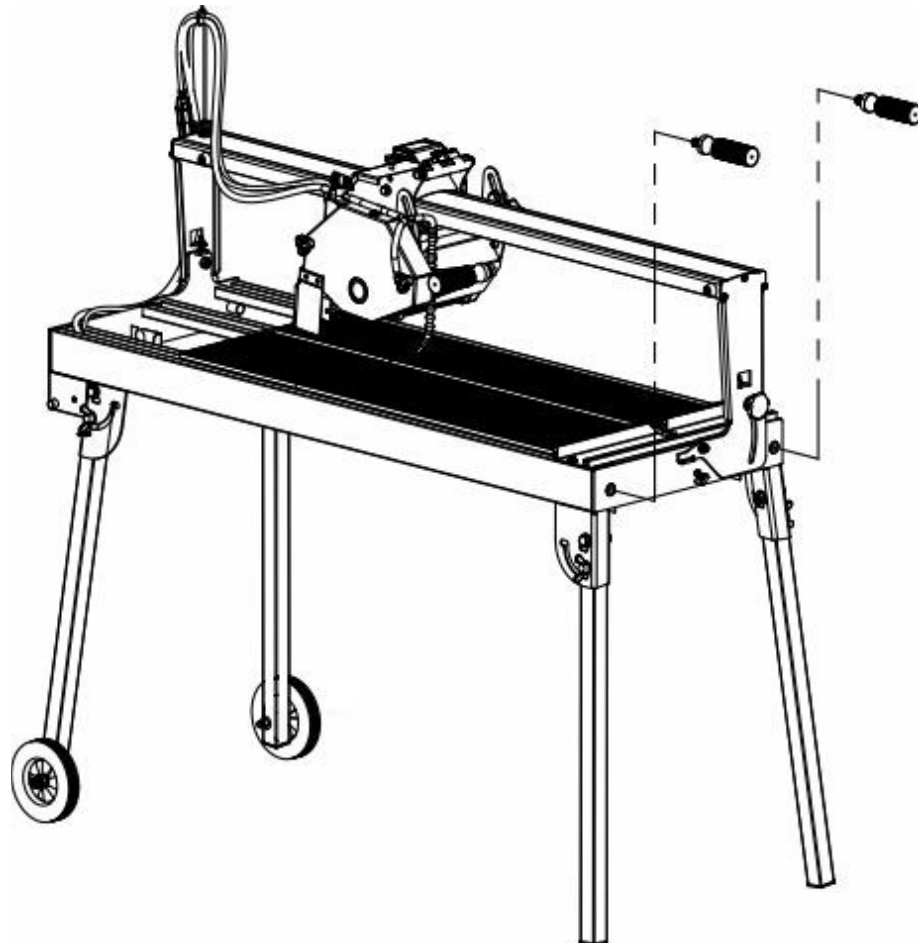

CTR1042L Transport Handle

Side Table Extension:

The Side Table Extension provides additional support when cutting wider materials.

1. Loosen the wing nuts located on the under side of the side table extension. **NOTE:** *Do not remove the wing nuts. Side Table Extension can be installed on either side of the CTR1042L.*
2. Position the side table extension anywhere along the frame of the water pan.
3. Slide the lip of the Side Table Extension over the frame of the water pan.
4. Level the Side Table Extension to the cutting table by:
 1. Tighten the Side Table Extension wing nuts to raise the Side Table Extension surface.
 2. Loosen the Table Extension wing nuts to lower the Side Table Extension surface.
 3. If a perfectly level surface is required use a bubble level during the above process.
 4. The side table extension can be placed anywhere along the length of the water pan.

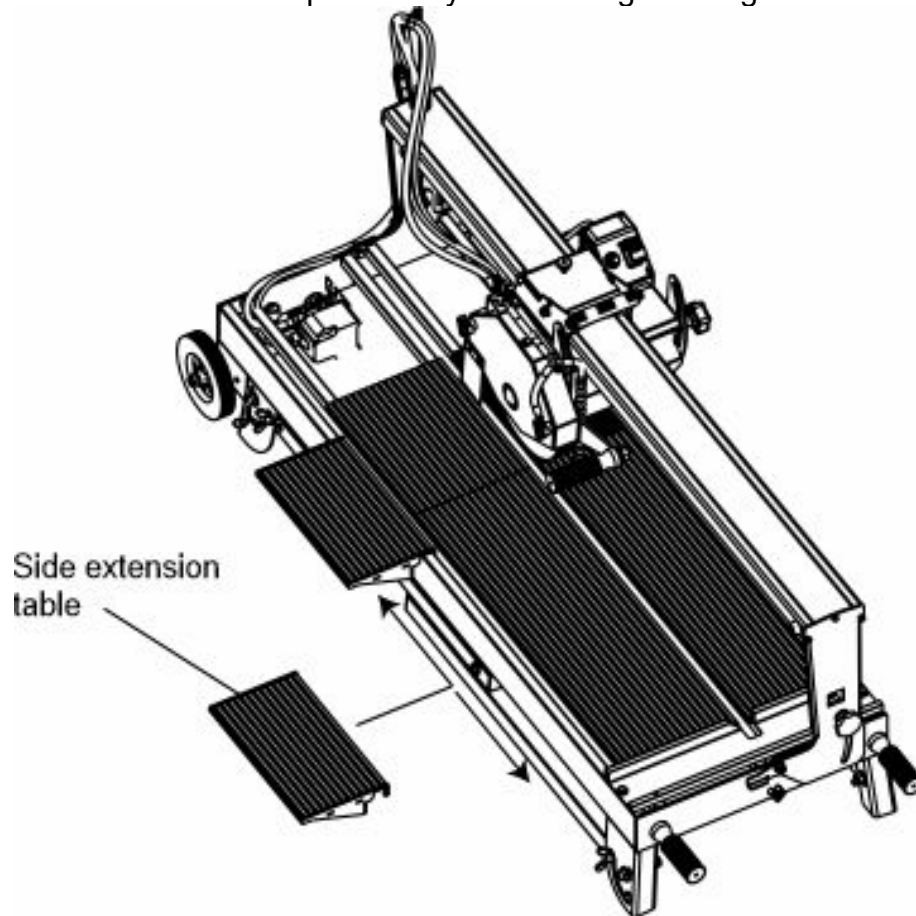

CTR1042L Side Table Extension

Power Cable and Water Hose Support:

The CTR1042L features a power cable and water hose support which suspends the components above the cutting head to make it easier to move the cutting head and to reduce the chances that the power cable and or water hose falling on the work or getting snagged during operation.

1. Locate the small hole on the top of the rail near the rear of the machine.
2. Place the end of the power cable and water hose support into the hole.

3. Place the power cable and water hose onto the hook of the power cable and water hose support as shown in the image below.
4. If needed the overhang length of the power cable and water hose can be adjusted by moving the power cable and water hose within the hook of the support.

Power Cord and Water Hose Support

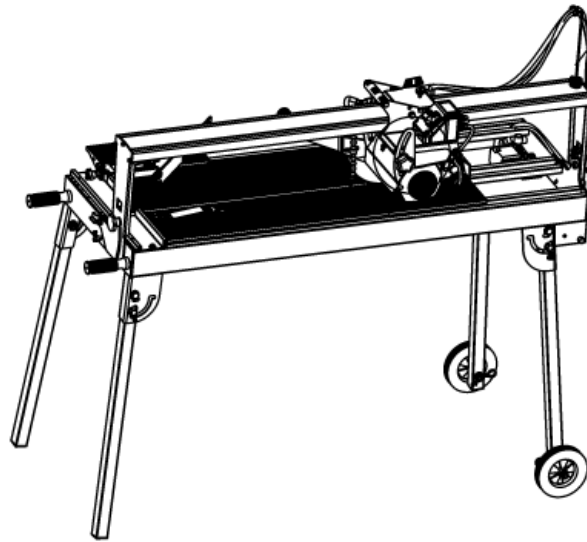

Power Cord and Water Hose Support

Water Pump and Overflow Plug:

The CTR1042L includes a water pump which can be removed from the machine and placed in a clean bucket of water when cutting materials which stain easily or for cleaning of the water system. In addition, the CTR1042L ships with a traditional drain plug which is attached to the machine with a tether to reduce the chances of being misplaced. When using an external water source, the overflow plug allows access water to be recirculated into a bucket or other separate water container not included with the CTR1042L.

Water Pump Installation:

1. Remove the water pump from the shipping box and check for any damage.
2. Place the water pump into the bracket located at the corner of the water tray.
3. Position the water outlet of the water pump so that it lays horizontally and connect the water hose from the blade guard to the water pump.
4. Plug the power cord into the 3-prong power receptacle located on the switch box housing.

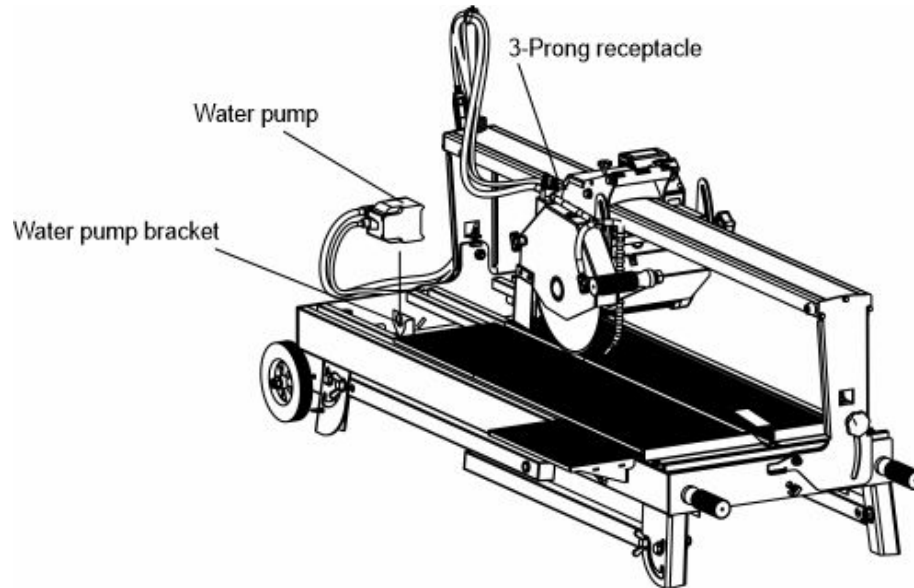

CTR1042L Water Pump Installation

Overflow Drain Plug:

1. Remove the traditional drain plug from the drain hole and drain any water in the machine.
NOTE: *The traditional drain plug is tethered to the CTR1042L with a lanyard and can be left laying in the water pan. It is recommended to clean the machine at this time.*
2. Insert the thin end of the overflow drain plug tube into the drain hole next to the water pump.
3. Place a bucket full of clean water under the drain plug hole. **NOTE:** *The bucket will contain any overflow water from the machine.*
4. Fill the water pan with clean water.
5. Place the water pump in the bucket of clean water.
6. To adjust the water level with the overflow, drain plug:
 1. Move the overflow plug UP to increase the water level in the water pan.
 2. Move the overflow plug DOWN to decrease the water level in the water pan.

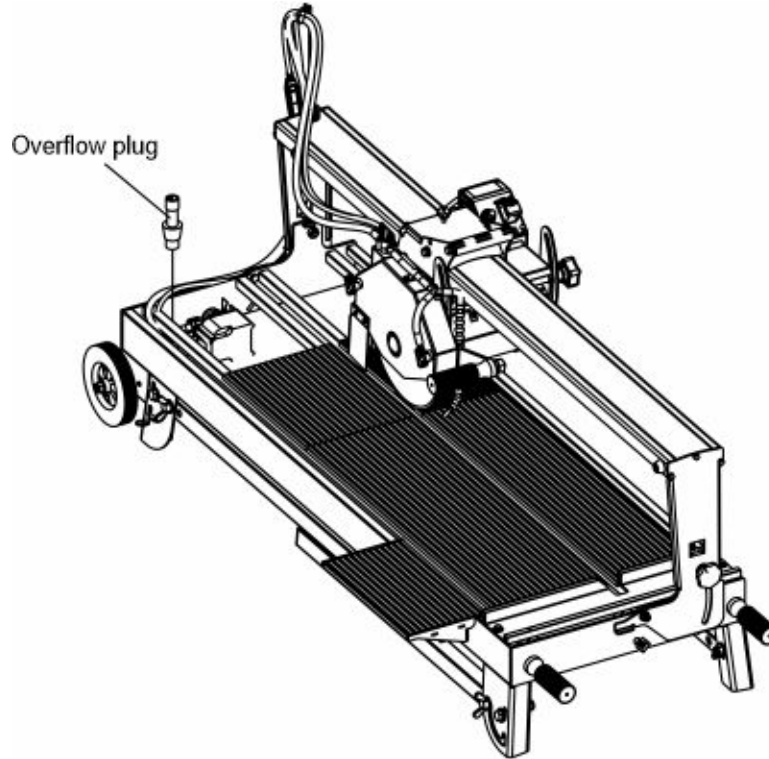

Adjustable Angle Guide:

The CTR1042L ships with an adjustable angle guide that allows the operator to properly align the material and also allows cutting of angles in the material. The adjustable angle guide will support cutting angles between 0° to 180° and ships completely assembled.

1. To install the adjustable angle guide remove it from the shipping box, accessory bag, or other location where it is stored.
2. Loosen but do not remove the guide knob located on the adjustable angle guide (**See Image: Adjustable Angle Guide**).
3. Insert the slot (**See Image: Adjustable Angle Guide Installation**) on the back stop of the CTR1042L.
4. Loosen but do not remove the angle knob located on the adjustable angle guide.
5. Move the adjustable angle guide to the desired position and tighten the guide knob.
6. Adjust the adjustable angle guide to the desired angle and tighten the angle knob.

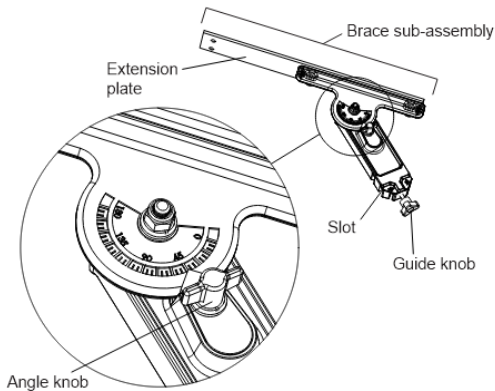

Adjustable Angle Guide

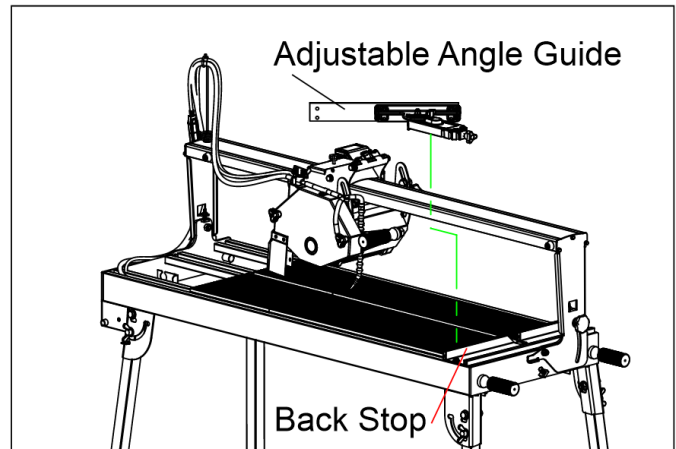

Adjustable Angle Guide Installation

Blade Installation

The CTR1042L is designed to be used with 8" or 10" diamond blades that are designed for cutting of tiles, stone, pavers and bricks. Do not use abrasive blades, wood cutting, blades, or other products that are not Diamond Steel Centered blades with a 5/8" arbor hole.

1. Verify that the power CTR1042L power switch is OFF and disconnect any power supply from the machine.
2. Loosen and remove the knobs securing the blade guard side and remove the blade guard side. NOTE: DO NOT remove the tethers that secure the knobs to the machine.
3. Loose and remove the blade shaft nut (LEFT HAND THREAD) with the included universal wrench by turning the nut clockwise. NOTE: It may be necessary to block the blade shaft from rotating.
4. Verify the direction of rotation of the Diamond Blade and match it to the CTR1042L. NOTE: The Blade Shaft direction of the of the CTR1042L the blade will rotate Clockwise when looking at the blade collars.
5. Place the blade onto the shaft making sure that the directional arrows are pointing in the direction of the shaft rotation.
6. After making sure that the blade is firmly placed against the inner flange, secure it into place with the outer flange and blade shaft nut.
With one hand hold the blade tightly and tighten the blade shaft nut with your free hand. Make certain that the nut is firmly tightened with the wrench provided, but do not over-tighten!
7. Replace the blade guard cover and secure with the knobs. NOTE: Do not run the CTR1042L without the blade guard cover in place and fully secured with both knobs.

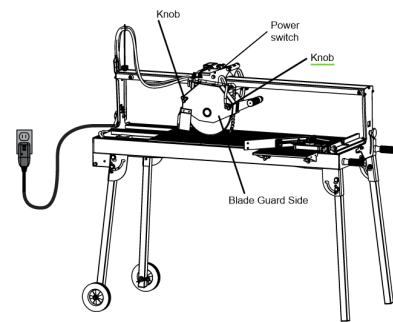

Warning: Only use the Ø8"~Ø10" blade for this saw. Setting smaller size of diamond blade may grab the material being cut, causing damage and possibly injury.

Cutting Depth

The CTR1042L has an adjustable depth of cut that can also be used to plunge cut and is used when cutting materials longer than 42". The CTR1042L is designed to cut tiles, stone, and other materials by plunge cuttings, plunge rip cutting (for extended length materials), cutting at a constant depth (jam cutting), and miter cutting up to 45°. The blade will always be pulled into the material.

1. Never adjust the cutting depth while the motor is running, disconnect the power supply before adjusting the depth of cut.
2. While holding the Plunge Hand loose the Depth Control Knob.
3. Adjust the blade position to the correct depth.
4. Retighten the Depth Control Knob.
5. Reconnect the power supply.
6. Make your cut by slowly pulling the blade into the material.
7. If cutting materials longer than 42" leave the Depth Control Knob loose.
 - a. When approaching the end of the tile press down on the Plunge Handle, this will increase the length of cut and allow cutting of 48" long materials.

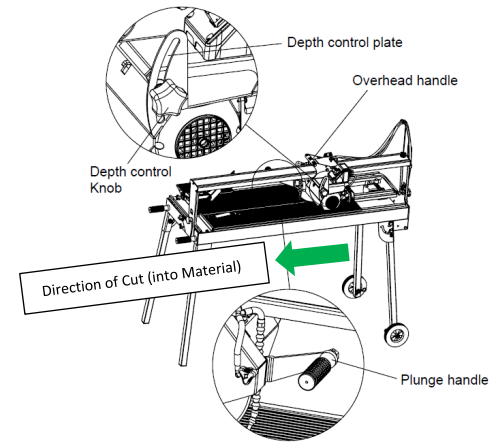

Cutting Depth and Direction

Blade Diameter and Depth of Cut Chart		
Blade Diameter	8" (203mm)	10" (254mm)
Cutting Depth	1-3/8" (35.6mm)	2-3/8" (61mm)

Cutting at a Constant Depth

When cutting at a constant depth the cutting head must be pulled into the material. The motor must be turned off before setting the cutting depth.

1. Never adjust the cutting depth while the motor is running, disconnect the power supply before adjusting the depth of cut.
2. While holding the Plunge Hand loose the Depth Control Knob.
3. Adjust the blade position to the correct depth.
4. Retighten the Depth Control Knob.
5. Reconnect the power supply.
6. Turn on the saw, verify that you have adequate water flow.
7. Slowly pull the blade into the material.
8. After completing the cut slowly return the cutting head to the original starting position.
9. Turn off the machine.

Plunge Cuts



WARNING: Never Adjust the Depth of Cut While the Blade is Rotating, or the Motor is On. Disconnect the Power Supply Before Making Adjustments.

The cutting of longer materials over 42" but under 48" can be made using the Plunge Cutting method. The cutting head will not be set to a fixed depth but is free to travel up and down.

1. Never adjust the cutting depth while the motor is running, disconnect the power supply before adjusting the depth of cut.
2. While holding the Plunge Hand loosen the Depth Control Knob.
3. Properly Secure the work piece so that it will not move.
4. Reconnect the power supply.
5. Verify that there is adequate water flow.
6. With the Cutting Head Fully raised move the cutting head to the desired starting point.
7. Slowly push down on the Plunge Handle.
8. Pull the blade slowly through the material.
9. When finished cutting slowly allow the blade to raise, turn off the power supply and move the blade back to the original starting position.

Miter Cuts



WARNING: Never Adjust the Miter Setting or Depth of Cut While the Blade is Rotating, or the Motor is On. Disconnect the Power Supply Before Making Adjustments.

The CTR1042L can preform accurate Miter Cuts up to 45°.

1. Never adjust the cutting depth while the motor is running, disconnect the power supply before adjusting the depth of cut.
2. Loosen the Post Knobs at both ends of the saw.
3. Set the Bridge (aka Rail) to the desired angle by using both hands to firmly hold and rotate the Bridge to angle needed and tighten the Post Knobs. NOTE: Fully stopped is 45°. This step is easier with two people.
4. Place the work piece on the cutting table and secure it from moving.
5. Set the blade to the required cutting depth.
6. Verify that the Cutting Depth Knob is tightened.
7. Verify that the Post Knobs are Tightened.

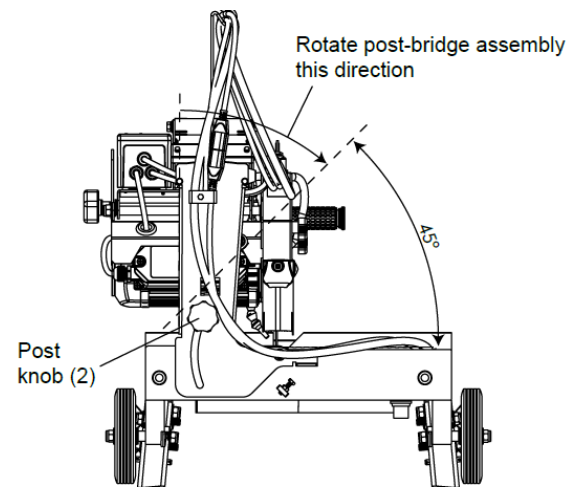

Miter Adjustment

8. Reconnect the power.
9. Turn on the machine.
10. Verify that adequate water flow is present over the blade.
11. Slowly pull the blade thru the material
 - a. If binding this is a sign that the material is moving, the Post Knobs are not tight, or the blade has lost its tension, or the diamonds are not exposed.
12. When the cut is completed turn off the saw and return the blade to the original starting position.

CTR1042L Electrical

Motor Specifications:

Voltage: 115-volt
Cycles: 60Hz
Amperage: 15 Amp
Horsepower: 1.5 HP
Watts: 1,100 watts
Motor RPM: 3,600 RPM
Electrical Motor Specifications

Table 3. Extension Cord Chart	
Wire Gauge	115V Max Length
12 AWG	25' (7.6 m)
10 AWG	50' (15.2 m)
8 AWG	75' (22.8 m)

Recommendations:

- It is recommended that a 15 AMP CIRCUIT be used while operating this saw, for best performance use a 20 AMP CIRCUIT. This will prevent any loss of power or interruption.
- Always plug saw as close as possible to the power source while operating. This will allow you to receive optimum electricity.

Extension Cords:

Most motor trouble is the result of too small gauge or too long of extension cord. **Cords must be one piece and as short as possible.** Cords should be no longer than shown on Table 3:

Extension Cord Maximum Length Chart (see above). Norton Construction Products is not responsible for damage to motors due to the use of extension cords that are too small or too long.

WARNING:

To avoid permanent motor damage you must use the correct extension cord. Never use more than one extension at a time. Follow the chart below for proper size.

Electrical Supply:

The CTR1042L can only be used on a 115-volt 60 Hz 1 Phase circuit with a minimum of a 15-amp breaker, for best performance use a 20-amp breaker. **Before connecting the CTR1042L to the electrical supply, make sure the voltage is 115v. Connecting the CTR1042L to voltages higher than may result in motor damage and is not covered under any warranty.**

Generator:

Using the machine with a generator that is less than the recommend output can result in motor damage and is not covered under warranty. Only use with a generator that is capable of continuous put of 4,000 w (4kW) at 20 amps or greater.

WIRING DIAGRAM

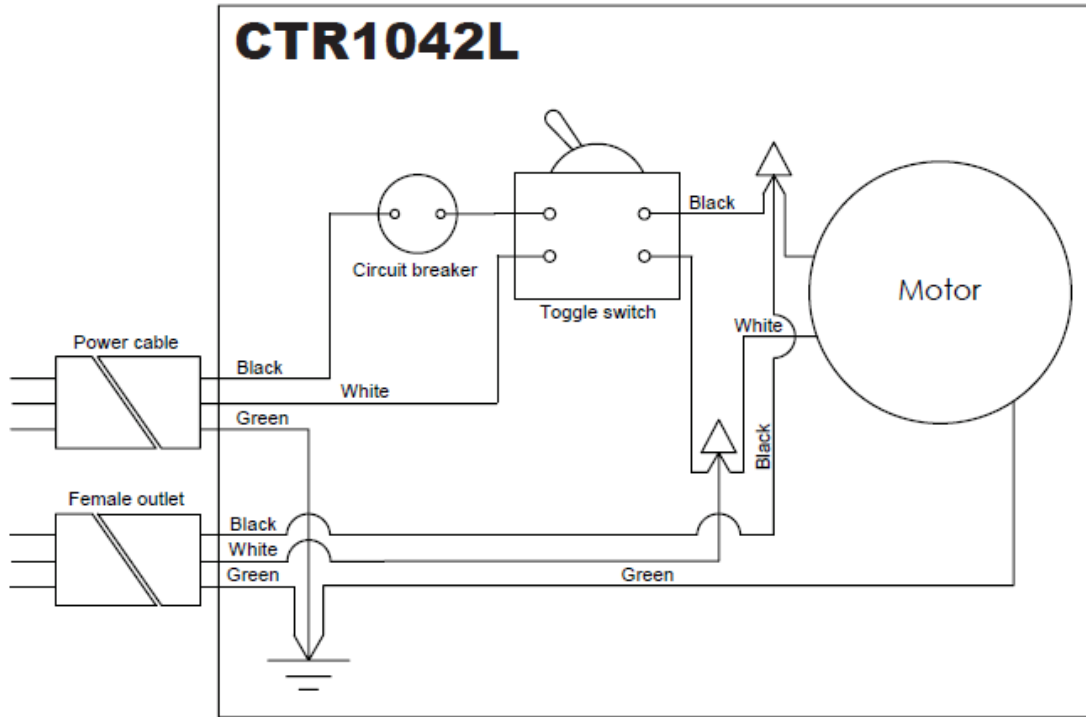

CTR1042L Wiring Diagram

Ensure that the Power Cord and Extension Cord does not sit in any water. Always make sure to have a drip loop in the power cable.

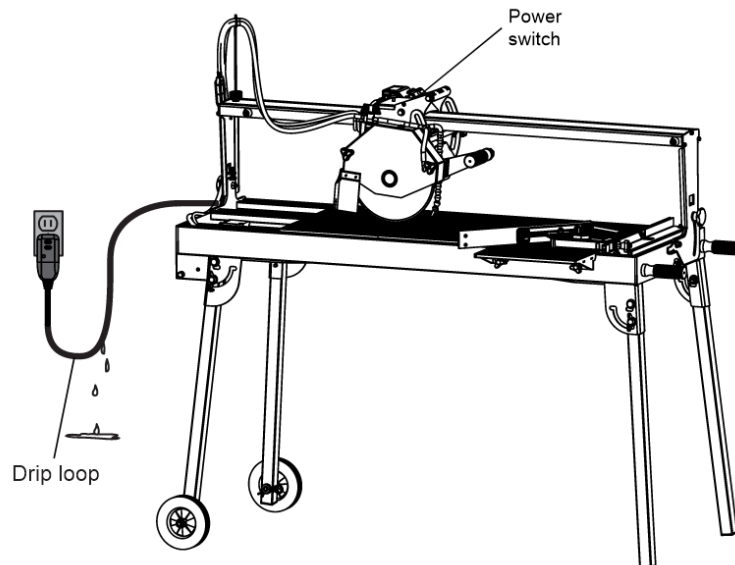

Drip Loop

Circuit Breaker During Start Up or Not Cutting:

- Verify that the power supply voltage matches the motor name plate voltage.



Failure to run the motor on the proper voltage will damage the motor and is not covered under warranty. Improperly wired motors are not covered under warranty.

- Verify that the circuit breaker is correct for the machine and voltage being used.
 - Although the CTR1042L can be used on a 15A circuit a 20A is recommend for best performance.
- Verify that the Extension Cord meets the requirements on See: **Extension Cords** page 26.
- Have a qualified Electrician verify that the Electrical Connections are correctly made.
- If using a generator, verify that it meets the minimum requirements See: **Generators** on page 26.
- Remove the extension cord from the machine and connect the machine directly to the power supply, if the problem disappears the issue is low voltage due to the extension cord being too thin of gauge, too long, spliced together, or a combination of all.
- Change power source if the problem disappears the issue is with the original power source (Low voltage, low amperage breaker, or damage breaker)
Most motor issues are due to low voltage, under rated circuit breakers, and or extension cord issues.

Circuit Breaker Trips while cutting: - This is an issue with the Blade or Cutting Method being used or too long/thin extension cord or extremely low voltage at the machine.

- Verify that the Blade Being used is correct for the material being cut.
- Verify that the Blade is properly exposed.
- Verify that the Blade is installed properly.
- Verify the cutting method. Forcing the Blade into the material is a sign that either the Blade is **NOT** correct for the material being cut or an inexperienced operator. Let the Blade and Machine work for you do not work for the Blade and Machine.
- If cutting hard materials do not use General purpose blades. General purpose blades are designed to cut multiple soft to medium hardness materials and will not preform properly when cutting harder bricks, pavers, or other building materials. In correct blade usage is the number one root cause for motor issues. If you need assistance choosing the correct blade for the material being cut, contact customer service at 1-800-554-8003.
- Verify Extension Cord Length and Gauge See: **Extension Cords** page 26.
- Verify voltage at the machine must be 115v.

Overload Protector (Thermal) Trips – This is a sign of Low Voltage, Incorrect Blade for Material being cut, or forcing the Blade through the material.

- Verify Voltage at the machine!
- Verify that the Extension Cord meets the requirements on See: **Power Supply** page 26.
- Verify the cutting method. Forcing the Blade into the material is a sign that either the Blade is **NOT** correct for the material being cut or an inexperienced operator. Let the Blade and Machine work for you do not work for the Blade and Machine.
- If the Overload Protector trips immediately when the unit is turned on this is a sign of extremely low voltage or damage Overload Protector.
- Clean Motor by blowing out the fan cover with compressed air.
- Check the Motor for a damaged.

- To reset the Overload Protector (Thermal) let the motor cool down for 5 to 10 minutes and then press the Thermal Overload Protector to reset. The Thermal Overload Protector will not reset until the unit has fully cooled.

Electrical Troubleshooting

Verify voltage to the motor 115v/60 Hz/1 Phase

2. Verify extension cord See: **Extension Cords** page 15
3. What is the motor doing when switch is turned on (nothing, humming, tries to turn on but shuts off, tripping of circuit breaker) It could be a dirty air filter, a faulty start, or a tripped/damage power supply circuit breaker.

Nothing happens when the power switch is turned on:

- a) No power
- b) Tripped Power Supply Circuit Breaker
- c) Tripped Overload Protector on machine (see: **Overload Protector (Thermal) Tips** page 18.

Humming or strange noises from motor:

- a) Damage motor
- b) Water in the motor
- c) Low voltage

Tries to turn on but shuts off:

- a) Power supply Circuit Breaker verify if correct see **Power Supply** page 26.
- b) Too long or thin extension cord see **Extension Cords** page 26.
- c) Overload Protector (Thermal) issues see **Overload Protector (Thermal) Tips** page 17.
- d) Low voltage at the machine see **Power Supply** page 26.

Tripping of Circuit Breaker:

- a) If tripping while starting machine
Circuit Breaker issue: weak, damage, to low amperage
- b) If tripping while cutting any material:
Incorrect blade for the material being cut.

5. What are you cutting?

6. Wet/dry?

If cutting dry give the blade a chance to cool off and breath. The heat will build up and can affect the performance of the motor as the blade lose tension.

7. What blade is being used?

Use the correct blade for the material being cut.

9. What cutting method is being used. Change cutting methods.

9. May need to go to [Authorized Service Center](#) to diagnose and repair

Wet cutting Blades

DO'S

- Use proper PPE
- Inspect blades daily for cracks or uneven wear.
- Always use appropriate blade for material being cut.
- Inspect arbor shaft for uneven wear before mounting blade.
- Always use blades with the correct arbor shaft size.
- Ensure that blade is mounted in the correct direction.
- Secure the blade to the arbor with a wrench.
- Use proper safety equipment when operating the saw.
- Periodically check the blade for cracks or bond fatigue.
- Always have a continuous flow of water on both sides of blade.

DON'TS

- Do not operate the saw without safety guards in position.
- Do not operate the saw with blades larger than 7".
- Do not cut dry with blades marked "Use Wet".
- Do not exceed manufacturer's recommended maximum RPM.
- Do not force blade into material let blade cut at its own speed.

Dry cutting Blades

DO'S

- Follow ALL OSHA, State and Local requirements and rules for Dry Cutting
- Use proper PPE
- In addition to the following, always follow wet recommendations.
- Use appropriate blade for material being cut.
- Inspect segment blades for segment cracking or loss.
- Do not use damaged blades.
- Use proper safety equipment when operating the saw.

DON'TS

- In addition to the following, always follow wet recommendations.
- Do not make long cuts with dry blades--allow them to air cool periodically.
- Do not use the edge or side of blade to cut or grind.
- Do not attempt to cut a radius or curve.
- Do not cut too deep or too fast into the material.

Saw Maintenance	
<i>Maintenance Interval</i>	<i>What to do for maintenance and care</i>
After every use of the machine	Remove dirty water from container. Remove dirt and mud from the bottom of the container. Rinse the immersion pump with fresh water to prevent water pump clogging from residual dirt.
After wet cleaning and before using the machine again	Connect the machine to an electric power outlet equipped with a "GFCI" power breaker. If the safety power breaker cuts off the electrical power supply, do not try to operate the machine but have it checked by an authorized dealer first.
Before not using the machine for a prolonged period of time	Clean and lubricate all movable parts.
After not using the machine for a prolonged period of time	Check that the stand is safely fixed. Check that all screw joints and nuts are fixed. Check that the roller table is in its guides and that it easily moves to and from. With the saw blade removed, switch on the motor for an instant and switch it off again. If the motor does not run, have the machine inspected by a qualified electrician. Check that the immersion pump works properly. Turn on the cooling water tap and switch the machine on. If the pump does not give any water or only a little, switch the machine off at once. Clean the pump or replace if necessary.
Ambient temperature below 32 F (operation in winter)	To prevent the water in the pump and cooling system from freezing, remove the water after using the machine or when there will be a long break. Make sure that the cooling system is entirely drained so that there is no water left inside the pump, water hose and bearing housing!

Troubleshooting		
<i>Problem</i>	<i>Possible Cause</i>	<i>Solution</i>
Machine does not run when switched on	<ul style="list-style-type: none"> • Power cord not properly fixed/plugged in • Power cord defective • Main power switch defective. • Loose electrical connection inside the electric system. • Motor defective 	<ul style="list-style-type: none"> • Check that the machine is properly connected to the power supply. • Have the power cord checked, replace if necessary. • Have the main power switch checked and replaced, if necessary, by a qualified electrician. • Have the whole electric system of the machine checked by a qualified Electrician. • Have the motor checked and replaced, if necessary, by a qualified technician.
Motor stops (power cut out)	<ul style="list-style-type: none"> • Too much pressure exerted while cutting. • Incorrect specification for saw blade. • Saw has a defective electric system 	<ul style="list-style-type: none"> • Exert less pressure when cutting. • Use a saw blade which corresponds to the material being cut. • Have the electric system of the saw checked by a qualified technician.

Troubleshooting (continued)		
<i>Problem</i>	<i>Possible Cause</i>	<i>Solution</i>
Poor machine performance little power	<ul style="list-style-type: none"> • Power cord/extension cable too long or cable still wound up inside cable drum. • Power network is insufficient. • Drive motor no longer runs at rated speed RPM 	<ul style="list-style-type: none"> • Use a Power cord extension cable of the rated length, use a cable drum with cable fully extended. • Observe the electrical ratings of the machine and connect it only to a power network which complies with these ratings. • Have the motor checked by a qualified electrician and have it replaced if necessary?
Saw blade is blunt	<ul style="list-style-type: none"> • Power cord/extension cable too long or cable still wound up inside cable drum. • Power network is insufficient. • Drive motor no longer runs at rated speed RPM 	<ul style="list-style-type: none"> • Use a Power cord extension cable of the rated length, use a cable drum with cable fully extended. • Observe the electrical ratings of the machine and connect it only to a power network which complies with these ratings. • Have the motor checked by a qualified electrician and have it replaced if necessary?
Appearance of cut is not optimal	<ul style="list-style-type: none"> • Poor tension in the blade material • Too much load placed on the saw blade. • Diamond segments are blunt. 	<ul style="list-style-type: none"> • Return saw blade to manufacturer. • Use a suitable saw blade. • Sharpen the saw blade
The center hole in the saw blade has become wider due to wear	<ul style="list-style-type: none"> • The saw blade has slipped on the motor. shaft when running 	<ul style="list-style-type: none"> • The arbor of the saw blade must be fitted w/ appropriated adaptor ring. • Check the receiving flange and have it replaced if necessary
Saw blade shows blooming colors	<ul style="list-style-type: none"> • Saw blade overheating due to a lack of cooling water. • Lateral friction when cutting 	<ul style="list-style-type: none"> • Ensure optimum flow of water. • The material feed is too high; proceed more slowly
Grinding marks on the saw blade	<ul style="list-style-type: none"> • Material is not being fed parallel to blade. • Poor tension in the blade material • Too much load on the saw blade 	<ul style="list-style-type: none"> • Ensure that the direction of feed is absolutely parallel to the saw blade. • Adjust roller table. • Have the saw blade tensioned. • The material feed is too high, proceed more slowly

Ordering Information

1. Provide the model number and serial number of the machine from the machine name plate.
2. Provide the **UPC** number, part number, and description of part.
3. Whenever alternate parts are shown due to product improvement, inspect the part you have and provide additional description as necessary.
4. Specify mode of shipping desired, for example, parcel post, truck, air freight, UPS., best way, etc.

Contact Customer Service:
Saint-Gobain Abrasives
2770 West Washington
Stephenville, TX 76401

Phone: 800-554-8003
Fax: 254-918-2312

Web: www.nortonabrasives.com

NOTE: All Parts Are Sold as Individual (each) Unless Noted Otherwise

Use Only Clipper Diamond Blades. Contact your local Norton Clipper Distributor or our Customer Service at 800-554-8003 for the best blade for the application.

All parts are designated as either Service Parts (S) or Wear Parts (W) in the Type column in the parts listing. Wear parts are worn out through normal use of the machine. The wear period depends on the intensity of use of the machine, handling, and maintenance of the machine. Wear parts must be serviced and eventually changed following the indications of the manufacturer. Any wear due to normal use of the machine will not be considered as a case of warranty for items designated as Wear Parts (W). For best performance and life Genuine Norton Clipper replacement parts should always be used. Changes to part specifications, are subject to change without notice.

Main Assembly Group

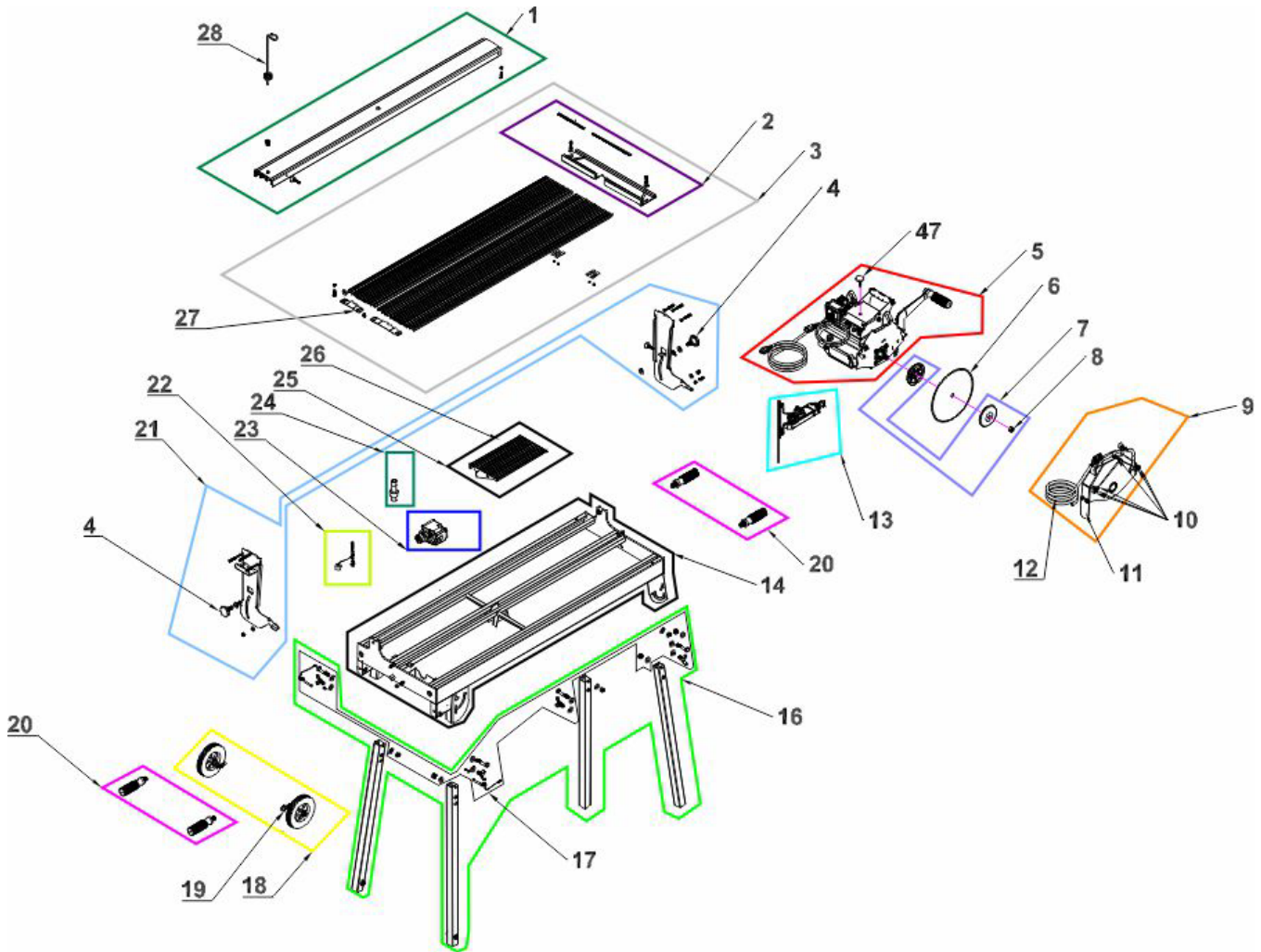

Main Frame Group

#	UPC	Description	QTY	Type
1	70184634068	RAIL ASSY W/HWD CTR1042L	1	S
2	70184634069	RULER GUIDE CTR1042L	1	W
3	70184634071	TABLE KIT W/HWD CTC1042L	1	S
4	70184628213	KNOB w/THREADED STUD CTR1042L	1	S
5	70184634070	CUTTING HEAD ASSY CTC1042L	1	S
6		<i>10" Diamond Blade contact customer service for best blade</i>	1	W
7	70184634072	BLADE COLLAR KIT W/SHAFT NUT CTR1042L	1	S
8	70184634073	BLADE SHAFT NUT	1	S
9	70184634074	GUARD BLADE ASSY CTR1042L	1	S
10	70184634075	HARDWARE KIT BLADE GUARD CTR1042L	1	S
11	70184634078	SPLASH GUARD KIT CTR1042	1	W
12	70184634079	WATER SYSTEM ASSY CTR1042L	1	W
13	70184634080	ADJUSTABLE ANGLE GUIDE W/HWD	1	S
14	70184634101	FRAME ASSY CTR1042L	1	S
16	70184634081	FOLDING LEG ASSY W/HWD	1	S
17	70184634102	HARDWARE KIT FOR FOLDING LEG CTR1042L	1	S
18	70184634082	WHEEL KIT W/HWD CTR1042L	1	W
19	70184634083	HARDWARE KIT FOR WHEELS CTR1042L	1	S
20	70184634084	HANDLE LIFTING CTR1042L (Set of 4)	1	S
21	70184634103	UPRIGHT SUPPORT ASSY CTR1042L W/HWD	1	S
22	70184680911	DRAIN PLUG w/CHAIN CTR1042L	1	W
23	70184634085	WATER PUMP	1	W
24	70184634086	PLUG OVERFLOW CTR1042L	1	W
25	70184634087	SIDE TABLE EXTENSION W/HWD CTR1042L	1	S
26	70184634088	HARDWARE KIT SIDE TABLE EXT CTR1042L	1	W
27	70184634089	HARDWARE KIT TABLE CTR1042L	1	S
28	70184634085	SUPPORT POWER CORD CTR1042L	1	S
47	70184635042	KNOB CUTTING HEAD STOP CTR1042L	1	S

Type: S = Service Part, W = Wear Part, All Parts Are Sold as Individual (each) Unless Noted Otherwise

Use the UPC Number When Ordering

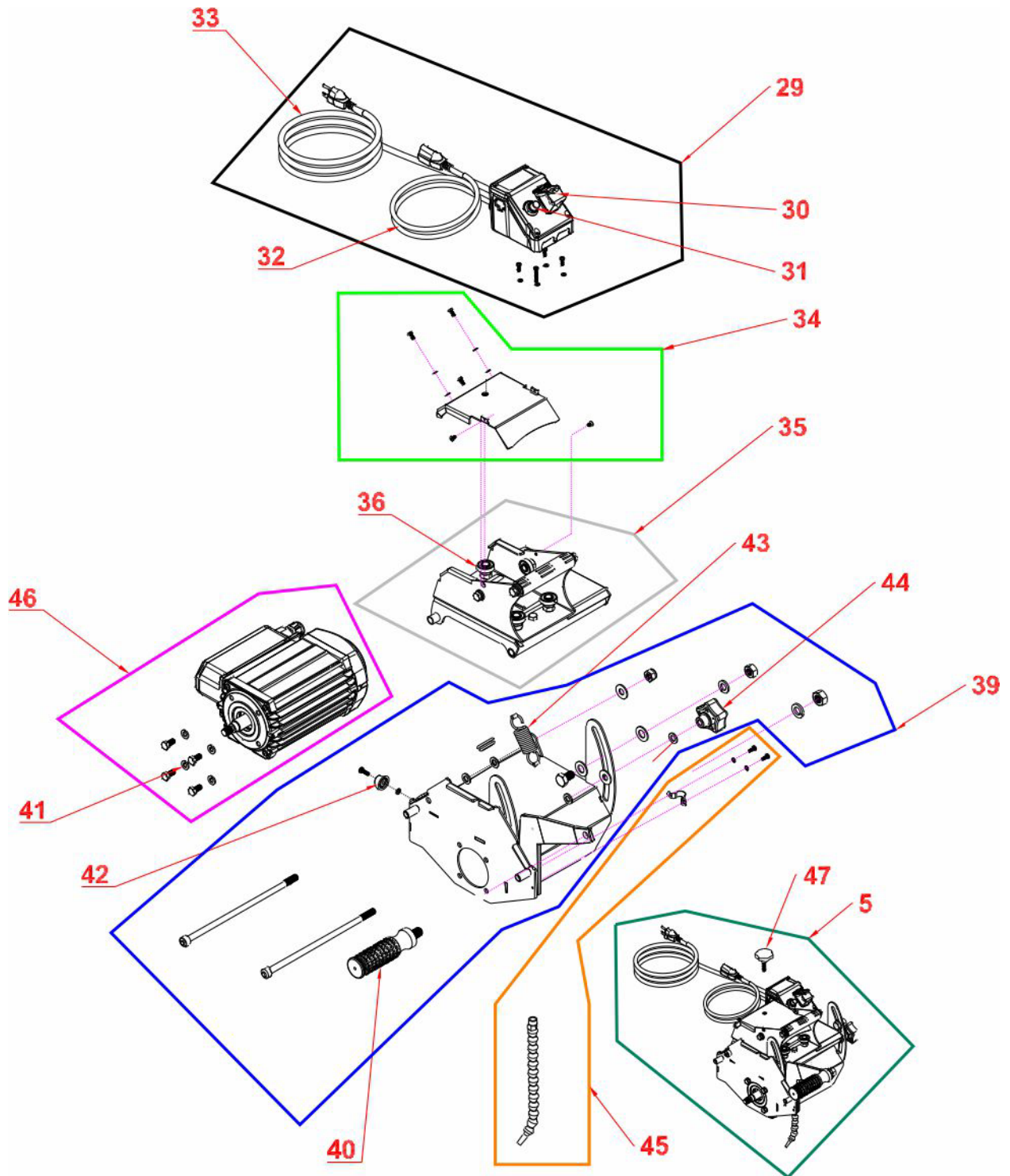

Cutting Head Group

#	UPC	Description	QTY	Type
29	70184634090	POWER SWITCH ASSY	1	S
30	70184634091	SWITCH ON/OFF TOGGLE – <i>Toggle Switch Only, Rubber Boot and Metal Cover sold separately see below for details</i>	1	W
	70184646880	BOOT RUBBER TOGGLE SWITCH	1	W
	70184600875	COVER TOGGLE SWITCH	1	W
31	70184627019	SWITCH RESET 18A w/RUBBER BOOT	1	W
32	70184634092	CORD WATER PUMP CTC1042L	1	W
33	70184634093	CORD POWER IN CTC1042L	1	W
34	70184634094	COVER CUTTING HEAD w/HWD	1	S
35	70184634095	CARRIAGE w/ROLLER BEARING & HWD	1	S
36	70184634104	ROLLER BEARING w/HARDWARE KIT	1	W
39	70184634096	CUTTING HEAD ASSY CTR1042L	1	S
40	70184634097	HANDLE CUTTING HEAD CTR1042L	1	S
41	70184634105	HARDWARE KIT FOR CUTTING HEAD CTR1042L	1	S
42	70184634106	STOPPER FOR CUTTING HEAD CTR1042L	1	W
43	70184634098	SPRING CUTTING HEAD CTR1042L	1	W
44	70184634099	KNOB CUTTING DEPTH ADJUSTMENT CTR1042L	1	S
45	70184634100	WATER HOSE FLEXIBLE ASSY	1	W
46	70184634107	MOT ASSY W/HARDWARE CTR1042L	1	S
47	70184635042	KNOB CUTTING HEAD STOP CTR1042L	1	S

Type: S = Service Part, W = Wear Part, All Parts Are Sold as Individual (each) Unless Noted Otherwise

Use the UPC Number When Ordering

NOTES

WARNING

Some dust created by power sanding, sawing, grinding, drilling, and other construction activities contains chemicals known to cause cancer, birth defects or other reproductive harm. Some examples of these chemicals are:

- Lead from lead-based paints,
- Crystalline silica from bricks and cement and other masonry products, and
- Arsenic and chromium from chemically-treated lumber.

Your risk from these exposures varies, depending on how often you do this type of work. To reduce your exposure to these chemicals: work in a well ventilated area, and work with approved safety equipment, such as those dust masks that are specially designed to filter out microscopic particles.



REDEFINING
JOBSITE MUSCLE™

www.facebook.com/NortonAbrasivesNA | www.youtube.com/NortonAbrasives | www.nortonabrasives.com

USA CUSTOMER SERVICE:

Toll Free Phone: 1 (800) 554-8003
Toll Free Fax: 1 (800) 443-1092

CANADA CUSTOMER SERVICE:

Toll Free Phone: 1 (800) 263-6565
Toll Free Fax: 1 (800) 561-9490

© Saint-Gobain.

Norton, Norton Clipper, "Redefining Jobsite Muscle" and "Transforming surfaces...and beyond" are trademarks of Saint-Gobain. All other trademarks are the property of their respective owners.

