

The Metro[®] *Operating Instructions*

For 3" through 10" lines
(75mm—250mm)



Your Metro is designed to give you years of trouble-free, profitable service. However, no machine is better than its operator.

Read, understand and follow all safety warnings and instructions provided with the product. Failure to follow the warnings and instructions may result in electric shock and/or serious injury. Save all warnings and instructions for future reference.

SAVE THESE INSTRUCTIONS!

General
PIPE CLEANERS

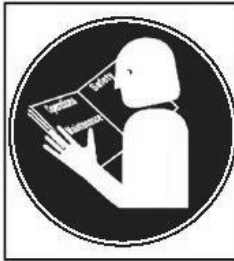

! WARNING

Read and understand operator's manual before using this machine. Failure to follow operating instructions could result in death or serious injury.

WARNING! Read and understand all instructions. Failure to follow all instructions listed below may result in electric shock, fire and/or serious personal injury. Replacement manuals are available upon request at no charge, or may be downloaded from our website, www.drainbrain.com. Instructional videos are available for download on our website, and may be ordered. If you have any questions or problems, please call General's customer service department at 412-771-6300.

SAVE THESE INSTRUCTIONS!

These instructions are intended to familiarize all personnel with the safe operation and maintenance procedures for The Metro.

SAFETY SYMBOLS



This is the safety alert symbol. It is used to alert you to potential personal injury hazards. Obey all safety messages that follow this symbol to avoid possible injury or death.

! DANGER

DANGER indicates a hazard with a high level of risk which, if not avoided, will result in death or serious injury.

! WARNING

WARNING indicates a hazard with a medium level of risk which, if not avoided, could result in death or serious injury.

! CAUTION

CAUTION indicates a hazard with a low level of risk which, if not avoided, will result in minor or moderate injury.

! WARNING



Electric shock resulting in death can occur if you plug this machine into an improperly wired outlet. If the ground wire is electrified, you can be electrocuted by just touching the machine, even when the power switch is off. A ground fault circuit interrupter will not protect you in this situation. Use a UL approved tester to determine if the outlet is safe.



Do not operate power tools in explosive atmospheres, such as in the presence of flammable liquids, gases, or dust. Power tools create sparks which may ignite the dust or fumes.

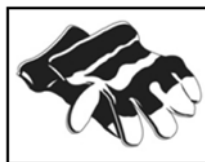

Only wear leather gloves. Never use any other type of glove, such as cloth, rubber, or coated gloves. Never grasp a rotating cable with a rag. These items could become wrapped around the cable and cause serious injury.



Always wear safety glasses and rubber soled, non-slip shoes. Use of this safety equipment may prevent serious injury.



Never operate machine with belt guard removed. Fingers can get caught between belt and pulley.



Do not overstress cables. Overstressing cables may cause twisting, kinking, or breaking of the cable and may result in serious injury.

! WARNING

This product can expose you to chemicals including lead, which is known to the State of California to cause cancer and birth defects or other reproductive harm. For more information go to www.P65Warnings.ca.gov.

GENERAL POWER TOOL SAFETY WARNINGS*

WARNING

Read all safety warnings, instructions, illustrations and specifications provided with this power tool. Failure to follow all instructions listed below may result in electric shock, fire, and/or serious injury.

SAVE ALL WARNINGS AND INSTRUCTIONS FOR FUTURE REFERENCE.

*The text used in the general power tool safety warnings section of this manual is as required from the applicable UL/CSA standard. This section contains general safety practices for many different types of power tools. Not every precaution applies to every tool. And some do not apply to this tool.

Work Area Safety

1. **Keep work area clean and well lit.** Cluttered or dark areas invite accidents.
2. **Do not operate power tools in explosive atmospheres, such as in the presence of flammable liquids, gases or dust.** Power tools create sparks which may ignite the dust or fumes.
3. **Keep children and bystanders away while operating a power tool.** Distractions can cause you to lose control.

Electrical Safety

1. **Power tool plugs must match the outlet.** Never modify the plug in any way. Do not use any adapter plugs with earthed (grounded) power tools. Unmodified plugs and matching outlets will reduce risk of electric shock.
2. **Avoid body contact with earthed or grounded surfaces, such as pipes, radiators, ranges and refrigerators.** There is an increased risk of electric shock if your body is earthed or grounded.
3. **Do not expose power tools to rain or wet conditions.** Water entering a power tool will increase the risk of electric shock.
4. **Do not abuse the cord.** Never use the cord for carrying, pulling or unplugging the power tool. Keep cord away from heat, oil, sharp edges or moving parts. Damaged or entangled cords increase the risk of electric shock.
5. **When operating a power tool outdoors, use an extension cord suitable for outdoor use.** Use of a cord suitable for outdoor use reduces the risk of electric shock.
6. **If operating a power tool in a damp location is unavoidable, use a ground fault circuit interrupter (GFCI) protected supply.** Use of a GFCI reduces the risk of electric shock.

Personal Safety

1. **Stay alert, watch what you are doing and use common sense when operating a power tool.** Do not use a power tool while you are tired or under the influence of drugs, alcohol or medication. A moment of inattention while operating power tools may result in serious personal injury.
2. **Use personal protective equipment. Always wear eye protection.** Protective equipment such as a dust mask, non-skid safety shoes, hard hat or hearing protection used for appropriate conditions will reduce personal injuries.

3. **Prevent unintentional starting. Ensure the switch is in the off-position before connecting to power source and/or BATTERY pack, picking up or carrying the tool.** Carrying power tools with your finger on the switch or energizing power tools that have the switch on invites accidents.
4. **Remove any adjusting key or wrench before turning the power tool ON.** A wrench or a key left attached to a rotating part of the power tool may result in personal injury.
5. **Do not overreach. Keep proper footing and balance at all times.** This enables better control of the power tool in unexpected situations.
6. **Dress properly. Do not wear loose clothing or jewelry. Keep your hair and clothing away from moving parts.** Loose clothes, jewelry or long hair can be caught in moving parts.
7. **If devices are provided for the connection of dust extraction and collection facilities, ensure these are connected and properly used.** Use of dust collection can reduce dust-related hazards.
8. **Do not let familiarity gained from frequent use of tools allow you to become complacent and ignore tool safety principles.** A careless action can cause severe injury within a fraction of a second.

Power Tool Use and Care

1. **Do not force the power tool. Use the correct power tool for your application.** The correct power tool will do the job better and safer at the rate for which it was designed.
2. **Do not use the power tool if the switch does not turn it ON and OFF.** Any power tool that cannot be controlled with the switch is dangerous and must be repaired.
3. **Disconnect the plug from the power source and/or remove the BATTERY pack, if detachable, from the power tool before making any adjustments, changing accessories, or storing power tools.** Such preventive safety measures reduce the risk of starting the power tool accidentally.
4. **Store idle power tools out of the reach of children and do not allow persons unfamiliar with the power tool or these instructions to operate the power tool.** Power tools are dangerous in the hands of untrained users.
5. **Maintain power tools and accessories. Check for misalignment or binding of moving parts, breakage of parts and any other condition that may affect the power tool's operation. If damaged, have the power tool repaired before use.** Many accidents are caused by poorly maintained power tools.
6. **Keep cutting tools sharp and clean.** Properly maintained cutting tools with sharp cutting edges are less likely to bind and are easier to control.
7. **Use the power tool, accessories and tool bits etc. in accordance with these instructions, taking into account the working conditions and the work to be performed.** Use of the power tool for operations different from those intended could result in a hazardous situation.
8. **Keep handles and grasping surfaces dry, clean and free from oil and grease.** Slippery handles and grasping surfaces do not allow for safe handling and control of the tool in unexpected situations.

Service

1. **Have your power tool serviced by a qualified repair person using only identical replacement parts.** This will ensure that the safety of the power tool is maintained.

SPECIFIC SAFETY INFORMATION



WARNING

This section contains important safety information that is specific to this tool.

Read these precautions carefully before using this drain cleaning machine to reduce the risk of electrical shock or other serious injury.

SAVE ALL WARNINGS AND INSTRUCTIONS FOR FUTURE REFERENCE.

Keep this manual with machine for use by operator.

Drain Cleaning Machine Safety

1. **Before using the tool, test the ground fault circuit interrupter (GFCI) provided with the supply cord to insure it is operating correctly.** A properly operating GFCI reduces the risk of electrical shock.
2. **Only use extension cords that are protected by a GFCI.** The GFCI on the machine power cord will not prevent electrical shock from the extension cords.
3. **Only grasp the rotating cable with gloves recommended by the manufacturer.** Latex or loose fitting gloves or rags can become wrapped around the cable and may result in serious personal injury.
4. **Do not allow the cutter to stop turning while the cable is turning.** This can overstress the cable and may cause twisting, kinking or breaking of the cable and may result in serious personal injury.
5. **One person must control both the cable and the switch.** If the cutter stops rotating, the operator must be able to turn the tool off to prevent the cable from twisting, kinking and breaking.
6. **Use latex or rubber gloves inside the gloves recommended by the manufacturer, goggles, face shields, protective clothing, and respirator when chemicals, bacteria or other toxic or infectious substances are suspected to be in a drain line.** Drains may contain chemicals, bacteria and other substances that may cause burns, be toxic or infectious or may result in other serious personal injury.
7. **Practice good hygiene. Do not eat or smoke while handling or operating the tool. After handling or operating drain cleaning equipment, use hot, soapy water to wash hands and other body parts exposed to drain contents.** This will help reduce the risk of health hazards due to exposure to toxic or infectious material.
8. **Only use the drain cleaner for the recommended drain sizes.** Using the wrong size drain cleaner can lead to twisting, kinking or breaking of the cable and may result in personal injury.

Specific Safety Information for The Metro

1. **Only wear leather gloves.** Never use any other type of glove, such as cloth, rubber, or coated gloves. Never grasp a rotating cable with a rag. These items could become wrapped around the cable and cause injury.
2. **Do not overstress cables.** Keep a leather-gloved hand on the cable for control when machine is running. Overstressing the cables because of an obstruction may cause twisting, kinking, or breaking of the cable and may result in injury.
3. **Never operate the machine with the belt guard removed.** Fingers can get caught between belt and pulley.
4. **Never operate machine without Guide Tube in place.** Can result in significant hand injury.
5. **Place the machine at a distance not greater than two feet (.6m) from the drain opening.** Greater distances can result in cable twisting or kinking.
6. **Do not operate the machine in reverse (REV).** Operating machine in reverse can result in cable damage and is used only to back cutting tool out of obstruction.
7. **Keep hands away from rotating drum.** Do not reach into drum unless machine is unplugged. Hand may be cause in moving parts resulting in serious injury.
8. **Be careful when cleaning drains where cleaning chemicals have been used.** Avoid direct contact with skin and eyes. Drain cleaning chemicals can cause serious burns as well as damage the cable.
9. **Do not operate machine while standing in water.** Will increase risk of electric shock.
10. **Only use this tool in the application for which it was designed. Follow the instructions on the proper use of the machine.** Other uses or modifying the drain cleaner for other applications may increase risk of injury.
11. **Before starting each job, check that the cable in the drum is not broken or kinked by pulling the cable out and checking for wear or breakage.** Always replace worn (kinked or broken) cables with genuine GENERAL replacement cables.
12. **When servicing a tool, use only identical replacement parts. Follow instructions in the Maintenance section of this manual.** Use of unauthorized parts or failure to follow Maintenance instructions may create a risk of electric shock or injury.

Ground Fault Circuit Interrupter (GFCI)

Your machine is equipped with a ground fault circuit interrupter, which protects you against shock if a short circuit should occur. Check that receptacle is properly grounded. Test the GFCI before each use.

1. Plug into 120-volt receptacle.
2. Push test button. Indicator light will go out and power to machine should cut off.
3. If light does not go out when test button is pushed, **DO NOT USE THE MACHINE** until proper repairs can be made.
4. To restore power after test, push reset button. With the reset button depressed, if the machine doesn't start, stops while running, or if the operator experiences a mild shock, **DO NOT USE THE MACHINE!** Tag the machine out of service and take it to a motor repair center or return it to the factory for repairs.

! THE SECTION OF CORD BETWEEN THE WALL PLUG AND THE GFCI IS NOT IN THE PROTECTED CIRCUIT.

FEATURES

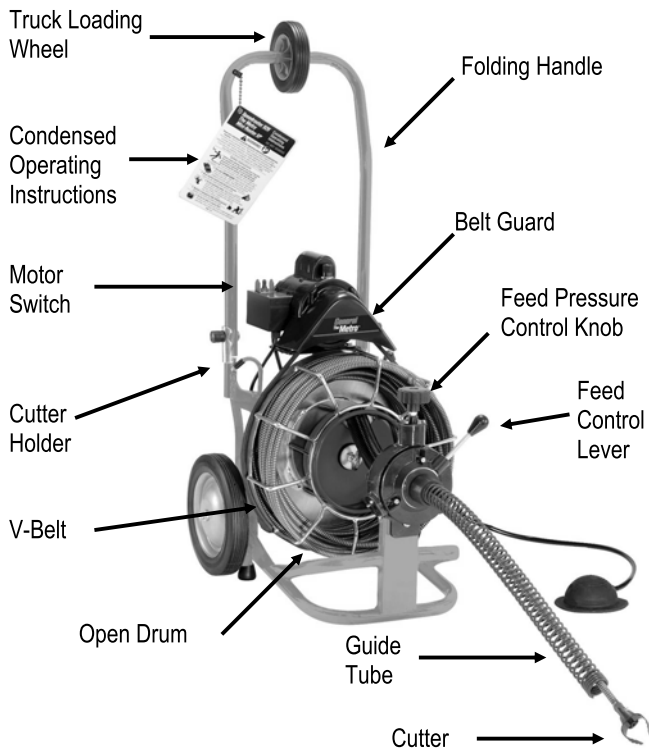

NOTE: Do not operate machine if warning labels on the switch box and power cord are missing or illegible.

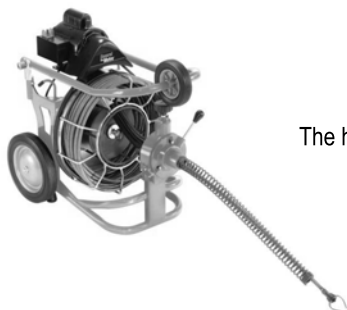

The handle folds for compact storage.

Cable Application Chart (Table 1)

Cable Size	Pipe Size	Typical Applications	Max. Capacity
9/16"	3" to 4"	Laundry Tubs, Roof Vents, Stacks (No roots)	100 ft.

Cutter Application Chart (Table 2)

Cutter	Cat. #	Typical Applications
Cutters for 9/16" Cables (Open Drum Metro)		
Arrow Head	AH	Starting tool, gets water flowing
1-1/2" U-Cutter	1-1/2UC	Starting tool, to remove loose objects.
2" U-Cutter	2UC	Starting tool, to remove loose objects.
Small Retrieving Tool	RTR-1	To remove loose objects and broken cables.

Note: There are no fixed rules for what cutter to use. If one tool doesn't take care of a stoppage, simply try another.

INSTALLING THE GUIDE TUBE HOLDER

1. To install the Guide Tube Holder on The Metro, follow the assembly shown in the diagram below. Place the Guide Tube Holder on the mounting knob, then thread it onto the bolt to secure the Power Cable Feed. (See diagram below.)

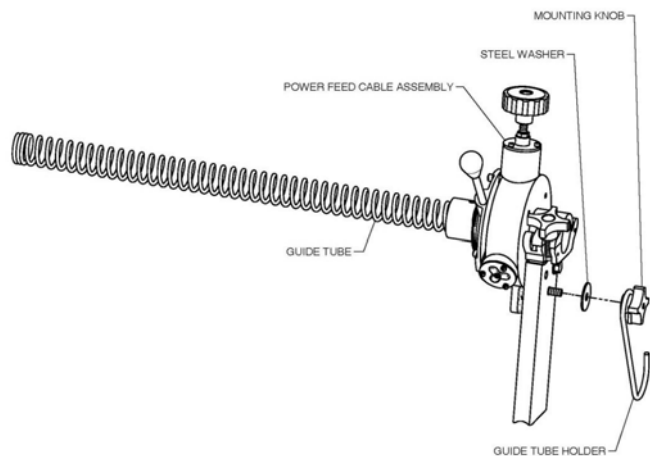

2. To secure the end of the Guide Tube, place it between the frame support tubes.
3. Bend the Guide Tube back into the Holder so that it catches a coil near the end of the Guide Tube. (See photo below.)



THE CABLE AND SPRING ARE UNDER TENSION WHEN ATTACHED TO THE HOLDER. USE CAUTION WHEN RELEASING THE GUIDE TUBE FROM THE HOLDER.

OPERATION

Set-Up



MAKE SURE THE MOTOR SWITCH IS IN THE 'OFF' POSITION!

1. Be sure the motor switch is in the **OFF** position.
2. Place machine within approximately two feet of drain opening. Be sure the Metro Guide Tube (ME-GT) is in place. If you can't place the machine this close to the drain opening, run the cable through the optional Guide Tube Extension (GTE) or a metal guide tube to prevent cable whipping. On manual feed machines, always keep a gloved hand on the cable.
3. Position the foot pedal for easy accessibility. The machine is designed for one-person operation. Be sure you can quickly remove your foot from the pedal in an emergency.
4. Make sure the Power Cable Feed is set to match the cable size you have selected. For use with a 9/16" cable, the feed should be assembled with the raised side of the caps inward.

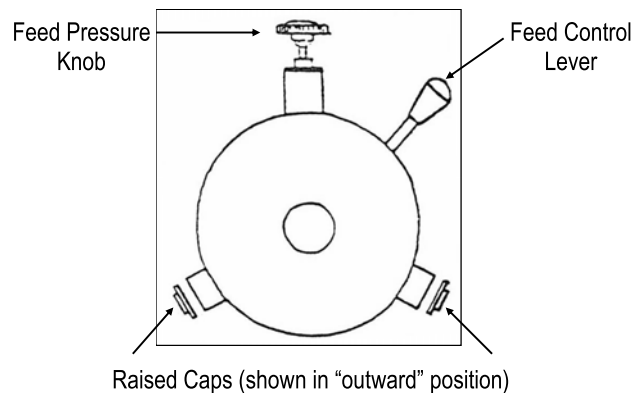

5. Select the proper cutting tool (See Cutter Application Chart—Table 2). A good tool to start with is the Arrow Head or 1-1/2 U-Cutter. After the line is opened, follow with larger blades, which scrape the inside edges of the pipe, assuring a real cleaning job.
6. Insert the cutter into the female connector at the front of the cable and tighten the connecting screw and lock washer *firmly* in place.



Operation

1. Before stepping on the foot pedal, pull cable from the drum and slide it into the drain as far as it will go.
2. Tighten the knob at the top of the Power Cable Feed so that the feed roller presses against the cable. Be sure not to over-tighten, since this could cause excess cable wear.
3. The feed lever controls the feeding rate and direction of the cable. Move the lever down to feed cable out of drum. The further the lever is moved downward, the faster the cable will feed out. Move lever up to retract cable into drum. When the lever is in the middle (neutral) position, cable will spin in place.

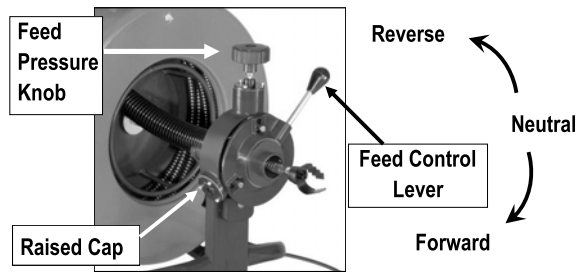

4. Move the motor switch to the **FORWARD** position.
5. With a leather-gloved hand on the Guide Tube or cable, depress the air foot pedal to start machine. Feed the cable into the line and against the obstruction with a firm, even pressure. Adjust the feeding rate to the resistance met. Do not force the cable—let the cutter do the work. The job won't go any faster and you could damage the cable.

**DO NOT USE TOO MUCH FORCE –
LET THE CUTTER DO THE WORK.**

6. Don't leave too much slack in the cable since this will cause whipping. If the cable starts to bend or build up too much twist, release pressure on the foot pedal and rotate the drum in the opposite direction to relieve the twist on the cable. Push any excess cable back into the drum and then continue.

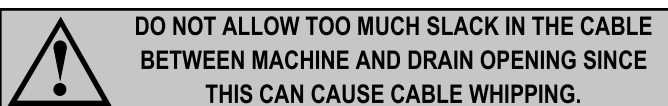

7. If you're having trouble getting around tight bends, try putting the machine in reverse while applying steady pressure. (If using Power Cable Feed, putting motor in reverse will cause the feed control lever to operate opposite of normal.)

Note: If your machine is equipped with a momentary contact reverse switch, you must hold the switch in position when operating the machine in reverse.

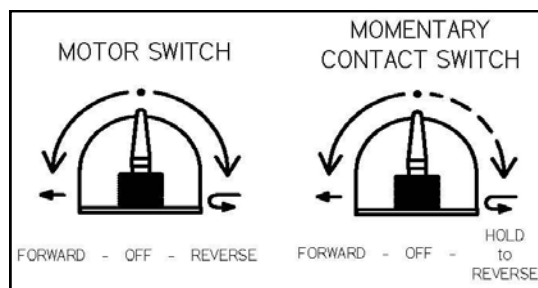

Don't do this for more than a few seconds at a time as this could cause tangling in the drum or kinking.

8. If you still can't get around the bend, you're probably using too large a cable. Switch to a smaller cable (See Cable Application Chart—Table 1), or use the optional flexible leader.
9. When cable reaches the stoppage, put feed into neutral. Then, allow the cable to progress forward slowly, chewing into the stoppage as it goes. This slow, forward movement will reduce stress on the cable while doing a more thorough cleaning job. A back and forth action often works best.

Hint: It's often helpful to have a small stream of water running in the line to wash the cuttings away while the machine is in operation and after.

10. Be careful not to let the cutter get caught in the stoppage as you work through it. This can cause kinking and breaking of the cable. When you feel the cable starting to twist in your hands, stop the machine and pull back. This will free the cutter from the obstruction. Then allow the cable to move forward slowly into the stoppage.
11. After the line has been cleared, return the cable to the drum with the motor turning **forward**. This is important to prevent the cable from tangling in the drum or in the line.
12. When the cutting tool is near the drain opening, take your foot off the pedal to stop drum rotation. Never retract the cutting tool from drain while cable is rotating. The cable could whip and cause serious injury.

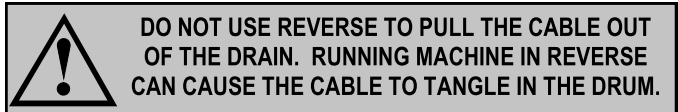

SPECIAL OPERATIONS

IF CABLE GETS CAUGHT IN LINE

The motor can be reversed to free the cable if it gets caught in line. (Note: if using Power Cable Feed, putting motor in reverse will cause the feed control lever to operate opposite of normal.)

1. Move motor switch to the reverse position.
2. Depress the foot pedal while retracting the cable.
3. After cable is loose, move switch back into forward position.

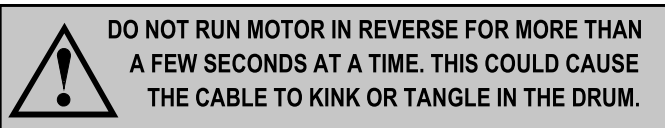

IF CABLE TANGLES IN DRUM

This is almost always caused by using too much pressure when feeding the cable, or by feeding the cable while running the machine in reverse. To untangle, rotate drum in opposite direction. This will usually get the cable to lie in the drum properly.

If cable has become badly tangled, which will not happen when machine is used properly, it may be necessary to pull the entire cable out of the drum and re-install it. (See "How to Install Cables In Drum" section.)

HOW TO INSTALL CABLES IN DRUM



1. Connect the male end of cable to the drum connecting cable already attached to drum.
2. Remove V-Belt
3. Be sure the cable goes into drum as shown in the diagram or cable will tangle in drum.
4. Replace V-Belt after cable is installed.

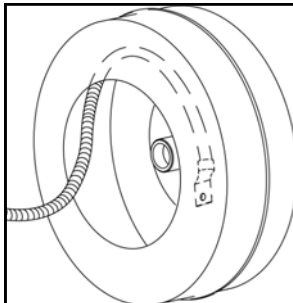

NOTE: The cable must lay in the drum in the correct direction or it will tangle in the drum.

MAINTENANCE



**DISCONNECT MACHINE FROM POWER SOURCE
BEFORE PERFORMING MAINTENANCE!**

To keep your machine operating smoothly, it is essential that all bearings be lubricated. Oiling moving parts is particularly important where machine comes in contact with sand, grit and other abrasive material.

CABLE MAINTENANCE

To get maximum service from your cables, be sure that they are clean and well oiled. This not only provides running lubrication but greatly extends the life of the cables as well. Some users periodically pour oil directly into the drum. Then, as the drum turns, the cables get complete lubrication. Our SNAKE OIL is ideally suited for this purpose, since it not only lubricates the cables, it deodorizes them as well.



FEED MAINTENANCE

Keep feed free of excessive soil and grit. It is recommended that the feed be flushed with fresh water followed by a light oiling of the moving parts. No disassembly is normally required. Failure to feed can usually be traced to the following possibilities:

DIRT ACCUMULATION

Over time, dirt can harden enough to stop roller rotation. Flushing with water followed by liberal oiling can usually restore function. If disassembly is required, proceed as follows:

1. Remove the feed pressure knob, cover screws, top cover, spring, ball bearing and ball bearing holder. Note the positioning of these parts to ease re-assembly. Remove the swing pin from the carrier. The top roller assembly can now be removed.
2. Remove the end cap screws, end caps and thrust washers from the bottom housing cylinders. Remove swing pins from carriers. The bottom roller assemblies can now be removed.
3. Re-assembly is done in reverse order.

DAMAGED ROLLER

Excessive use may wear a roller to the point of failure. It is recommended that all three rollers be replaced at the same time (Cat # PO-703). The replacement roller is an assembly consisting of one Feed Roller, two Feed Roller Bearings, and two Bearing Spacers.

Note: The Bearing Spacers must be installed between the Carrier and each Feed Roller Bearing (as illustrated below) in order to ensure proper operation and to obtain maximum Feed Roller life.

To Replace the Feed Roller Assembly:

1. Remove the Feed Roller Assembly by unscrewing and removing the Feed Roller Axle.
2. For convenience, the components are assembled and wired together at the factory. Before attempting to install the assembly, hold the assembly together and remove the wire.
3. While still holding the Feed Roller Assembly together, insert it into the slot opening of the Carrier.

4. In order to help align the Spacers and Bearings, insert a pencil point or similar object through the **un-threaded** end of the Axle hole in the Carrier. After removing the pencil point, continue to maintain the alignment of the components.
5. The Feed Roller Axle should then be inserted through the same un-threaded Axle hole and should continue to be guided through the Spacers and Bearings to the threaded Axle hole on the other side of the Carrier.
6. Securely tighten the Axle to the Carrier with a 3/16" allen wrench.

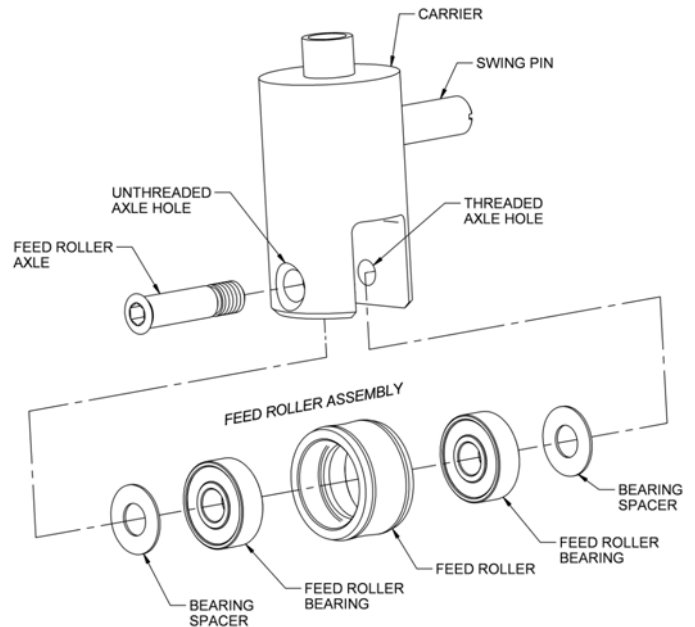

TANGLED CABLE

If a cable loops over itself in the drum, it will not feed properly. Remove and reload the cable to restore function. If the cable kinks, it is evidence of abuse and results from the use of too much pressure or use of the wrong size cable for the line. Do not force the cable — let the cutter do the work.

TROUBLE SHOOTING GUIDE

Problem	Probable Cause	Solution
Cable kinks, tangles or breaks.	Operator forcing the cable.	Do not force cable! Let the cutter do the work.
	Too much slack between machine and drain.	Allow a distance of no more than two feet between machine and drain.
	Cable used in wrong size drain line.	A cable that is too large or too small in diameter for a line is more likely to kink. (Consult Cable Application Chart – Table 1.)
	Cable exposed to acid.	Clean and oil cables routinely.
Drum stops while pedal is depressed.	Hole in pedal or hose.	Replace damaged component.
	Hole in diaphragm switch.	If no problem found with the pedal or hose, replace the diaphragm switch.
	Thermal overload activated.	Allow motor to cool. Press reset button.
Drum turns in one direction but not the other.	Faulty reverse switch or faulty momentary contact switch.	Replace switch. Note: Momentary contact switch must be held in position to use reverse.
Ground Fault Interrupter trips and will not reset.	Damaged power cord or extension cord.	Replace cords.
	Excess moisture in area.	Remove excess moisture from area.
	Short circuit in motor.	Take motor to authorized service center. (Call General for details.)
	Faulty Ground Fault Interrupter.	Replace Ground Fault Interrupter.
Failure to feed.	Cable tangled in drum.	Do not run machine in reverse. Use proper cable size. (Consult Cable Application Chart – Table 1.)
	Feed rollers frozen.	Clean and lubricate feed rollers regularly. Replace worn rollers.
	Worn cable.	When cable coils wear flat, cable should be replaced.
Motor turns but drum does not.	Slip clutch is slipping because cable is being forced.	Do not force cable. Do not allow too much slack between the cable and the machine.
	Slip clutch is worn.	Replace slip clutch.

General Wire Spring Co.
1101 Thompson Avenue
McKees Rocks, PA 15136
412-771-6300 www.drainbrain.com