

For more information, visit [www.desatech.com](http://www.desatech.com)

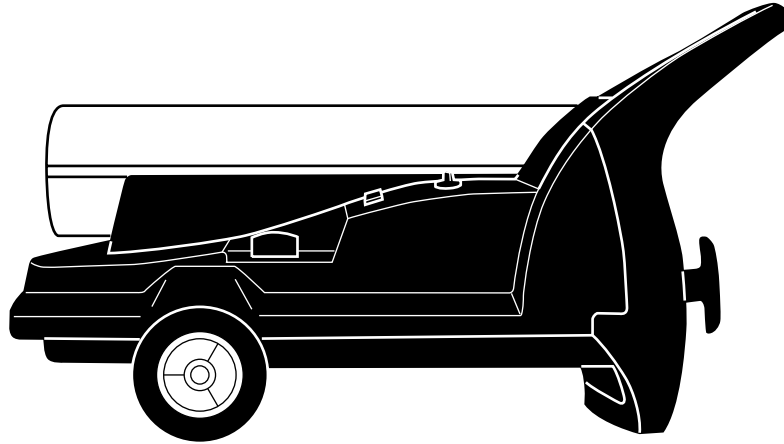

**Heater Sizes:**  
**125,000 170,000 and 200,000 Btu/Hr**  
**Kerosene/Diesel Heater with Built-in Thermostat**

**IMPORTANT:** Read and understand this manual before assembling, starting or servicing heater. Improper use of heater can cause serious injury. Keep this manual for future reference.

## TABLE OF CONTENTS

SAFETY INFORMATION .....	2	TROUBLESHOOTING .....	7
PRODUCT IDENTIFICATION .....	3	SERVICE PROCEDURES .....	8
UNPACKING .....	3	SPECIFICATIONS .....	13
FUELS .....	3	ILLUSTRATED PARTS BREAKDOWN AND PARTS LIST .....	14
VENTILATION .....	3	WHEELS AND HANDLE .....	18
THEORY OF OPERATION .....	4	TECHNICAL SERVICE .....	19
ASSEMBLY .....	4	REPLACEMENT PARTS .....	19
OPERATION .....	5	WIRING DIAGRAM .....	19
OPERATION WITH PORTABLE GENERATOR .....	5	ACCESSORIES .....	19
STORING, TRANSPORTING, OR SHIPPING .....	5	OWNER'S REGISTRATION CARD .....	21
PREVENTATIVE MAINTENANCE SCHEDULE .....	6	WARRANTY AND REPAIR SERVICE .....	Back Cover

**Fill In For Your Records**

Model No. \_\_\_\_\_  
 (Located on side panel)

Serial No. \_\_\_\_\_  
 (Located on fuel tank)

Date of Purchase: \_\_\_\_\_



## SAFETY INFORMATION

### WARNINGS

**IMPORTANT:** Read this owner's manual carefully and completely before trying to assemble, operate, or service this heater. Improper use of this heater can cause serious injury or death from burns, fire, explosion, electrical shock, and carbon monoxide poisoning.

** DANGER:** Carbon monoxide poisoning may lead to death!

**Carbon Monoxide Poisoning:** Early signs of carbon monoxide poisoning resemble the flu, with headaches, dizziness, and/or nausea. If you have these signs, the heater may not be working properly. **Get fresh air at once!** Have heater serviced. Some people are more affected by carbon monoxide than others. These include pregnant women, persons with heart or lung disease or anemia, those under the influence of alcohol, and those at high altitudes.

Make certain you read and understand all warnings. Keep this manual for reference. It is your guide to safe and proper operation of this heater.

- Use only kerosene, #1/#2 diesel/fuel oil, JET A or JP-8 fuels to avoid risk of fire or explosion. Never use gasoline, naphtha, paint thinners, alcohol, or other highly flammable fuels.
- Fueling
  - a) Personnel involved with fueling shall be qualified and thoroughly familiar with the manufacturer's instructions and applicable regulations regarding the safe fueling of heating units.
  - b) Only the type of fuel specified on the heater's data plate shall be used.
  - c) All flame, including the pilot light, if any, shall be extinguished and the heater allowed to cool, prior to fueling.
  - d) During fueling, all fuel lines and fuel-line connections shall be inspected for leaks. Any leaks shall be repaired prior to returning the heater to service.
  - e) At no time shall more than one day's supply of heater fuel be stored inside a building in the vicinity of the heater. Bulk fuel storage shall be outside the structure.
  - f) All fuel storage shall be located a minimum of 762cm (25 feet) from heaters, torches, welding equipment, and similar sources of ignition (exception: the fuel reservoir integral with the heater unit).
  - g) Whenever possible, fuel storage shall be confined to areas where floor penetrations do not permit fuel to drip onto or be ignited by a fire at lower elevation.
  - h) Fuel storage shall be in accordance with the authority having jurisdiction.
- Use only the electrical voltage and frequency specified on model plate.
- Heater must be grounded. Use only a properly grounded three-wire extension cord. Plug into grounded outlet only.
- Use only in areas free of flammable vapors or high dust content.
- Minimum clearance from any combustible materials: 8 feet (244 cm) from hot air outlet; 6 feet (183 cm) from top; and 2 feet (61 cm) from sides and inlet.
- Locate heater on a stable and level surface while hot or operating or a fire may occur.
- Use only in well-vented areas. Before using heater, provide at least a 2800 square cm (three-square-foot) opening of fresh, outside air for each 30 kw (100,000 Btu/Hr) of rating. This heater produces carbon monoxide, which is listed by the State of California as a reproductive toxin under Proposition 65.
- Keep children and animals away from heater at all times.
- Never start heater when combustion chamber is hot or if fuel has accumulated in combustion chamber.
- When used with thermostat, heater may start at anytime.
- When heater is moved or stored, it must be in a level position or fuel spillage may occur.
- Use heater only in accordance with local ordinances and codes.
- Never use gasoline, crankcase drainings, naphtha, paint thinners, alcohol, or other highly flammable fuels.
- Never use heater where gasoline, paint thinner, or other highly flammable vapors are present.
- Never use heater in living or sleeping areas.
- Never leave a heater plugged in without adult supervision if children or animals are likely to be present.
- Never move, handle, refuel, or service a hot, operating, or plugged-in heater.
- Never attach duct work to front or rear of heater.
- Never attach heater to external fuel tank.
- Heaters used in the vicinity of tarpaulins, canvas, or similar enclosure materials shall be located a safe distance from such materials. The recommended minimum safe distance is 304.8cm (10 feet). It is further recommended that these enclosure materials be of a fire retardant nature. These enclosure materials shall be securely fastened to prevent them from igniting or from upsetting the heater due to wind action.
- Unplug heater when not in use.
- Never block air inlet (rear) or air outlet (front) of heater.
- **Warning to New York City Residents**  
**For Use Only At Construction Sites** in accordance with applicable NYC codes under NYCFD certificate of approval #4803, #4899, #4908, #4909, or #4934.

## PRODUCT IDENTIFICATION

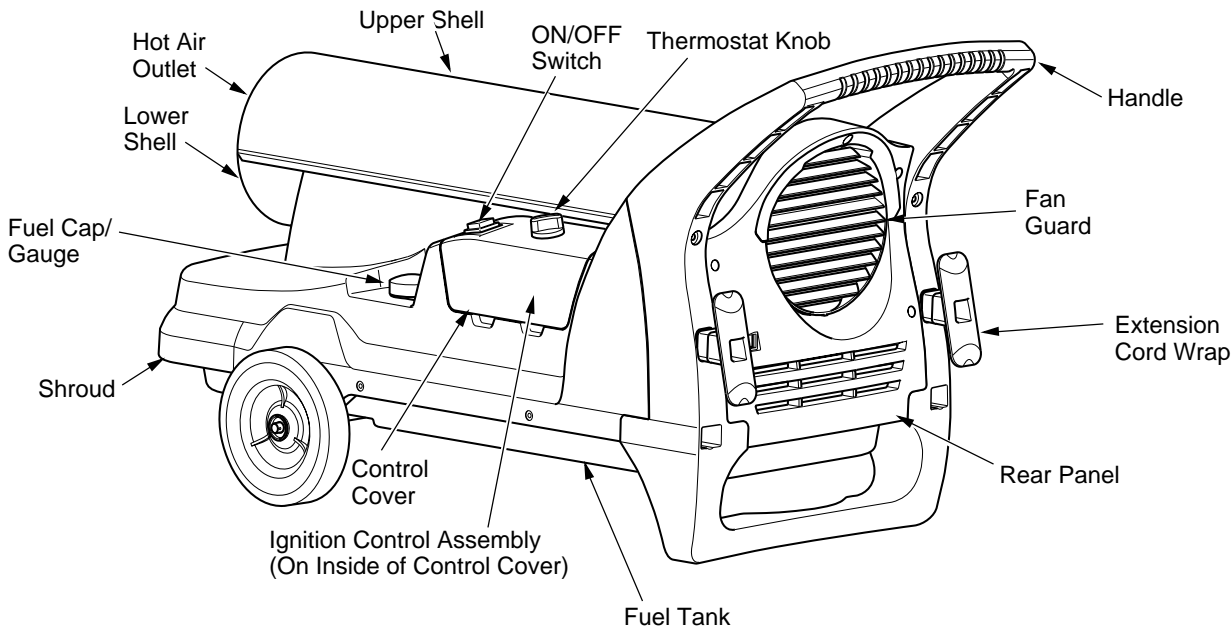

Figure 1 - 125T, 170T and 200T Models

## UNPACKING

1. Remove all packing items applied to heater for shipment.
2. Remove all items from carton.
3. Check items for any shipping damage. If heater is damaged, promptly inform dealer where you bought heater.

## FUELS

**⚠ WARNING:** Use only kerosene, #1/#2 diesel/fuel oil, JET A or JP-8 fuels to avoid risk of fire or explosion. Never use gasoline, oil drained from crankcases, naphtha, paint thinners, alcohol or other highly flammable fuels.

Use only kerosene, #1/#2 diesel/fuel oil, JET A or JP-8 fuels. Heavier fuels such as No. 2 fuel oil or No. 2 diesel fuel may also be used but will result in:

- noticeable odor
- additional fuel filter maintenance
- the need for nontoxic, anti-icer additives in very cold weather

Do not use fuels heavier than No. 2 grade or heavy oils such as oil drained from crankcases. These heavy oils will not ignite properly and will contaminate the heater.

**IMPORTANT:** Use a KEROSENE ONLY (blue) or DIESEL ONLY (yellow) storage container. Be sure storage container is clean. Foreign matter such as rust, dirt, or water will cause the ignition control assembly to shut down heater. Foreign matter may also require heater's fuel system to be frequently cleaned.

## VENTILATION

**⚠ WARNING:** Provide a fresh air opening of at least three square feet (2,800 square cm) for each 100,000 BTU/HR rating. Provide extra fresh air if more heaters are being used. The minimum ventilation requirements must be followed to avoid risks associated with carbon monoxide poisoning. Make certain these requirements are met prior to operating heater.

*Example:* A 58.6kw (200,000 Btu/Hr) heater requires one of the following:

- a two-car garage door [4.88 meter (16 feet) opening] raised 12.7 cm (5 inches)
- a single-car garage door [2.74 meter (9 feet) opening] raised 20.3 cm (8 inches)
- two, 76.2 cm (30 inch) windows raised 38.1 cm (15 inches)

## THEORY OF OPERATION

**The Fuel System:** The air pump forces air through the air line. The air is then pushed through the nozzle. This air causes fuel to be lifted from the tank. A fine mist of fuel is sprayed into the combustion chamber.

**The Air System:** The motor turns the fan. The fan pushes air into and around the combustion chamber. This air is heated and provides a stream of clean, hot air.

**The Ignition System:** The ignition control assembly provides power to the ignitor. This ignites the fuel/air mixture in the combustion chamber.

**The Flame-Out Control System:** This system causes the heater to shut down if the flame goes out.

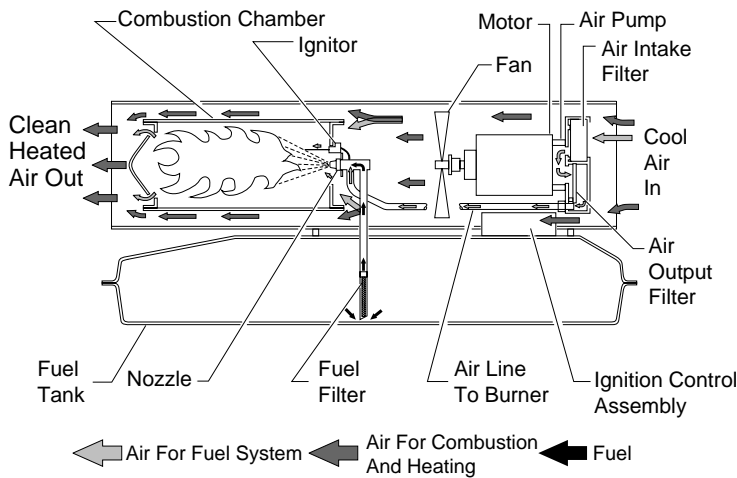

Figure 2 - Cross Section Operational View

## ASSEMBLY

These models are furnished with wheels and a rear handle. Wheels, handle, and the mounting hardware are found in the shipping carton.

### Tools Needed

- Medium Phillips Screwdriver
- Hammer
- Flat Blade Screwdriver

1. Slide axle through shroud. Install washers and wheels on axle as shown in Figure 3.

**IMPORTANT:** When installing wheels, point extended hub of wheels toward shroud (see Figure 3).

2. Place cap nuts on axle ends. Gently tap with hammer to secure.
3. Install extension cord wraps into handle.
4. Slide handle onto shroud leaving a one inch gap between parts.
5. Place washers onto screws and insert screws into holes in handles.
6. Visually confirm that all six screws are threaded into nuts in the shroud. Push the handle completely into the shroud.
7. Tighten all screws.

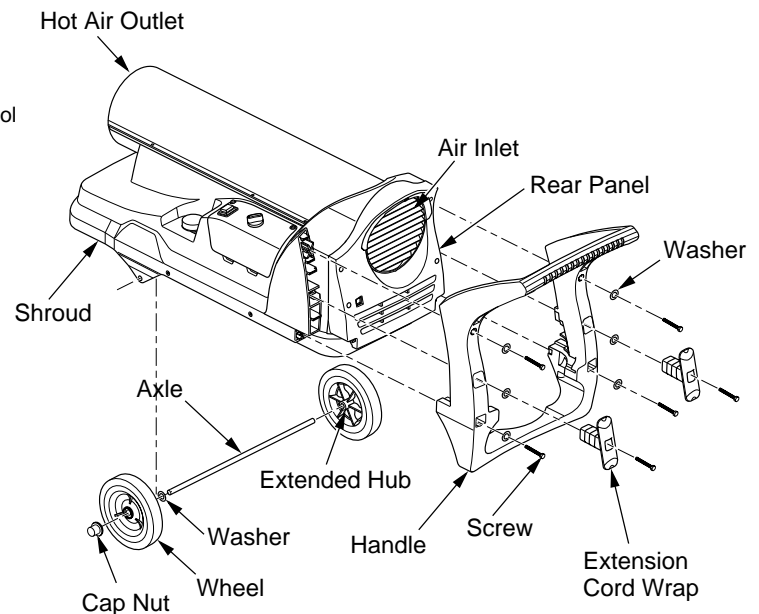

Figure 3 - Wheel and Handle Assembly

## OPERATION

**IMPORTANT:** Review and understand the warnings in the *Safety Information* section, page 2. They are needed to safely operate this heater. Follow all local ordinances and codes when using this heater.

### TO START HEATER

1. Follow all ventilation and safety information.
2. Locate heater to provide maximum circulation of the heated air. Follow all location requirements noted in *Safety Information*, page 2.
3. Fill fuel tank with fuel. Use only kerosene, #1/#2 diesel/fuel oil, JET A or JP-8 fuels to avoid risk of fire or explosion. Never use gasoline, naphtha, paint thinners, alcohol, or other flammable fuels.
4. Attach fuel cap/gauge.
5. Plug heater's power cord into approved, grounded, three-wire extension cord. Extension cord must be at least six feet (1.8 meters) long.

#### Extension Cord Size Requirement

6 to 10 feet (1.8 to 3 meters) long, use 18 AWG (0.75 mm<sup>2</sup>) rated cord

11 to 100 feet (3.3 to 30.5 meters) long, use 16 AWG (1.0 mm<sup>2</sup>) rated cord

101 to 200 feet (30.8 to 61 meters) long, use 14 AWG (1.5 mm<sup>2</sup>) rated cord

6. Plug extension cord into standard 120 volt/60 hertz, 3-prong grounded outlet.
7. Turn thermostat knob to the right (clockwise) to the warmest position.
8. Push ON/OFF switch to the ON (I) position. Light will come on. *Note:* Ignitor will preheat for five seconds, then heater will start.
9. After heater is running, adjust thermostat knob to the desired setting. *Note:* A cold heater may affect the thermostat setting. This thermostat is a general-heating control. It is not intended for precise temperature control. Adjust thermostat until heater cycles at the desired setting.

### TO STOP HEATER

Push ON/OFF switch to the OFF (O) position.

### TO RESET HEATER

1. Push ON/OFF switch to the OFF (O) position and wait 10 seconds. (Wait two minutes if heater has been running.)
2. Repeat steps under *To Start Heater*.

## OPERATION WITH PORTABLE GENERATOR

**⚠ WARNING:** Before operating heater or any appliance from a portable generator, verify that generator has been properly connected to earth ground. Improper grounding or failure to ground generator can result in electrocution if a ground fault occurs. Refer to owner's manual supplied by generator manufacturer for proper grounding procedures.

The operating voltage range of the heater is 108 to 132 Volts (120 Volts +/- 10%). Prior to plugging heater into generator the output voltage should be verified (if generator is equipped with the automatic idle feature, the output voltage should be measured with the generator running at full speed). If the voltage does not measure in this range the heater should not be plugged into the generator.

Refer to *Operation* for starting, stopping, and resetting heater procedures.

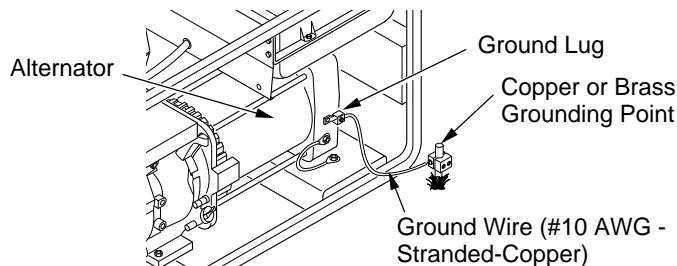

**Figure 4 - Typical Generator Grounding Method (Generator construction may vary from that shown)**

## STORING, TRANSPORTING, OR SHIPPING

*Note:* If shipping, transport companies require fuel tanks to be empty.

1. Remove drain plug from bottom side of fuel tank and drain all fuel.
2. Replace drain plug.
3. If any debris is noted in old fuel, add 1 or 2 quarts of clean kerosene to tank, stir, and drain again. This will prevent excess debris from clogging filters during future use.
4. Properly dispose of old and dirty fuel. Check with local automotive service stations that recycle oil.
5. If storing, store heater in dry place. Make sure storage place is free of dust and corrosive fumes.

**IMPORTANT:** Do not store kerosene over summer months for use during next heating season. Using old fuel could damage heater.

## PREVENTATIVE MAINTENANCE SCHEDULE

**⚠ WARNING:** Never service heater while it is plugged in, operating, or hot. Severe burns and electrical shock can occur.

Item	How Often	How To
Fuel tank	Flush every 150-200 hours of operation or as needed	See <i>Storing, Transporting, or Shipping</i> , page 5
Air output and lint filters	Replace every 500 hours of operation or once a year	See <i>Air Output, Air Intake, and Lint Filters</i> , page 8
Air intake filter	Wash and dry with soap and water every 500 hours of operation or as needed	See <i>Air Output, Air Intake, and Lint Filters</i> , page 8
Fuel filter	Clean twice a heating season or as needed	See <i>Fuel Filter</i> , page 9
Ignitor	No maintenance required	
Fan blades	Clean every season or as needed	See <i>Fan</i> , page 8
Motor	Not required/permanently lubricated	

## TROUBLESHOOTING

**⚠ WARNING: Never service heater while it is plugged in, operating, or hot. Severe burns and electrical shock can occur.**

FAULT CONDITION	POSSIBLE CAUSE	REMEDY
Motor does not start five seconds after heater is plugged in	<ol style="list-style-type: none"> <li>1. No power to heater</li> <li>2. ON/OFF switch not in the ON (I) position</li> <li>3. Thermostat setting is too low</li> </ol>	<ol style="list-style-type: none"> <li>1. Check circuit breaker in electrical panel</li> <li>2. Verify the ON/OFF switch is in ON (I) position and light is on</li> <li>3. Turn thermostat knob to a higher setting</li> </ol>
<b>⚠ WARNING: High voltage!</b>		
	<ol style="list-style-type: none"> <li>4. Bad electrical connection between motor and ignition control assembly or ignition control assembly and power cord</li> <li>5. Binding pump rotor</li> <li>6. Blown fuse (GMA 10A) on ignition control assembly</li> <li>7. Defective ignition control assembly</li> <li>8. Defective motor</li> </ol>	<ol style="list-style-type: none"> <li>4. Check all electrical connections. See <i>Wiring Diagram</i>, page 19</li> <li>5. If fan does not turn freely, see <i>Pump Rotor</i>, pages 12 and 13</li> <li>6. See <i>Ignition Control Assembly</i>, page 13</li> <li>7. Replace ignition control assembly</li> <li>8. Replace motor</li> </ol>
Motor starts and runs but heater does not ignite	<ol style="list-style-type: none"> <li>1. No fuel in tank</li> <li>2. Pump pressure incorrect</li> <li>3. Dirty fuel filter</li> <li>4. Obstruction in nozzle</li> <li>5. Water in fuel tank</li> </ol>	<ol style="list-style-type: none"> <li>1. Fill tank with kerosene</li> <li>2. See <i>Pump Pressure Adjustment</i>, page 9</li> <li>3. See <i>Fuel Filter</i>, page 9</li> <li>4. See <i>Nozzle Assembly</i>, pages 11 and 12</li> <li>5. Drain and flush fuel tank with clean kerosene. See <i>Storing, Transporting, or Shipping</i>, page 5</li> </ol>
<b>⚠ WARNING: High voltage!</b>		
	<ol style="list-style-type: none"> <li>6. Bad electrical connection between ignitor and ignition control assembly</li> <li>7. Defective ignitor</li> <li>8. Defective ignition control assembly</li> </ol>	<ol style="list-style-type: none"> <li>6. Check electrical connections. See <i>Wiring Diagram</i>, page 19</li> <li>7. Replace ignitor, see page 10</li> <li>8. Replace ignition control assembly</li> </ol>
Heater ignites but ignition control assembly shuts heater off after a short period of time	<ol style="list-style-type: none"> <li>1. Pump pressure incorrect</li> <li>2. Dirty air intake, air output, and/or lint filter</li> <li>3. Dirty fuel filter</li> <li>4. Obstruction in nozzle</li> <li>5. Photocell assembly not properly installed (not seeing the flame)</li> <li>6. Dirty photocell lens</li> </ol>	<ol style="list-style-type: none"> <li>1. See <i>Pump Pressure Adjustment</i>, page 9</li> <li>2. See <i>Air Output, Air Intake, and Lint Filters</i>, page 8</li> <li>3. See <i>Fuel Filter</i>, page 9</li> <li>4. See <i>Nozzle Assembly</i>, pages 11 and 12</li> <li>5. Make sure photocell boot is properly seated in bracket</li> <li>6. Clean photocell lens</li> </ol>
<b>⚠ WARNING: High voltage!</b>		
	<ol style="list-style-type: none"> <li>7. Bad electrical connection between photocell and ignition control assembly</li> <li>8. Defective photocell</li> <li>9. Defective ignition control assembly</li> </ol>	<ol style="list-style-type: none"> <li>7. Check electrical connections. See <i>Wiring Diagram</i>, page 19</li> <li>8. Replace photocell</li> <li>9. Replace ignition control assembly</li> </ol>

## SERVICE PROCEDURES

**⚠ WARNING:** To avoid risk of burn and electrical shock, never attempt to service heater while it is plugged in, operating, or hot.

### UPPER SHELL REMOVAL

1. Remove screws along each side of heater using phillips screwdriver. These screws attach upper and lower shells together. See Figure 5.
2. Lift upper shell off.
3. Remove fan guard.

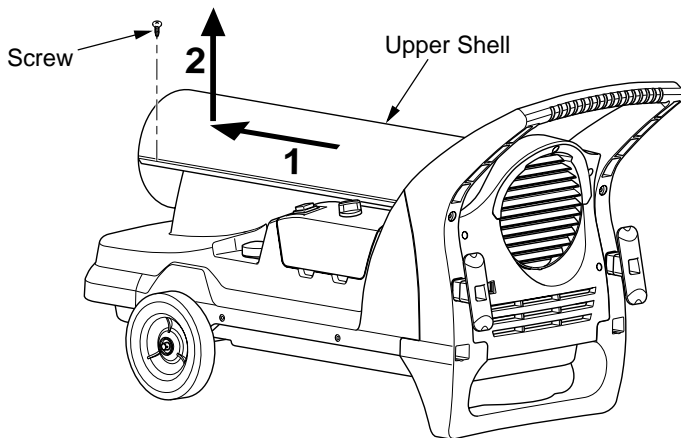

Figure 5 - Upper Shell Removal

### FAN

**IMPORTANT:** Remove fan from motor shaft before removing motor from heater. The weight of the motor resting on the fan could damage the fan pitch (see Figure 6).

1. Remove upper shell (see Figure 5).
2. Use 1/8" allen wrench to loosen setscrew which holds fan to motor shaft.
3. Slip fan off motor shaft.
4. Clean fan using a soft cloth moistened with kerosene or solvent.
5. Dry fan thoroughly.
6. Replace fan on motor shaft. Place fan hub flush with end of motor shaft (see Figure 7).
7. Place setscrew on flat of shaft. Tighten setscrew firmly (40-50 inch-pounds/4.5-5.6 n-m).
8. Replace upper shell.

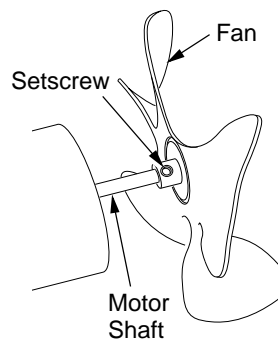

Figure 6 - Fan, Motor Shaft, and Setscrew Location

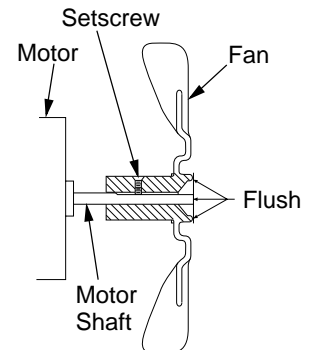

Figure 7 - Fan Cross Section and Setscrew Location

### AIR OUTPUT, AIR INTAKE AND LINT FILTERS

1. Remove upper shell (see Figure 5).
2. Remove filter end cover screws using 5/16" nut-driver (see Figure 8).
3. Remove filter end cover.
4. Replace air output and lint filters.
5. Wash or replace air intake filter (see *Preventative Maintenance Schedule*, page 6).
6. Replace filter end cover.
7. Replace upper shell.

**IMPORTANT:** Do not oil filters.

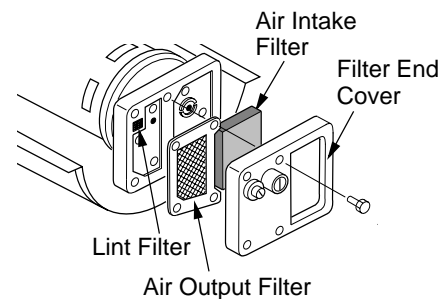

Figure 8 - Air Output, Air Intake, and Lint Filters



## SERVICE PROCEDURES

*Continued*

### PUMP PRESSURE ADJUSTMENT

1. Remove fan guard using medium phillips screwdriver.
2. Remove pressure gauge plug from filter end cover (see Figure 9).
3. Install accessory pressure gauge (part number HA1180).
4. Start heater (see *Operation*, page 5). Allow motor to reach full speed.
5. Adjust pressure. Turn relief valve to right to increase pressure. Turn relief valve to left to decrease pressure. See specifications below for correct pressure (see Figure 10).
6. Remove pressure gauge. Replace pressure gauge plug in filter end cover.

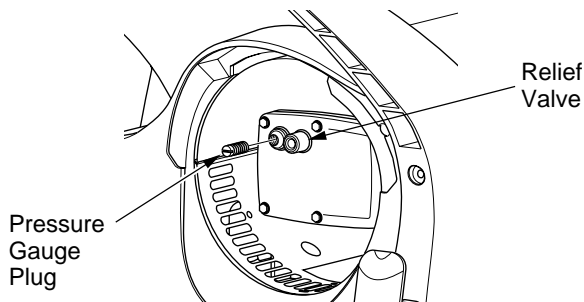

**Figure 9 - Pressure Gauge Plug Removal**

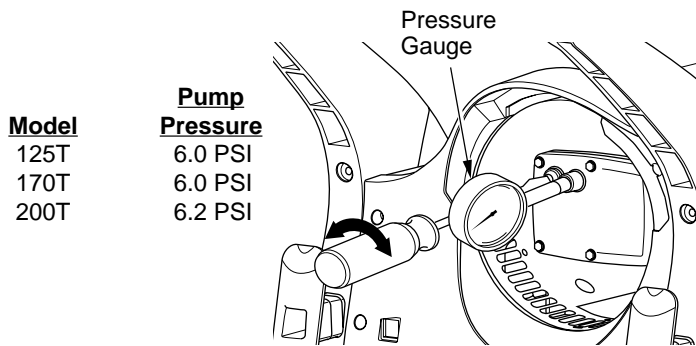

**Figure 10 - Adjusting Pump Pressure**

### FUEL FILTER

1. Remove control cover screws using medium phillips screwdriver.
2. Remove control cover.
3. Pull upper fuel line off fuel filter neck (see Figure 11).
4. Carefully pry bushing, fuel filter, and lower fuel line out of fuel tank (see Figure 11).
5. Wash fuel filter with clean fuel and replace in tank.
6. Attach upper fuel line to fuel filter neck.
7. Replace control cover.

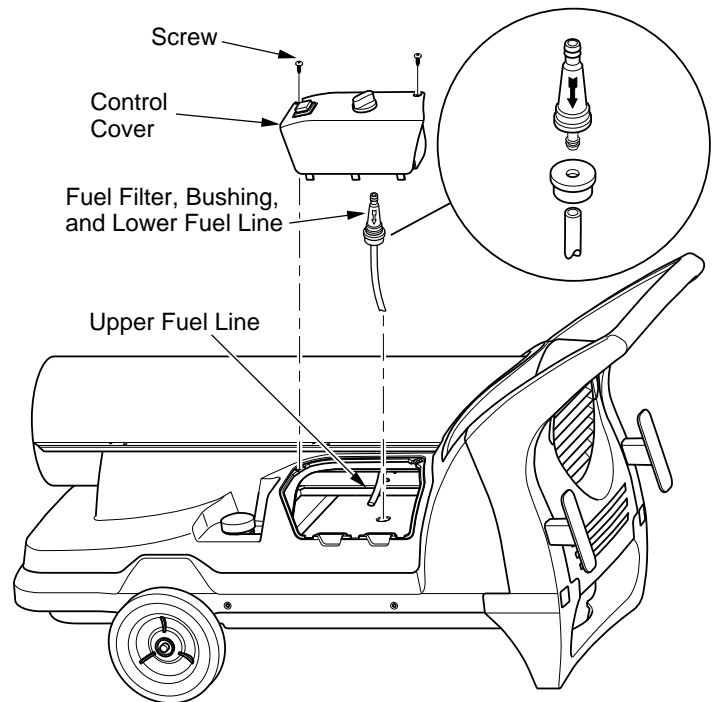

**Figure 11 - Fuel Filter Removal**

## SERVICE PROCEDURES

*Continued*

### IGNITOR

1. Remove upper shell (See *Upper Shell Removal*, page 8).
2. Remove fan (see page 8).
3. Remove 2 control cover screws with a phillips screwdriver. Remove control cover (see Figure 11, page 9).
4. Disconnect ignitor wires from ignition control assembly (see Figure 12). Pull the ignitor wires up through the hole in the lower shell.
5. Disconnect fuel line hose and air line hose. Remove photocell from photocell bracket (see Figure 12).
6. Remove combustion chamber. Stand combustion chamber on end with nozzle adapter bracket on top (see Figure 13).
7. Remove ignitor screw with a 1/4" nut driver. Carefully remove ignitor from nozzle adapter bracket.
8. Carefully remove replacement ignitor from styrofoam packing.
9. Carefully guide ignitor into opening in nozzle adapter bracket. Do not strike ignitor element. Attach ignitor to nozzle adapter bracket with screw using a 1/4" nut driver (see Figure 13). Torque .90 to 1.69 N-m (8 to 15 in-lbs) Do not over torque.
10. Replace combustion chamber.
11. Route the ignitor wires back down through the hole in the lower shell. Connect wires to the ignition control assembly (see Figure 12).
12. Replace control cover (see Figure 11, page 9).
13. Connect and route fuel line hose and air line hose to nozzle adapter assembly. See *Fuel and Air Line Replacement and Proper Routing*, page 12.
14. Replace photocell in photocell bracket. Route wires as shown in either Figure 14, page 11.
15. Replace fan (see page 8).
16. Replace upper shell (see page 8).

**⚠ CAUTION: Do not bend or strike ignitor element. Handle with care.**

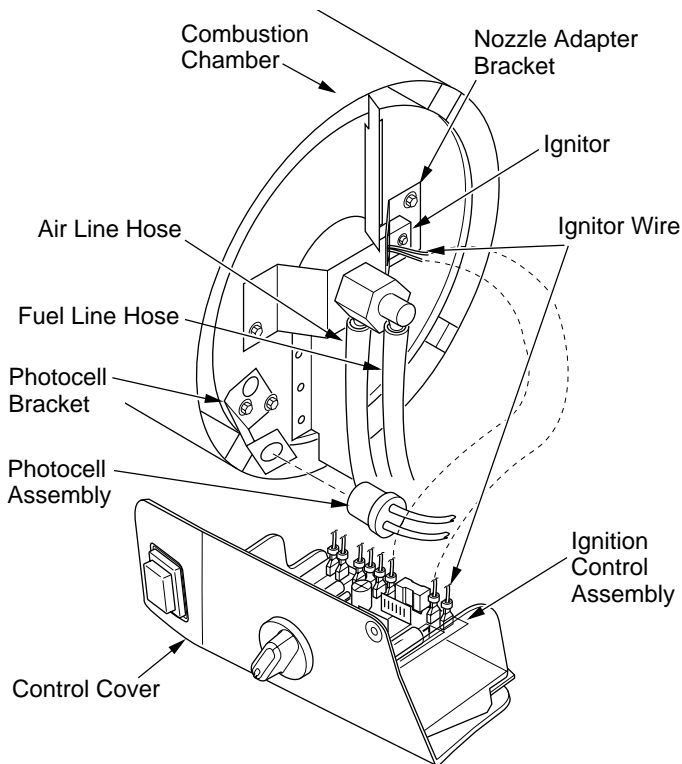

**Figure 12 - Disconnecting Ignitor Wires from Ignition Control Assembly (125T, 170T Model Shown)**

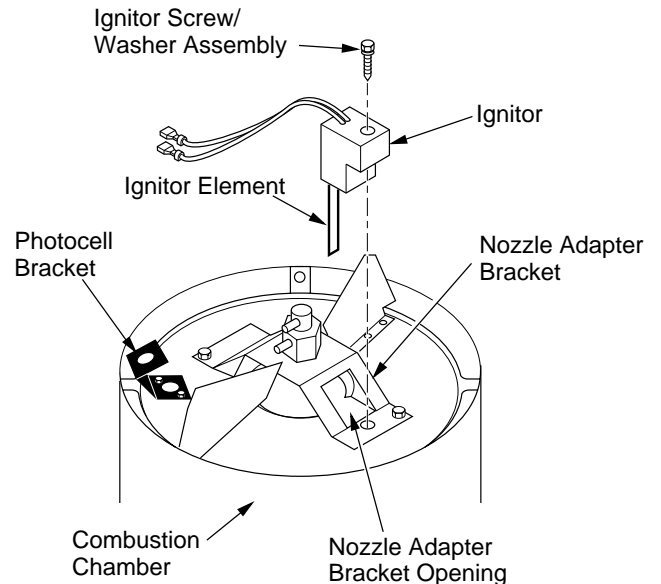

**Figure 13 - Ignitor Replacement (125T, 170T Model Shown)**

## SERVICE PROCEDURES

*Continued*

### NOZZLE ASSEMBLY

#### 125T and 170T Models Only

1. Remove upper shell (see *Upper Shell Removal*, page 8).
2. Remove fan (see *Fan*, page 8).
3. Remove fuel and air line hoses from nozzle assembly (see Figure 14).
4. Turn nozzle assembly 1/4 turn to left and pull toward motor to remove (see Figure 15).
5. Place plastic hex-body into vise and lightly tighten.
6. Carefully remove nozzle from the nozzle adapter using 5/8" socket wrench (see Figure 16).
7. Blow compressed air through face of nozzle. This will free any dirt in nozzle area.
8. Inspect nozzle sleeve for damage.
9. Replace nozzle into nozzle adapter until nozzle seats. Tighten 1/3 turn more using 5/8" socket wrench 4.5 to 5.1 N-m (40 to 45 in-lbs). See Figure 16.
10. Attach nozzle assembly to nozzle adapter bracket (see Figure 15).
11. Attach fuel and airline hoses to nozzle assembly. See *Fuel and Airline Replacement and Proper Routing*, page 12.
12. Replace fan (see *Fan*, page 8).
13. Replace upper shell (see *Upper Shell Removal*, page 8).

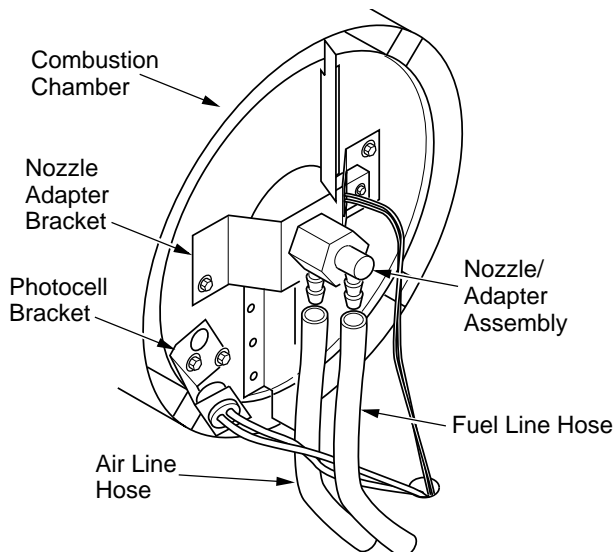

**Figure 14 - Removing Air and Fuel Line Hoses (125T and 170T Models Only)**

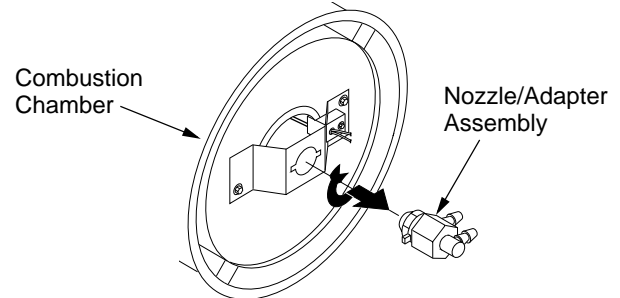

**Figure 15 - Removing Nozzle/Adapter Assembly**

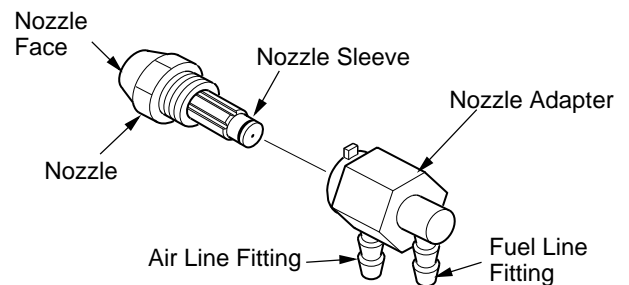

**Figure 16 - Nozzle and Nozzle Adapter**

#### 200T Model Only

1. Remove combustion chamber and ignitor by following steps 1 through 7 under *Ignitor*, page 10.
2. Carefully place the ignitor in a safe location.
3. Remove two nozzle adapter bracket screws (see Figure 17).
4. Place hex-shaped aluminum nozzle adapter into vise (do not overtighten).

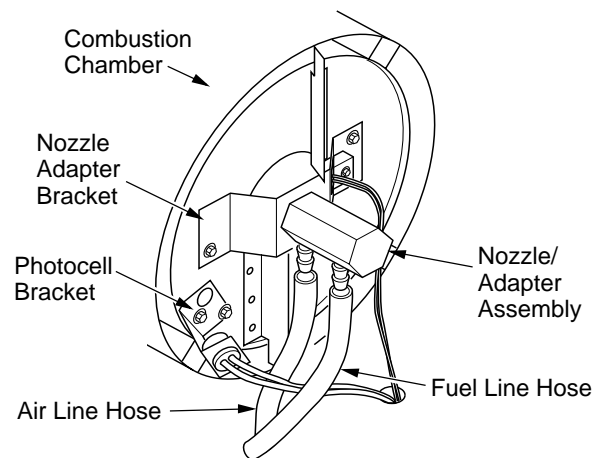

**Figure 17 - Removing Air and Fuel Line Hoses (200T Model Only)**

## SERVICE PROCEDURES

### Continued

- Carefully remove nozzle from nozzle adapter using 5/8" socket wrench (see Figure 18).
- Blow compressed air through face of nozzle. This will remove any debris in nozzle.
- Inspect nozzle seal for damage.
- Replace nozzle into nozzle adapter until nozzle seats. Tighten 80-110 inch-pounds.
- Attach nozzle adapter bracket to combustion chamber with two screws removed in step 3, page 11.
- Repeat steps 9 through 16 under *Ignitor*, page 10.

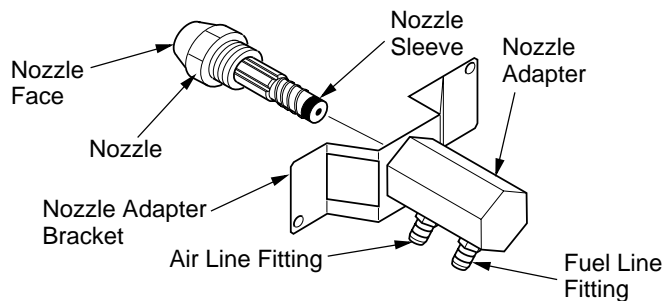

Figure 18 - Nozzle and Nozzle Adapter

### FUEL AND AIR LINE REPLACEMENT AND PROPER ROUTING

- Remove upper shell (see *Upper Shell Removal*, page 8).
- Remove control cover screws using phillips screwdriver (see Figure 11, page 9).
- Remove control cover.
- Inspect fuel and air line hoses for cracks and/or holes. If fuel line hose is damaged, disconnect from nozzle adapter (see Figure 14 or Figure 17 according to model, page 11) and from fuel filter (see *Fuel Filter*, page 9). If air line hose is damaged, disconnect from nozzle adapter (see Figure 14 or Figure 17 according to model, page 11) and from barb fitting on pump end cover (see Figure 19).
- Install new air and/or fuel line. Attach one end of air line hose to barb fitting on pump end cover (see Figure 19) and the other end to nozzle adapter (see Figure 14 or Figure 17 according to model, page 11). Attach one end of fuel line hose to fuel filter (see *Fuel Filter*, page 9) and the other end to nozzle adapter (see Figure 14 or Figure 17 according to model, page 11).

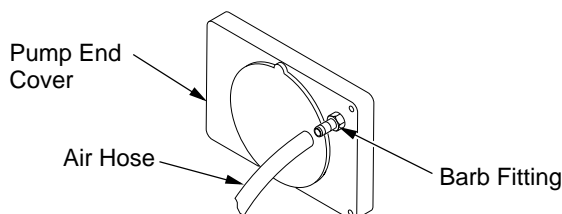

Figure 19 - Air Hose to Barb Fitting

*Note:* Route hoses as shown in Figure 14 or Figure 17 according to model, page 11. Hoses are not to touch photocell bracket.

- Replace control cover.
- Replace upper shell (see *Upper Shell Removal*, page 8).

### PUMP ROTOR (Procedure if Rotor is Binding)

- Remove upper shell (see *Upper Shell Removal*, page 8).
- Remove fan guard.
- Remove filter end cover screws using 5/16" nut driver (see Figure 20).
- Remove filter end cover and air filters.
- Remove pump plate screws using 5/16" nut-driver.
- Remove pump plate.
- Remove rotor, insert, and blades (see Figure 20).
- Check for debris in pump. If debris is found, blow out with compressed air.
- Install insert and rotor.
- Check gap on rotor. Adjust to .076/.101 mm (.003"/.004") if needed (see Figure 21).

*Note:* Rotate rotor one full turn to ensure the gap is .076/.101 mm (.003"/.004") at tightest position. Adjust if needed.

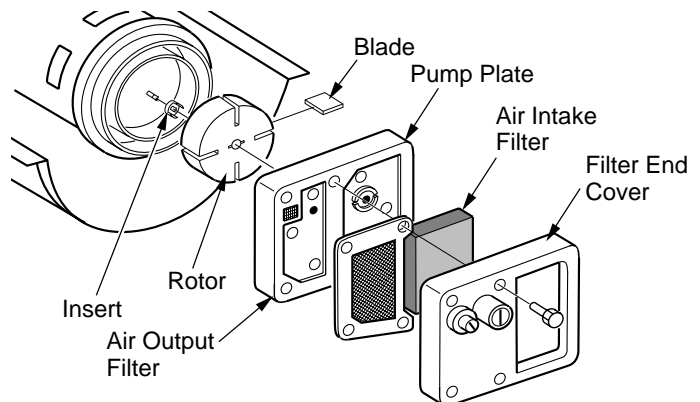

Figure 20 - Rotor Location

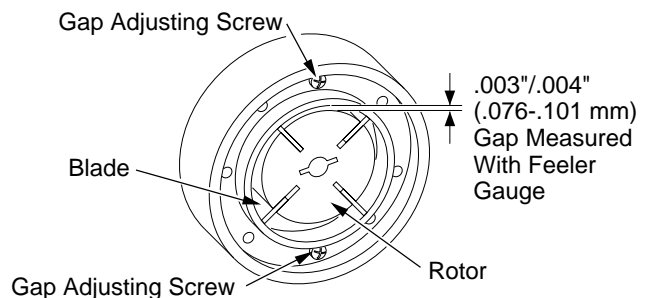
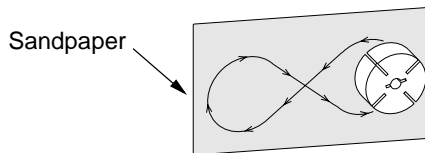

Figure 21 - Gap Adjusting Screw Locations

## SERVICE PROCEDURES

### Continued

11. Install blades, pump plate, air filters, and filter end cover.
12. Replace fan guard and upper shell (see *Upper Shell Removal*, page 8).
13. Adjust pump pressure (see *Pump Pressure Adjustment*, page 9).  
*Note:* If rotor is still binding, proceed as follows.
14. Perform steps 1 through 6, page 12.
15. Place fine grade sandpaper (600 grit) on flat surface. Sand rotor lightly in “figure 8” motion four times (see Figure 22).
16. Reinstall insert and rotor.
17. Perform steps 10 through 12, page 12.

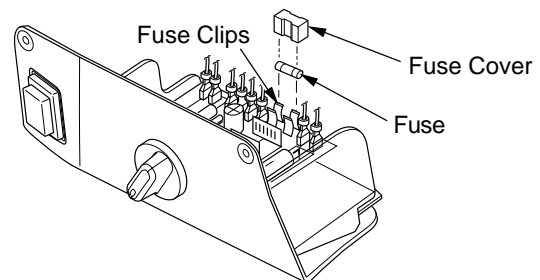

**Figure 22 - Sanding Rotor**

## IGNITION CONTROL ASSEMBLY

**⚠ WARNING: High voltage!**

1. Unplug heater.
2. Remove control cover screws (2) using phillips screwdriver to expose ignition control assembly (see Figure 11, page 9).
3. Remove fuse cover.
4. Remove fuse from fuse clips.
5. Replace with new fuse (DESA part number 105880-02). Do not substitute a fuse with a higher current rating. Use Bussmann GMA-10 or equivalent.
6. Replace fuse cover.
7. Replace control cover (see Figure 11, page 9).



**Figure 23- Replacing Fuse**

## SPECIFICATIONS

Model Size	125T	170T	200T
Output Rating (Btu/Hr)	125,000	170,000	200,000
Fuel	Use only kerosene, #1/#2 diesel/fuel oil, JET A or JP-8 fuels*		
Fuel Tank Capacity (U.S. Gal./Liters)	13.5/51	13.5/51	13.5/51
Fuel Consumption (Gal. Per Hr/Liters Per Hr)	.90/3.41	1.25/4.73	1.4/5.3
Pump Pressure (psi)	6.0	6.0	6.2
Electric Requirements	120 V/60 HZ	120 V/60 HZ	120 V/60 HZ
Amperage (Normal Run)	3.6	3.6	3.6
Maximum Motor Speed (RPM)	3400	3400	3400
Hot Air Output (CFM)	520	580	600
Motor Horsepower	1/5	1/5	1/4
Shipping Weight (Approximate Pounds/Kilograms)	77/34.9	78/35.4	83/37.6
Heater Weight without Fuel (Approximate Pounds/Kilograms)	69/31.3	70/31.8	75/34

\* Use of #2 diesel/fuel oil will result in noticeable odor and could require additional fuel filter maintenance. Use in extreme cold temperatures may require nontoxic anti-icer additives.

# ILLUSTRATED PARTS BREAKDOWN

<u>125T Models</u>	<u>170T Models</u>
RH125T	RH170T
RHD125T	RHD170T
RL125T	RL170T
M125T	M170T

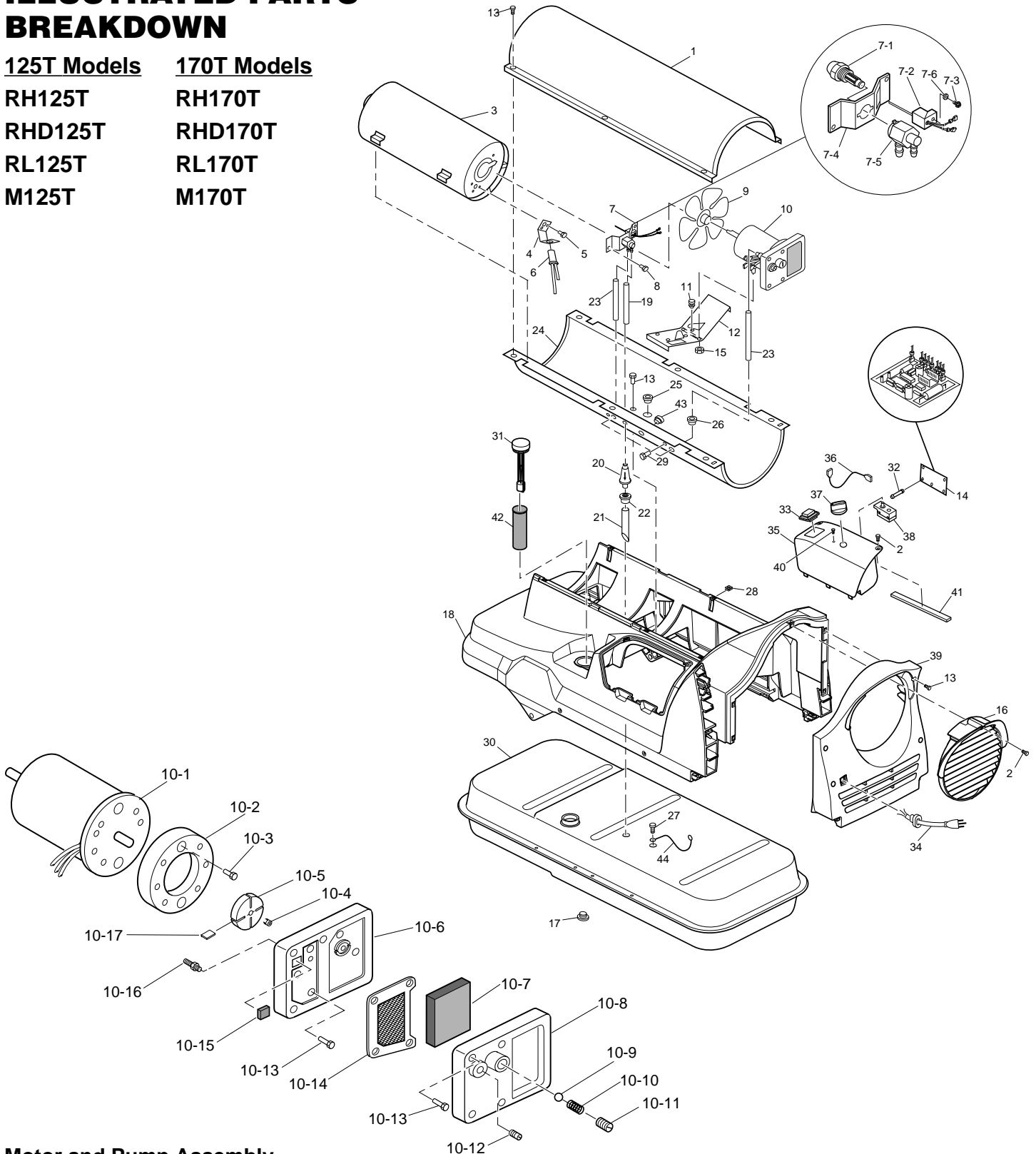

**Motor and Pump Assembly**

For more information, visit [www.desatech.com](http://www.desatech.com)

## PARTS LIST

**125T Models    170T Models**

**RH125T            RH170T**

**RHD125T        RHD170T**

**RL125T          RL170T**

**M125T          M170T**

This list contains replaceable parts used in your heater. When ordering parts, be sure to provide the correct model and serial numbers (from the model plate), then the part number and description of the desired part.

KEY NO.	PART NUMBER	DESCRIPTION	QTY.	KEY NO.	PART NUMBER	DESCRIPTION	QTY.
1	107353-10	Upper Shell (Service Part Will Be Black)	1	12	101206-01	Motor Mounting Bracket	1
2	108631-01	Screw, #10-16 x 1"	3	13	M11084-29	Screw, #10-16 x 3/4"	11
3	098512-71	Combustion Chamber (125T)	1	14	104068-02	Ignition Control Assembly	1
	098512-73	Combustion Chamber (170T)	1	15	NTC-4C	Hex Lock Nut, 1/4-20	2
4	103154-05	Photocell Bracket	1	16	108460-01	Fan Guard	1
5	M10908-2	Screw, #6-32 x 3/8"	2	17	M27417	Drain Plug (Includes "o" Ring)	1
6	M16656-21	Photocell Assembly	1	18	108457-01	Shroud	1
7	Δ	Burner Head Assembly	1	19	M51345-12	Fuel Line (125T)	1
7-1	HA3027	Nozzle Assembly (125T)	1	20	M51345-09	Fuel Line (170T)	1
	HA3029	Nozzle Assembly (170T)	1	21	106896-01***	Fuel Filter	1
7-2	102548-07	Ignitor Kit	1	22	M51151-02	Fuel Line Tube	1
7-3	M10908-75	Screw	1	23	M10990-3	Rubber Bushing	1
7-4	102336-01	Nozzle Adapter Bracket	1	24	M50814-08	Airline (125T)	1
7-5	104054-01	Nozzle Adapter	1		M50814-03	Airline (170T)	1
7-6	103347-01	Washer	1		107353-11	Lower Shell (Service Part Will Be Black)	1
8	M11084-26	Screw, #10-16 x 3/8"	2	25	M50104-06	Bushing	2
9	097293-01	Fan (125T)		26	M50104-01	Bushing	1
	102042-01	Fan (170T)	1	27	M12461-51	Screw, #10-16 x 0.38"	1
10	Δ	Motor and Pump Assembly	1	28	108708-01	Clip Nut	13
10-1	102001-30	Motor	1	29	M10908-14	Screw, #8-32 x 1/4"	1
10-2	079975-02	Pump Body	1	30	108088-12	Fuel Tank	1
10-3	FHPF3-5C	Screw, #10-32 x 5/8"	2	31	097663-03	Fuel Cap/Gauge	1
10-4	M22009**	Rotor Insert	1	32	108668-01	P.C. Board Support	5
10-5	M22456-1**	Pump Rotor	1	33	108394-01	ON/OFF Switch	1
10-6	M50545	Pump End Cover	1	34	107994-01	Power Cord	1
10-7	M12179***	Intake Filter	1	35	108461-01	Control Cover	1
10-8	M16545	Filter End Cover	1	36	M9900-170	Wire Assembly, Black	2
10-9	M8940∞	Steel Ball, 1/4" Diameter	1	37	104460-01	Knob	1
10-10	M10993-1∞	Relief Spring	1	38	104458-01	Thermostat	1
10-11	M27694∞	Adjusting Screw	1	39	108458-01	Rear Panel	1
10-12	M22997∞	Plug	1	40	M12461-18	Screw, #8-32 x 7/8"	1
10-13	M12461-31	Screw, #10-32 x 1"	10	41	097785-08	Foam Gasket	1
10-14	M12244-1***	Output Filter	1	42	108739-01	Filler Neck Screen	1
10-15	M11637***	Lint Filter	1	43	097467-02	Button Plug	1
10-16	104096-01	Fitting, Straight Nylon Barb	1	44	M9900-197	Wire Assembly, Green	1
10-17	M8643**	Blade	4		105880-02	Fuse (Not Shown)	1
11	M50631	Rubber Bumper	2				

Δ Not available as an assembly

\*\* Included in Rotor Kit (Part No. HA3004)

\*\*\* Included in Filter Kit (Part No. HA3017)

∞ Included in Pump Adjustment Kit (Part No. HA3020)





# PARTS LIST

## 200T Models

### M200T

### RHD200T

This list contains replaceable parts used in your heater. When ordering parts, be sure to provide the correct model and serial numbers (from the model plate), then the part number and description of the desired part.

KEY NO.	PART NUMBER	DESCRIPTION	QTY.	KEY NO.	PART NUMBER	DESCRIPTION	QTY.
1	107353-10	Upper Shell (Service Part Will Be Black)	1	10-17	M8643-2**	Blade	4
2	108631-01	Screw, #10-16 x 1"	3	10-18	M12461-32	Screw, #10-32 x 1 1/8"	6
3	098512-69	Combustion Chamber	1	11	M50631	Rubber Bumper	2
4	107791-01	Photocell Bracket	1	12	101206-01	Motor Mounting Bracket	1
5	M10908-2	Screw, #6-32 x 3/8"	2	13	M11084-29	Screw, #10-16 x 3/4"	11
6	M16656-21	Photocell Assembly	1	14	104068-02	Ignition Control Assembly	1
7	Δ	Burner Head Assembly	1	15	NTC-4C	Hex Lock Nut, 1/4-20	2
7-1	100735-13	Nozzle Assembly	1	16	108460-01	Fan Guard	1
7-2	M10659-1	Nozzle Washer	2	17	M27417	Drain Plug (Includes "o" Ring)	1
7-3	M10809-1	Nozzle Spring	1	18	108457-01	Shroud	1
7-4	M8882	Nozzle Sleeve	1	19	M51345-04	Fuel Line	1
7-5	107272-01	Retaining Ring	1	20	106896-01***	Fuel Filter	1
7-6	102336-03	Nozzle Adapter Bracket	1	21	M51151-02	Fuel Line Tube	1
7-7	102548-07	Ignitor Kit	1	22	M10990-3	Rubber Bushing	1
7-8	103347-01	Belleville Washer	1	23	M50814-03	Airline	1
7-9	M10908-75	Screw, #6-32 x .88	1	24	107353-11	Lower Shell (Service Part Will Be Black)	1
7-10	107273-01	Nozzle Adapter	1	25	M50104-06	Bushing	2
7-11	M50820-02	Barb Fitting	1	26	M50104-01	Bushing	1
8	M11084-26	Screw, #10-16 x 3/8"	2	27	M12461-51	Screw, #10-16 x 1/2"	1
9	102042-01	Fan	1	28	108708-01	Clip Nut	13
10	Δ	Motor and Pump Assembly	1	29	M10908-14	Screw, #8-32 x 1/4"	1
10-1	102001-27	Motor	1	30	108088-12	Fuel Tank	1
10-2	079975-03	Pump Body	1	31	097663-03	Fuel Cap/Gauge	1
10-3	FHPF3-6C	Screw, #10-32 x 3/4"	2	32	108668-01	P.C. Board Support	5
10-4	M22009**	Rotor Insert	1	33	108394-01	ON/OFF Switch	1
10-5	M22456-2**	Pump Rotor	1	34	107994-01	Power Cord	1
10-6	M50545	Pump End Cover	1	35	108461-01	Control Cover	1
10-7	M12179***	Intake Filter	1	36	M9900-170	Wire Assembly, Black	2
10-8	M16545	Filter End Cover	1	37	104460-01	Knob	1
10-9	M8940∞	Steel Ball, 1/4" Diameter	1	38	104458-01	Thermostat	1
10-10	M10993-1∞	Relief Spring	1	39	108458-01	Rear Panel	1
10-11	M27694∞	Adjusting Screw	1	40	M12461-18	Screw, #8-32 x 7/8"	1
10-12	M22997∞	Plug	1	41	097785-08	Foam Gasket	1
10-13	M12461-31	Screw, #10-32 x 1"	4	42	108739-01	Filler Neck Screen	1
10-14	M12244-1***	Output Filter	1	43	097467-02	Button Plug	1
10-15	M11637***	Lint Filter	1	44	M9900-197	Wire Assembly, Green	1
10-16	M50820-02	Barb Fitting	1		105880-02	Fuse (Not Shown)	1

Δ Not available as an assembly

\*\* Included in Rotor Kit (Part No. HA3005)

\*\*\* Included in Filter Kit (Part No. HA3017)

∞ Included in Pump Adjustment Kit (Part No. HA3020)

## WHEELS AND HANDLE

### WHEELS AND HANDLE PARTS LIST

KEY NO.	PART NUMBER	PART DESCRIPTION	QTY.
1	108459-01	Handle/Support	1
2	WP 4C	Washer	6
3	108630-01	Screw	6
4	108463-01	Extension Cord Wrap	2
5	M16801-5	Axle	1
6	108468-01	Washer	2
7	107426-01	Wheel Kit (Contains: 2 Wheels and Cap Nuts)	2
8	M28526	Cap Nut	2

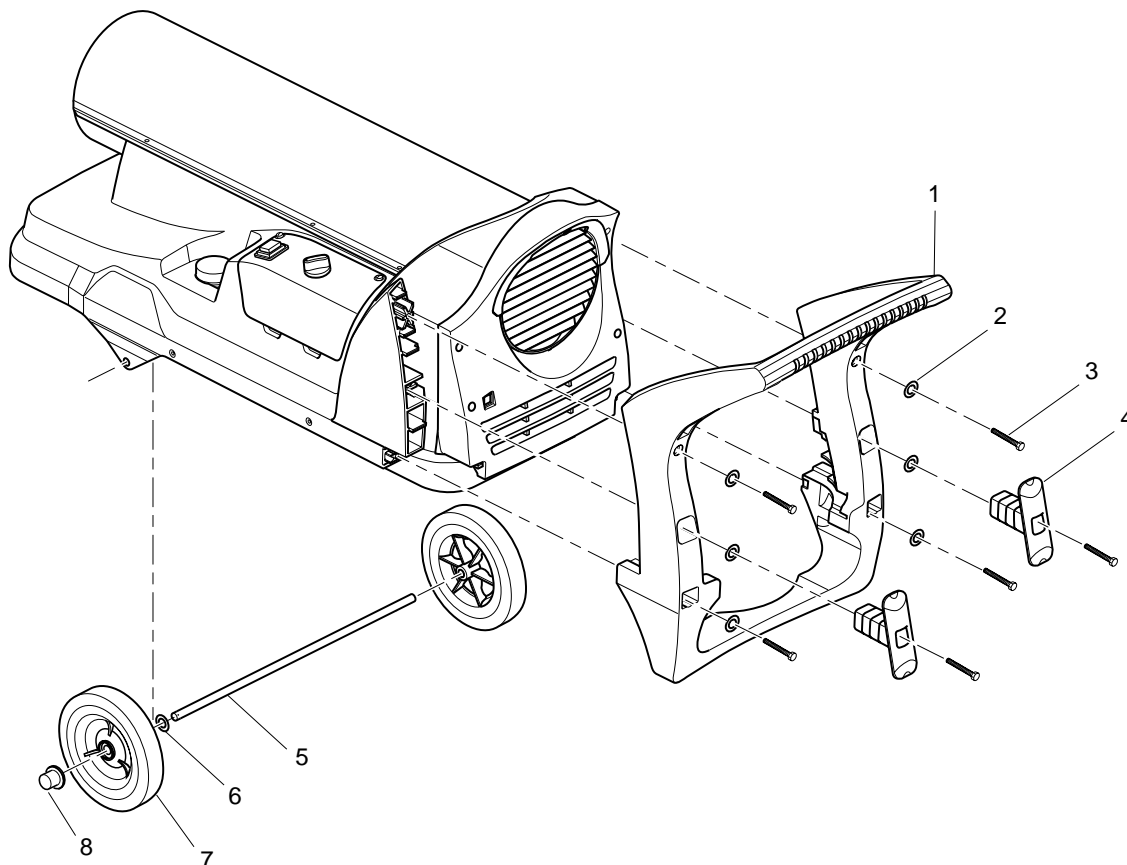

## WIRING DIAGRAM

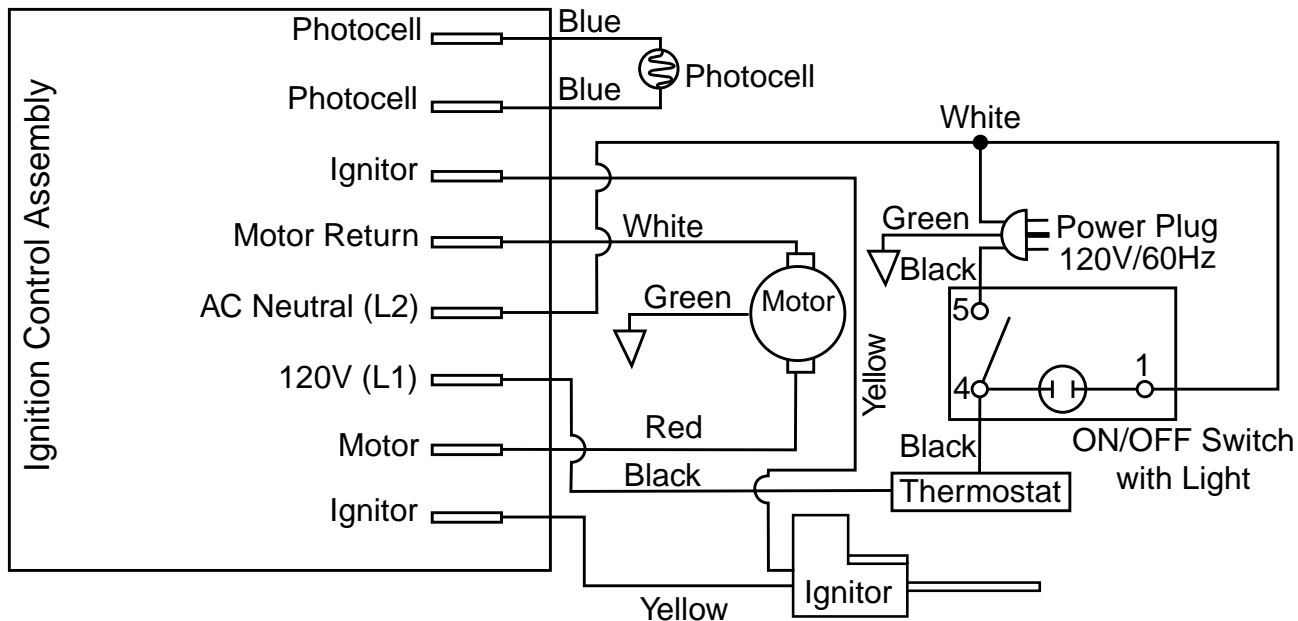

## TECHNICAL SERVICE

You may have further questions about installation, operation, or troubleshooting. If so, contact DESA International's Technical Service Department at 1-866-672-6040.

You can also visit DESA International's technical services web site at [www.desatech.com](http://www.desatech.com).

## REPLACEMENT PARTS

*Note:* Use only original replacement parts. This will protect your warranty coverage for parts replaced under warranty.

### PARTS UNDER WARRANTY

Contact authorized dealers of this product. If they can't supply original replacement part(s), call DESA International's Technical Service Dept. at 1-866-672-6040.

When calling DESA International, have ready:

- your name
- your address
- model and serial numbers of your heater
- how heater was malfunctioning
- purchase date

Usually, we will ask you to return the part to the factory.

### PARTS NOT UNDER WARRANTY

Contact authorized dealers of this product. If they can't supply original replacement part(s), call DESA International at 1-866-672-6040 for referral information. Parts dealers are listed in the Authorized Service Center booklet supplied with heater.

When calling DESA International, have ready:

- model and serial numbers of your heater
- the replacement part number

## ACCESSORIES

Purchase accessories and parts from your nearest dealer or service center. If they can not supply these accessories or parts, either contact your nearest parts dealer or DESA International at 1-866-672-6040 for referral information. Parts Centrals are listed in the Authorized Service Center booklet supplied with heater.

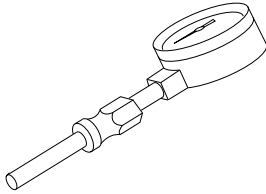

### AIR GAUGE KIT - HA1180

For all models. Special tool to check pump pressure.

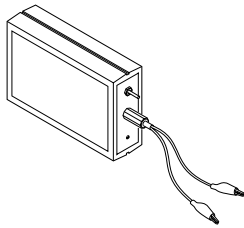

### IGNITION CONTROL ASSEMBLY/PHOTOCELL TESTER - HA1170

Special tool used to test the ignition control assembly and photocell.

# OWNER'S REGISTRATION FORM

Complete registration form and mail or complete on-line registration at [www.desatech.com](http://www.desatech.com) within 30 days after purchase.

Brand: \_\_\_\_\_ (Reddy Heater, Master, Remington, etc.)  
 Model: \_\_\_\_\_ (R60, HD15, etc.)  
 Date Purchased: \_\_\_\_\_ Note: Keep receipt for warranty verification.  
 Serial Number: \_\_\_\_\_ 7 or 9 digit number located on product or identification tag.  
 First Name: \_\_\_\_\_ Last Name: \_\_\_\_\_  
 Address: \_\_\_\_\_  
 City: \_\_\_\_\_ State: \_\_\_\_\_ Zip: \_\_\_\_\_ Country: \_\_\_\_\_  
 Phone: (\_\_\_\_) \_\_\_\_\_ - \_\_\_\_\_ E-Mail: \_\_\_\_\_

Please answer the following questions to register your product with DESA International:

1. Who will heater be used by?  Individual  Business
2. Will you use your heater in more than one location?  Yes  No
3. Where will the product be used? (You may select more than one.)  Workshop  Workshop  Barn  Residential Construction  
 Commercial Construction  Garage  Factory  Recreation  Warehouse  Utility Shed/Outbuilding  
 Other \_\_\_\_\_ (Specify)
4. Cost of product (excluding sales tax)? \$ \_\_\_\_\_
5. Maintenance/service work will be performed by:  Self  Service Center  Other \_\_\_\_\_
6. If you bought this product yourself, did you plan to purchase this type of product before going into the store?  Yes  No
7. Type of store where product was purchased?  Hardware  Propane Dealer  Natural Gas/Utility Co.  Home Center or Builder's Supply  
 Farm/Ag. Supply  Auto Parts  Warehouse Club  Industrial/Contractor Supply  Rental Store  
 Discount Store  HVAC Dealer  Other \_\_\_\_\_
8. What is your primary source of heat?  Propane (LP Gas)  Natural Gas  Kerosene  Diesel  Electric  Other \_\_\_\_\_
9. What motivated you to buy this product?  Sudden Cold Weather  Replace Older Model  D.I.Y. Home Project  Emergency Back-Up Heat  
 Heater on Sale  Construction Project  Hard to Heat Location  Other \_\_\_\_\_
10. How did you learn about this product brand?  Advertisement  Relative or Friend  Co-Worker  Store Representative  
 Store Display  Previously Owned a Heater  Other \_\_\_\_\_ (Specify)
11. What other brands did you consider?  None  Master  Remington  All-Pro  Dayton  Universal  Mr. Heater  L.B. White Tradesman  
 John Deere  Dyna-Glo  Dura-Heat  Paulin  Coleman  Vogelzang American  Other \_\_\_\_\_
12. Who selected the product?  Male  Female  Both
13. Level of Education of Purchaser:  High School  Vocation/Technical School  Some College  Completed College  Graduate School
14. Age of Purchaser:  Under 20  20 - 29  30 - 39  40 - 49  50 - 59  60 or Over
15. Buyer's total annual household income:  Under \$19,999  \$20,000 to \$34,999  \$35,000 to \$49,999  
 \$50,000 to \$74,999  \$75,000 to \$99,999  \$100,000 and Over
16. What is the population of your area?  Under 10,000  10,000 to 25,000  25,000 to 50,000  50,000 to 100,000  
 100,000 to 250,000  Over 250,000
17. Store where product was purchased:  
 Name: \_\_\_\_\_ City: \_\_\_\_\_ State: \_\_\_\_\_
18. In choosing this product, how important were the following:
 

	Not	Somewhat	Very		Not	Somewhat	Very
Availability	<input type="radio"/>	<input type="radio"/>	<input type="radio"/>	Size	<input type="radio"/>	<input type="radio"/>	<input type="radio"/>
Price	<input type="radio"/>	<input type="radio"/>	<input type="radio"/>	Prior Brand Experience	<input type="radio"/>	<input type="radio"/>	<input type="radio"/>
Brand Name	<input type="radio"/>	<input type="radio"/>	<input type="radio"/>	Built-In Thermostat	<input type="radio"/>	<input type="radio"/>	<input type="radio"/>
Overall Quality	<input type="radio"/>	<input type="radio"/>	<input type="radio"/>	Ease of Operation	<input type="radio"/>	<input type="radio"/>	<input type="radio"/>
Heat Output (Btu/Hr Rating)	<input type="radio"/>	<input type="radio"/>	<input type="radio"/>	Special Features	<input type="radio"/>	<input type="radio"/>	<input type="radio"/>
Variable Heat Output (Btu/Hr)	<input type="radio"/>	<input type="radio"/>	<input type="radio"/>	Salesperson's Recommendation	<input type="radio"/>	<input type="radio"/>	<input type="radio"/>
Made in USA	<input type="radio"/>	<input type="radio"/>	<input type="radio"/>	Friend/Relative's Recommendation	<input type="radio"/>	<input type="radio"/>	<input type="radio"/>
Warranty	<input type="radio"/>	<input type="radio"/>	<input type="radio"/>	Portability	<input type="radio"/>	<input type="radio"/>	<input type="radio"/>
Local Service	<input type="radio"/>	<input type="radio"/>	<input type="radio"/>	Quiet Operation	<input type="radio"/>	<input type="radio"/>	<input type="radio"/>
Value for Price	<input type="radio"/>	<input type="radio"/>	<input type="radio"/>				
19. This question will allow us to better understand the demographic profile of our customers. Which of the following best describes you? (not required)  
 African American  Asian American  Mexican  Puerto Rican  Cuban  Other Hispanic  White  Other \_\_\_\_\_

TAPE

---

---

---

---

Postage  
Required

**DESA**<sup>TM</sup>  
INTERNATIONAL  
2701 Industrial Drive  
P.O. Box 90004  
Bowling Green, KY 42102-9004

TAPE

# OTHER OUTDOOR HEATING PRODUCTS

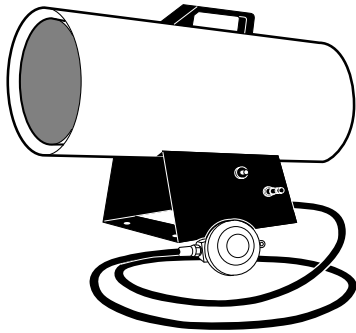

**PROPANE/LP FORCED AIR HEATERS**

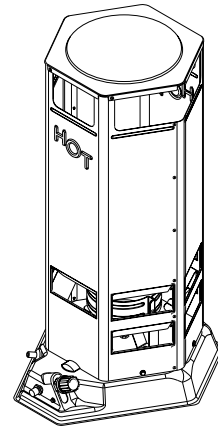

**PROPANE/LP CONVECTION HEATERS**

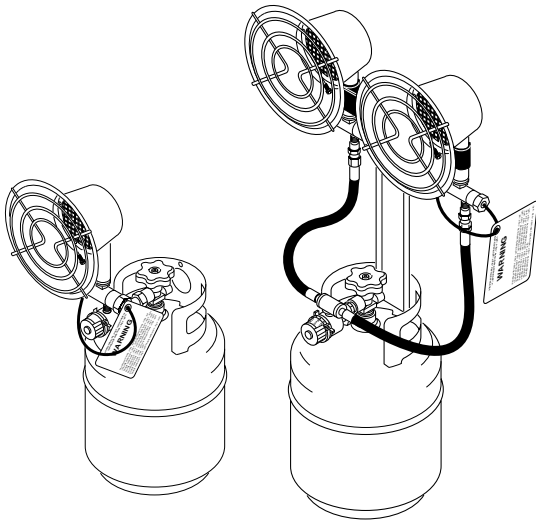

**PROPANE/LP TANK TOP HEATERS**

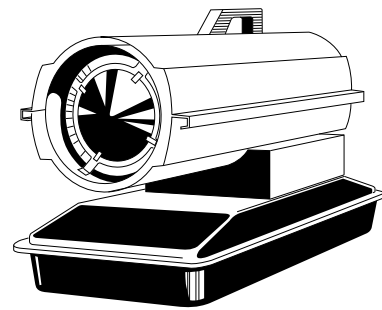

**PORTABLE KEROSENE/DIESEL FORCED AIR HEATERS**

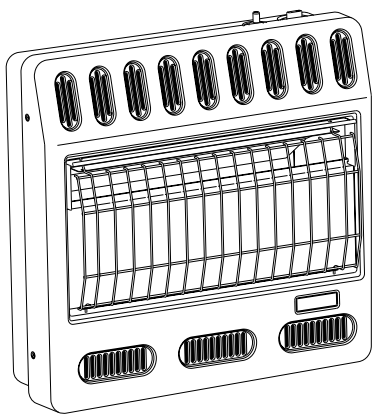

**PROPANE/LP AND NATURAL GAS GARAGE HEATERS**

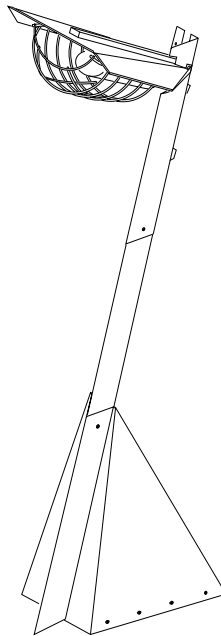

**PROPANE/LP PATIO HEATERS**



**PROPANE/LP AND NATURAL GAS CHIMENEAS**

# WARRANTY AND REPAIR SERVICE

## LIMITED LIFETIME WARRANTY

DESA International warrants the following parts only (no labor) thereof, to be free of defects in materials and workmanship for lifetime from the date of first purchase when operated and maintained in accordance with instructions. This warranty is extended only to the original retail purchaser, when proof of purchase is provided. **(Excludes Rental Use Applications)**

Warranty Covers: Wheels  
Fuel Tank  
Exterior Plastic Housing Parts:  
(Shroud, Rear Panel, Fan Guard, Handle/Support, Extension Cord Wrap Cleats and Control Cover)

This warranty covers only the cost of parts (no labor) required to restore the product to proper operating condition. Transportation and incidental costs associated with warranty repairs are not reimbursable under this warranty.

## LIMITED 2-YEAR WARRANTY

DESA International warrants this product and any parts thereof, to be free of defects in materials and workmanship for two (2) years from the date of first purchase when operated and maintained in accordance with instructions. This warranty is extended only to the original retail purchaser, when proof of purchase is provided.

This warranty covers only the cost of parts and labor required to restore the product to proper operating condition. Transportation and incidental costs associated with warranty repairs are not reimbursable under this warranty.

## WARRANTY INFORMATION

This warranty does not cover damage resulting from misuse, abuse, negligence, accidents, lack of proper maintenance, normal wear, alteration, modification, tampering, contaminated fuels, repair using improper parts, or repair by anyone other than an authorized dealer or service center.

Routine maintenance is the responsibility of the owner.

THIS EXPRESS WARRANTY IS GIVEN IN LIEU OF ANY OTHER WARRANTY EITHER EXPRESSED OR IMPLIED, INCLUDING WARRANTIES OF MERCHANTABILITY AND FITNESS FOR A PARTICULAR PURPOSE.

DESA International assumes no responsibility for indirect, incidental or consequential damages. Some states do not allow the exclusion or limitation of incidental or consequential damages or limitations or exclusions may not apply to you. This limited warranty gives you specific legal rights, which vary from state to state.

## WARRANTY SERVICE

Warranty service is available only through authorized dealers and service centers.

Should your heater require service, return it to your nearest authorized service center. Proof of purchase must be presented with the heater. The heater will be inspected. Faulty materials or workmanship may cause a defect. If so, DESA International will repair or replace the heater without charge.

## REPAIR SERVICE

Return the heater to your nearest authorized service center. Each service center is independently owned and operated. Repairs not covered by the warranty will be billed at standard prices. We reserve the right to amend these specifications at any time without notice.

Illustrated parts lists can be obtained free of charge. Send a self addressed stamped envelope to the address listed below. List the heater model number and the date located in the lower right corner of this page. A service manual can be purchased from the address listed below. Send a check for \$5.00 payable to DESA International.

When writing for information regarding your heater, be sure to include the model number and serial number as shown on the model plate.

For more information about this warranty, write:

**DESA**<sup>TM</sup>  
**INTERNATIONAL**  
2701 Industrial Drive  
P.O. Box 90004  
Bowling Green, KY 42102-9004  
www.desatech.com



NOT A UPC

109891-01  
Rev. A  
03/02

Printed in U.S.A.

For more information, visit [www.desatech.com](http://www.desatech.com)