

MK-VTS/50 OWNER'S MANUAL & OPERATING INSTRUCTIONS



Revision 105	11.2012
Manual Part No. 167790	

Caution: Read all safety and operating instructions before using this equipment. This owners manual **MUST** accompany the equipment at all times.

We at MK Diamond want to congratulate you on selecting the MK-VTS/50 Floor Scraper. We are certain that you will be pleased with your purchase. MK Diamond takes pride in producing the finest products in the industry.

Operated correctly, your MK-VTS/50 Floor Scraper should provide you with years of quality service. In order to help you, we have included this manual. This owners manual contains information necessary to operate and maintain your MK-VTS/50 Floor Scraper safely and correctly. Please take a few minutes to familiarize yourself with the MK-VTS/50 Floor Scraper by reading and reviewing this manual.

If you should have questions concerning your MK-VTS/50 Floor Scraper, please feel free to call our friendly customer service department at: 800 421-5830

Regards,

MK Diamond

NOTE THIS INFORMATION FOR FUTURE USE:

MODEL NUMBER:	
SERIAL NUMBER:	
PURCHASE PLACE:	
PURCHASE DATE:	

NOTE: For your (1) one year warranty to be effective, complete the warranty card (including the Serial Number) and mail it in as soon as possible.

	Page
SAFETY	
Safety Message/Alert Symbols, Warnings	4
Hazard Symbols	5
General, Maintenance, Saw Safety	6-7
California proposition 65 Message	8
Electrical Requirements and Grounding Instructions	9
Safety Label Locations	10
Transportation	12
OPERATION	
Wheel and Handle Adjustment	11-12
Blade Changing / Installation	13
Blade Usage	14
TYPE OF TEAROUTS	
Removal Materials	15
Subfloor Surfaces	16
MAINTENANCE	
Cleaning	17
Repairs	17
Troubleshooting	17
GENERAL PRODUCT INFORMATION	
Part List	18-20
ORDERING AND RETURNING INSTRUCTIONS	
Ordering Information	21
Return Material Policy	21
Packaging Instructions	21
Authorized Service Centers	21

Safety precautions should be followed at all times when operating this equipment. Failure to read and understand the Safety Precaution and Operating Instructions could result in injury to yourself and others.

Before using this machine, ensure that the person operating the machine has read and understands all instructions in this manual.

SAFETY MESSAGE / ALERT SYMBOLS

A safety message alerts you to potential hazards that could hurt you or others. Each safety message is preceded by a safety alert symbol () and one of three words: **DANGER**, **WARNING**, or **CAUTION**.

DANGER

You **WILL** be **KILLED** or **SERIOUSLY INJURED** if you do not follow directions.

WARNING

You **CAN** be **KILLED** or **SERIOUSLY INJURED** if you do not follow directions.

CAUTION

You **CAN** be **INJURED** if you do not follow directions. It may also be used to alert against unsafe practices.

Each message tells you what the hazard is, what can happen, and what you can do to avoid or reduce injury. Other important messages are preceded by the word **NOTICE**.

NOTICE

You can cause **PROPERTY DAMAGE** to your machine if you don't follow directions.

The safety labels should be periodically inspected and cleaned by the user to maintain good legibility at a safe viewing distance. If the label is worn, damaged or illegible, it should be replaced.

SAFETY PRECAUTIONS



ALWAYS read this Owner's Manual before operating the machine.



ALWAYS avoid inhalation of and skin contact with silica dust and/or mist.



ALWAYS place the power ON/OFF switch in the **OFF** position when the machine is not in use.



ALWAYS wear approved eye protection.



ALWAYS wear approved respiratory protection.



NEVER operate equipment with covers, or guards removed. Keep fingers, hands, hair and clothing away from all moving parts to prevent injury.



ALWAYS use caution around gears. Keep fingers, hands, hair and clothing away from all moving parts to prevent injury.



NEVER touch the power cord with wet hands or while standing in water when it is connected to a power source.



NEVER operate the machine in an explosive atmosphere or near combustible materials.

RULES FOR SAFE OPERATION



DANGER

Failure to follow instructions in this manual may lead to serious injury or even death! This equipment is to be operated by trained and qualified personnel only! This equipment is for industrial use only.

The following safety guidelines should always be used.

GENERAL SAFETY



- **DO NOT** operate or service this equipment before reading this entire manual.

- This equipment should not be operated by persons under 18 years of age.
- **NEVER** operate this equipment without proper protective clothing, shatterproof glasses, steeltoed boots and other protective devices required by the job.
- **NEVER** operate this equipment when not feeling well due to fatigue, illness or taking medicine.
- **NEVER** operate this equipment under the influence of drugs or alcohol.
- Whenever necessary, replace nameplate, operation and safety decals when they become difficult to read.
- **ALWAYS** check the machine for loose bolts before starting.



- **ALWAYS** wear proper respiratory (mask) hearing and eye protection equipment when operating this machine.

- **ALWAYS** store equipment properly when it is not being used. Equipment should be stored in a clean, dry location out of the reach of children.



- **NEVER** leave the machine unattended. Turn off electric motor when unattended.

- **CAUTION** must be observed while servicing the machine. Rotating parts can cause injury if contacted.
- Ensure that any electrical extension cord is protected against damage. Always ensure that the electrical extension cord is not trapped underneath the machine. When using an extension cord, be sure to use one heavy enough to carry the current your product will draw. An undersized cord will cause a drop in line voltage that will result in a loss of power and overheating. The Table shown on page 11 shows the correct AWG size to use depending on cord length and nameplate ampere rating. If in doubt, use the next heaviest gage. The smaller the gage number, the heavier the cord.



- **DO NOT** allow extension cord to come into contact with water or fluids.
- **DO NOT** spray water onto electric motor.
- **NEVER** operate the machine in an explosive atmosphere.

- Before starting the machine, check that all guards are in position and correctly fitted.
- Keep area around the machine clear of obstructions which could cause persons to fall onto moving parts.
- **ALWAYS** ensure that the machine is on level ground before using.
- **DO NOT** overreach. Keep proper footing and balance at all times.

- **NEVER** stand on the tool. Serious injury could occur if a power tool is tipped, or if a cutting tool is unintentionally contacted.
- Become familiar with the controls of the machine before operating. Know how to stop the machine quickly in case of emergency.
- **ALWAYS** secure work. Clamps or a vise should be used to hold work whenever practical. Keeping your hands free to operate a power tool is safer.
- **ALWAYS** disconnect AC power plug from power source before moving, cleaning or servicing the machine.
- **NEVER** leave a tool running unattended. Do not leave a tool until it comes to a complete stop. **ALWAYS** turn a power tool **OFF** when leaving the work area, or when a cut is finished.
- Make sure the OFF/ON power switch on the electric motor is always in the **OFF** position before inserting the machine's power plug into an AC receptacle.
- Operate electric motor only at the specified voltage indicated on the nameplate.
- **NEVER** disconnect any "emergency or safety devices". These devices are intended for operator safety. Disconnection of these devices can cause severe injury, bodily harm or even death! Disconnection of any of these devices will void all warranties.
- Unauthorized equipment modifications will void all warranties. Manufacturer does not assume responsibility for any accident due to equipment modifications.
- **NEVER** use accessories or attachments, which are not recommended by MK Diamond for this equipment. Damage to the equipment and/or injury to user may result.
- Replace damaged cutting blade before operating.
- **NEVER** try to stop a moving blade with your hand.

**WARNING**

NEVER use this machine with any cutter designed for wood working.

MAINTENANCE SAFETY

- **NEVER** lubricate components or attempt service on a running machine.
- Keep the machinery in proper running condition.
- Before using a power tool, check for damaged parts. A guard or any other part that is damaged should be carefully checked to determine if it would operate properly and perform its intended function. Always check moving parts for proper alignment or binding. Check for broken parts and mountings and all other conditions that may affect the operation of the power tool. A guard, or any damaged part, should be properly repaired or replaced.

SAFETY WARNINGS

SILICA DUST WARNING

Grinding/cutting/drilling of masonry, concrete, metal and other materials with silica in their composition may give off dust or mists containing crystalline silica. Silica is a basic component of sand, quartz, brick clay, granite and numerous other minerals and rocks. Repeated and/or substantial inhalation of airborne crystalline silica can cause serious or fatal respiratory diseases, including silicosis. In addition, California and some other authorities have listed respirable crystalline silica as a substance known to cause cancer. When cutting such materials, always follow respiratory precautions.

CALIFORNIA PROPOSITION 65 MESSAGE

Some dust created by power sanding, sawing, grinding, drilling, and other construction activities contain chemicals known (to the State of California) to cause cancer, birth defects or other reproductive harm. Some examples of these chemicals are:

- Lead, from lead-based paints
- Crystalline silica, from bricks and cement and other masonry products
- Arsenic and chromium, from chemically treated lumber

For further information, consult the following sources:

<http://www.osha.gov/dsg/topics/silicacrystalline/index.html>

<http://www.cdc.gov/niosh/consilic.html>

<http://oehha.ca.gov/prop65/law/P65law72003.html>

<http://www.dir.ca.gov/Title8/sub4.html>

Your risk from these exposures varies depending on how often you do this type of work. To reduce your exposure to these chemicals, work in a well-ventilated area, and work with approved safety equipment, such as those dust masks that are specially designed to filter out microscopic particles.

Asbestos Warning

Some floor coverings contain asbestos. Removing, cutting, grinding or otherwise disturbing these coverings can cause asbestos dust to become airborne. Never remove flooring containing asbestos without fully understanding proper state and federal procedures and guidelines for removal of these products. Laws are different from state to state.



WARNING

To reduce the risk of electrocution, keep all connections dry and off the ground.

A Ground Fault Circuit Interrupter (GFCI) should be provided on the circuit(s) or outlet(s) to be used for this machine. Receptacles are available having built-in GFCI protections and may be used for this measure of safety. When using an extension cord, the GFCI should be installed closest to the power source, followed by the extension cord and lastly, the machine.



WARNING

To reduce the risk of injury, electric shock and damage to the tool, never immerse your tool in liquid or allow a liquid to flow inside the tool.

ELECTRICAL REQUIREMENTS AND GROUNDING INSTRUCTIONS

In order to prevent potential electrical shock and injury, the following electrical safety precautions and symbols should be followed at all times!

WARNING

In case of a malfunction or breakdown, grounding provides a path of least resistance for electric current to reduce the risk of electric shock. This tool is equipped with an electric cord having an equipment-grounding conductor and a grounding plug. The plug must be plugged into a matching outlet that is properly installed and grounded in accordance with all local codes and ordinances.

- Do not modify the plug provided – if it will not fit the outlet; have the proper outlet installed by a qualified electrician
- Improper connections of the equipment-grounding conductor can result in a risk of electric shock. The equipment-grounding conductor is the insulated conductor that has an outer surface that is green, with or without yellow stripes. If repair or replacement of the electric cord or plug is necessary, do not connect the equipment-grounding conductor to a live terminal
- Check with a qualified electrician or service personnel if the grounding instructions are not completely understood, or if in doubt as to whether the tool is properly grounded
- Use only 3-wire extension cords that have 3-prong grounding plugs and 3-pole receptacles that accept the tool's plug
- Repair or replace a damaged or worn cord immediately

WARNING

This tool is intended for use on a circuit that has an outlet that looks like the one shown in Sketch A of Figure 1. The tool has a grounding plug that looks like the plug illustrated in Sketch A of Figure 1. A temporary adapter, which looks like the adapter illustrated in sketches B and C, may be used to connect this plug to a 2-pole receptacle as shown in Sketch B, if a properly grounded outlet is not available. The temporary adapter should be used only until a properly grounded outlet can be installed by a qualified electrician. The green-colored rigid ear, lug, and the like, extending from the adapter, must be connected to a permanent ground such as a properly grounded outlet box.

NOTE: Use of a temporary adapter is not permitted in Canada.

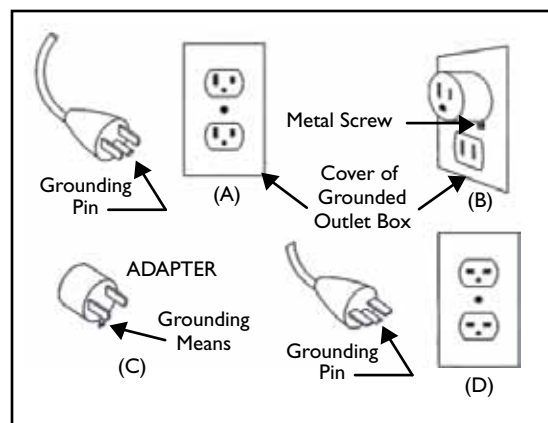
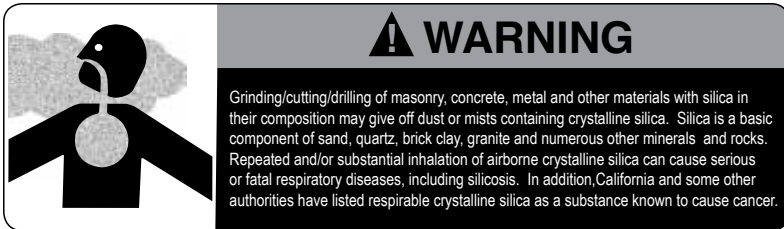

Fig. 1 Circuit and Adapter Information

SAFETY LABEL LOCATIONS

Safety labels contain important safety information. Please read the information contained on each safety label. These labels are considered a permanent part of your saw. If a label comes off or becomes hard to read, contact MK Diamond or your dealer for a replacement.



Label A



Label B

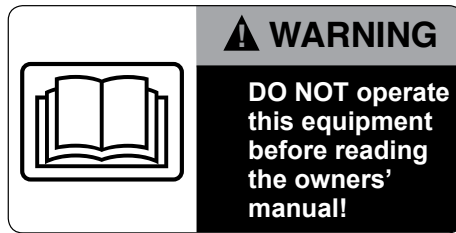

Label C

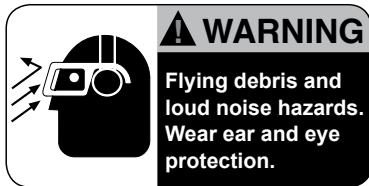

Label D

Warning Sheet Part# 167847

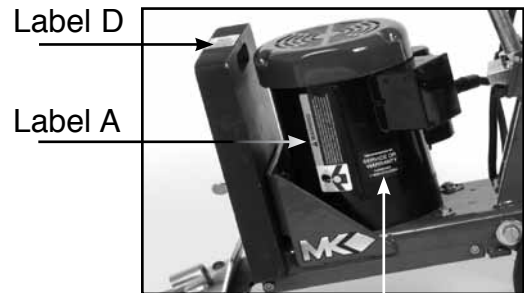
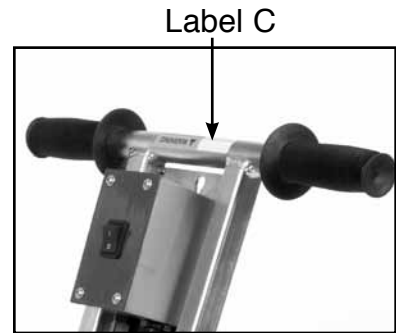

Decal/Label	Location	Description
A	Motor - Side	Warning - Silica Warning
B	Motor - Side	Service/ Warranty
C	Handle	Read Manual
D	Nose Weight-Top	Wear Protection Equipment

! **WARNING**

Do not operate machine around excessive moisture areas, such as abatement work and flooded pool areas without GFCI wall plug. Failure to do so could cause damage in machine or injury to operator.

WHEEL ADJUSTMENT

Adjusting the wheel angle will change the blade angle to the floor. Adjustments may be required for your particular application. Experiment with the angle to see what works the best.

NOTE: Adjustment by trial at the beginning of a job will allow optimum performance. See Blade Setting page 14.



(A)

A steep wheel angle is recommended on hard removals such as vinyl, VCT and carpet over concrete or wood



(B)

A low wheel angle is recommended for ceramic tile and hardwood removal over all floors

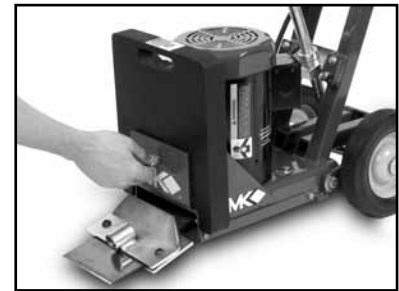

(C)

Turn bolt and remove nose weight



(D)

Lay Floor Scraper back on handles



(E)

Rotate the angle adjustment wheel to the desired blade angle

HANDLE ADJUSTMENT**AFTER THE PROPER WHEEL ADJUSTMENT IS ACHIEVED, ADJUST THE HANDLE LENGTH**

Simply loosen the thumbscrews located on the frame and the handle will slide up and down. Locate the most comfortable height and tighten the thumbscrews to lock the handle in place.



(A)

The handle should be adjusted to the "belt-line" of the operator or to an otherwise comfortable position

TRANSPORTATION

Always remove the counterweight and blades before loading or unloading.

Machine breaks down for easy transportation handle and/or wheel angle can be lowered to reduce overall height.

**WARNING**

Keep hands and feet out from underneath the machine.



(A)

Turn bolt and remove nose weight



(B)

Remove switch box from handle bars



(C)

Remove handle

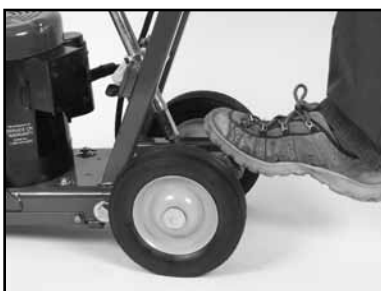

(D)

A kick plate on the back of the chassis provides additional help when moving the machine. Simply step downward on the kick plate to raise the blade and adjust the weight of the head over the wheels.

BLADE CHANGING / INSTALLATION

CAUTION Blades are sharp. Handle with care. Failure to do so could cause bodily injury.

- Dull blades greatly reduce cutting ability. Re-sharpen or replace as needed.
- Proper blade size and placement per job type greatly affects performance.
- Disconnect electrical power first.
- Do not lean machine back onto handle.
- Always wear gloves when changing blades to protect fingers and hands.



(A)

Place a block under the front of the machine, raising the blade holder



(B)

Loosen the two blade cover bolts

1. Place a block under the front of the machine, raising the blade holder as shown in Figure A.
2. Using an allen wrench with an extended socket wrench, with at least a 3" extension to keep hand safely away from the sharp edge of the blade, loosen the two blade cover bolts as shown in Figure B. It is not necessary to remove the bolts.
3. Place the blade into the cutting head, sliding the blade all the way back to the bolts. If the blade is wider than the cutting head, center the blade to the head. If the blade is smaller than the cutting head, for the first pass the blade should be mounted in center of the cutting head. After the first pass is made, blade can be offset in head to allow wheels to keep even contact with the floor and allow easy access to the wall. Blades of longer width can be mounted in either holes or slots or put in front of blade cover bolts.
4. Securely tighten bolts.

BLADE USAGE

1. Start with a narrow blade, then increase blade size to optimize cutting pass. Narrower blades work easier than wider blades and usually clean the floor better. Wider is not always better or faster.
2. Proper blade size and placement, depending on material and sub-floor type, greatly affects performance.
3. Keep in mind, narrow width blades will make a cleaner floor surface.
4. For wood or wood like floors, pound down or remove any nails or metal obstruction to avoid blade damage.
5. When working over plywood sub-floor, try to work in the direction of the wood grain.
6. A new sharp blade being used on wood or alike sub floors may work better when slightly dulled to avoid digging or gouging.
7. When working over concrete, beware of expansion joints and sub-floor mounted receptacles.
8. Keep your work area clean and clear of debris.
9. After you have removed a portion of material, remove it out of the way. This will give the machine maximum performance and help to keep the work area safe.
10. Dull blades greatly reduce cutting ability. Re-sharpen or replace as needed.
11. Use Sawtec® replacement blades.

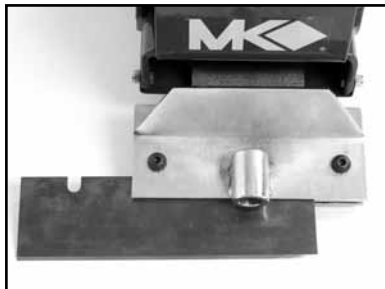

(A)

Blades can be offset in cutting head for easier access to toe kicks or removal along the wall

REMOVAL MATERIALS



WARNING

Never remove flooring containing asbestos without fully understanding proper state and federal procedures and guidelines.

- Sheet vinyl, solid vinyl, rubber tile, urethane or PVC sheet roofing, will need to be scored for best removal results.
- **VCT TILE:** If goods being removed still do not come up clean or machine jumps on top of goods, reduce blade size to a smaller blade until proper blade size is found or use a smaller portion of the blade. Never use a blade wider than the size of the tile being removed.
- **PURE VINYL RUBBER TILE:** Self scoring blades can be used with some materials. A 10" blade is recommended for this product, but determine what size blade works best. Goods will need to be scored down to 10 to 12 inches for proper removal.
- **DIRECT GLUED CARPET:** Pre-scored carpet makes machine easier to control and blades stay sharper longer. Pre-score carpet to blade width prior to stripping. Normally 12" to 14" blades are used on direct glued carpet, secondary backed, unitary, double glued, vinyl foam, urethane foam.
- **CERAMIC:** Ceramic over a wood sub-floor requires a low angle so the blade is flat to the floor. Ceramic over hard sub-floor such as concrete, angle can be increased. Experiment with the angle to see which works the best. Requires a Ceramic Bit.

SUBFLOOR SURFACES

- **WOOD:** When working over plywood sub-flooring, try to run machine in the same direction as the grain in the wood. Blade in most cases should be bevel down. On solid wood floors, like plank, run in the same direction as the plank, not cross grain or cross plank. Removing the front counter weight will help on all soft surfaces.
- **CONCRETE:** When working on a concrete slab, normal blade position is bevel up for best performance, especially when cleaning adhesive. On occasion, bevel down gives better blade life. Test each job for best performance.
- **GIBCRETE AND SOFT POURED FLOORING:** Usually requires blade bevel down to create a better wearing surface, although bevel up may work if front counter weight is removed.



BEVEL DOWN
WOOD FLOORS



BEVEL UP
CONCRETE FLOORS

NOTE: Normally bevel on blade is up for concrete. Bevel down for wood or soft sub-floors.



CAUTION

Beware of expansion joints and floor mounted receptacles or other obstacles in the floor.

- **GLUED HARD WOOD FLOORING:** A 10" blade is recommended for regular adhesive, a 6" - 7" blade for epoxy. For proper removal of hardwood flooring (parkay laminated, plank laminated, plank solid) flooring must be scored to blade width. A ripping guide attached to the saw can be used to eliminate chalk line marks. Open an area large enough to fit machine or start from a doorway. It is important to keep all debris cleaned up for maximum performance of machine. True Parkay flooring scoring is not necessary. It will come up in small pieces.

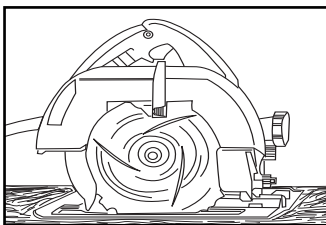

(A)

Scoring is done by using a circular saw set at a depth of 99% of the thickness of the board, just missing the subfloor surface when on concrete. A chalk line for scoring lines can be used across the floor the width of the blade.



WARNING

Never remove flooring containing asbestos without fully understanding proper state and federal procedures and guidelines for removal of these products. Laws are different from state to state.

MAINTAINING EQUIPMENT

Keep equipment in good repair by adopting a regular maintenance program. Before use, examine the general condition of equipment. Inspect guards, switches, tool cord set and extension cord for damage. Check for loose screws, misalignment, binding of moving parts, improper mounting, broken parts and any other condition that may affect its safe operation. If abnormal noise or vibration occurs, turn the tool off immediately and have the problem corrected before further use. Do not use a damaged tool. Tag damaged tools "DO NOT USE" until repaired. See Repairs.

- Mechanical inspection
- Cleaning (pulleys, spindles, bearings, housing, etc.)
- Electrical inspection (switch, cord, plugs, etc.)
- Testing to assure proper mechanical and electrical operation
- Check nuts on shock absorbers and bottom plate for tightness
- Check screws on bottom bearing for tightness
- Check all screws and fittings for a tight and secure fit
- Keep a sharp blade in machine for optimum performance

CLEANING

Clean dust and debris from vents. Keep the Equipment handle clean, dry and free of oil or grease. Use only mild soap and a damp cloth to clean since certain cleaning agents and solvents are harmful to plastics and other insulated parts. Some of these include: gasoline, turpentine, lacquer thinner, paint thinner, chlorinated cleaning solvents, ammonia and household detergents containing ammonia. Never use flammable or combustible solvents around tools. Machine is pressure washable. Make sure machine is dry before operation.

REPAIRS

If your tool is damaged, contact MK Diamond for a return authorization number and return the entire tool.

- Shipments are not accepted without a return authorization number.
- COD or freight collect shipments will not be accepted.

TROUBLESHOOTING

THERE IS NO POWER

1. Inspect electrical cord.

MOTOR NOISE

1. Make sure fan guard is not bent.

RATTLING

1. Tighten loose nuts and bolts.

MACHINE IS HARD TO HANDLE

1. Remove the counterweight.
2. Change to a smaller blade.
3. Sharpen blade.

BLOWS FUSES OR CIRCUIT BREAKERS

1. Check and/or change attached power cord. Use a 12 gauge cord, 50' or less.
2. Move to a different outlet or a better circuit.

WHEEL ADJUSTMENT WON'T WORK

1. Grease threaded shaft.

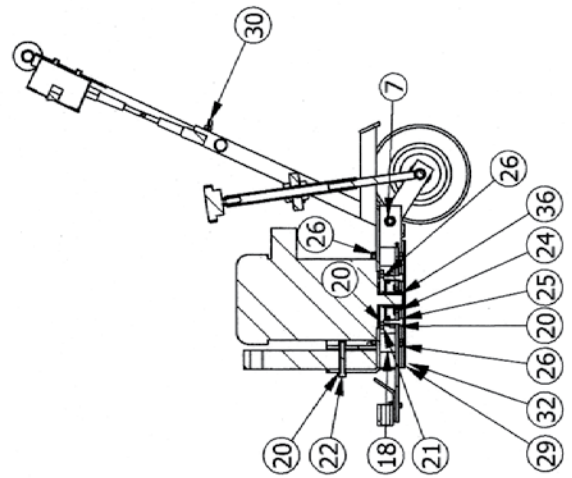
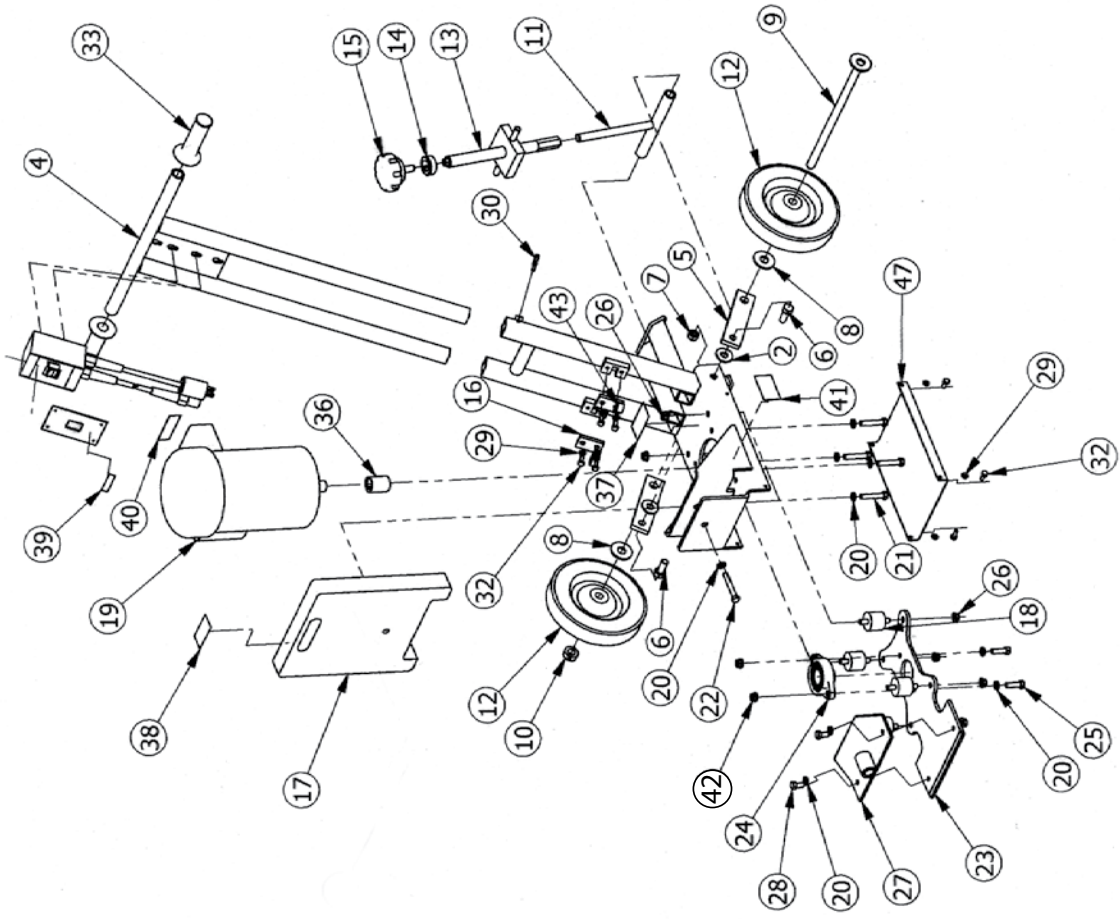

ITEM NO.	DESCRIPTION	PART OR IDENTIFYING NO.	QTY. REQ.
1	CHASSIS/MK-VTS/50	PG-10128	1
2	WASHER/FLAT 1/2" GB STL	500160	2
3	PIVOT PLATE ASSEMBLY/MK-VTS/50	PG-10126	1
4	HANDLE WELDMENT / MK-VTS/50	PG-10131	1
5	WHEEL LEG	06-500-25	2
6	SCR/CAP HEX 1/2"-13 X 1.25"	5002200	2
7	1/2"-13 NYLOX NUT	05-78108	2
8	WASHER/FLAT 5/8" GB	5001070	2
9	AXLE WELDMENT / MK-VTS/50	06-500-30	1
10	COLLAR, 1.13" OD X .625" ID X .50" WIDE	CP-10100	1
11	ADJUSTMENT T-BAR WELDMENT	06-550-4	1
12	8" REAR WHEEL, 8" OD X 5/8" HUB X 1-7/8" WIDE	06-500-29	2
13	ADJUSTMENT SHAFT WELDMENT/MK-VTS/50	PG-10127	1
14	COLLAR, 1-1/2" X 7/8" ID X .55" WIDE	CP-10099	1
15	AXLE ADJUSTMENT KNOB /MK-VTS/50	CP-10098	1
16	PIVOT BRKT COVER	06-550	2
17	FRONT COUNTER WEIGHT/MK-VTS/50	PA-10607	1
18	SHOCK ABSORBER/60 DURO NEOPRENE/MK-VTS/50	06-505-102	4
19	MOTOR/ELECTRIC 1HP, 60HZ	06-550-10	1
20	WASHER/LOCK 3/8"	5001150	9
21	SCR/CAP HEX 3/16" - 16 X 2.00" G5 STL	5002000	4
22	SCR/CAP HEX 0.375 - 16 X 1.000 G5 STL	800771	1
23	CUTTING HEAD / MK-VTS/50	PA-10622	1
24	FLANGE BEARING / 2 BOLT	06-5280-6	1
25	SCR/CAP HEX .375 -16 X 1.250" G5 STL	5007680	2
26	NUT, HEX, SFL, 5/16 - 18	5000810	8
27	TOOL HOLDER WELDMENT / MK-VTS/50	PG-10130	1
28	SCR/CAP HEX .375 - 16 X .75" GS STL	5001190	2
29	WASHER/LOCK 1/4"	500930	7
30	.375 - 16 X 1.00" THUMB SCREW FLT POINT	800766	2
32	SCR/CAP HEX .250 - 20 X .625" G5 STL	5001730	8
33	HANDLE/GRIP 4.5 LONG X 7/8: ID	P004024	2
34	PANEL/ELEC. CONTROL - MK-VTS/50 120V/60HZ	P004942	1
35	PLATE, SWITCH COVER PLATE / MK-VTS/50	PA-10544	1
36	ECCENTRIC / MK-VTS/50	06-550-101	1
37	PLATE/SERIAL-NUMBER USF/SAWTEC	05-55501	1
38	DECAL/WARNING-EYE AND EAR PROTECTION	05-65643	1
39	DECAL / 120 VOLT	05-65647	1
40	DECAL/ DO NOT USE EQUIPMENT TO FILTER	P004118	1
41	DECAL/MADE IN USA	P001420	2
42	NUT, HEX, CL, 3/8 - 16	153522	2

ITEM NO.	DESCRIPTION	PART OR IDENTIFYING NO.	QTY. REQ.
43	VINYL COATED LOOP STRAP FOR 1/2" OD	800756	2
44	MANUAL-MK-VTS/50	167790	1
45	30L X 16W X 19.5H DBL WALL W/HANDLES SHIPPING BOX	CP-10122	1
46	TUBE/MANUAL	P003235	1
47	BOTTOM COVER / MK-VTS/50	PA-10599	1

ORDERING INFORMATION

You may order MK Diamond products through your local MK Diamond distributor or, you may order direct from MK Diamond.

When ordering direct from MK Diamond, please have the following information ready before calling:

- The Model Number of the saw
- The Serial Number of the saw
- Where the saw was purchased and when
- The Part Number for the part(s) being ordered
- The Part Description for the part(s) being ordered

NOTE: There is a \$25.00 minimum order when ordering direct from MK Diamond. A \$5.00 charge will be added to orders having a net billing value under \$50.00. All purchases must be made using VISA, MasterCard or American Express.

All parts may be ordered by calling toll free to – 800 421-5830 or 310 539-5221 and asking for Customer Service. For technical questions, call – 800 474-5594.

RETURN MATERIALS POLICY

To expedite the service relative to the return of a product purchased through MK Diamond, please observe the following:

NOTE: When returning all items, they must have been purchased within the previous twelve (12) months.

- Have the Model Number of the saw
- Have the Serial Number of the saw
- Have the location of where the saw was purchased
- Have the date when the saw was purchased
- Contact Customer Service for approval to return the item(s)
- Obtain a Returned Goods Number (RGA) authorizing the return
- Follow the packaging instructions in the following section
- Ensure your item(s) are prepaid to the destination

For returned items, call toll free to – 800 421-5830 or 310 539-5221 and ask for Customer Service. For technical questions, call – 800 474-5594 or 310 257-2845.

PACKAGING INSTRUCTIONS

- Dry the Floor Scraper before shipping
- When packing, include the following: MK-VTS/50 Floor Scraper, nose weight and handle.
- Package the unit in its original container or one of comparable size (do not ship the unit partially exposed)
- Ensure all parts are secured in the packaging to prevent moving

AUTHORIZED SERVICE CENTERS

For quicker repair time, you may contact MK Diamond Customer Service, toll free, at 800 421-5830 or 310 539-5221 for the Authorized Service Center closest to you or visit our web site at www.mkdiamond.com. For technical questions, call – 800 474-5594.

CONTACT:

Please contact MK Diamond Products, Inc. Customer Service Department with any questions you might have regarding distributors, parts or service.

Telephone: **(800) 421-5830**

Fax: **(310) 539-5158**

E-mail: **Customer_Service@MKDiamond.com**

Customer Service Hours: **Monday through Friday, 6AM-4PM PST**

MK Diamond Products, Inc.

1315 Storm Parkway

Torrance, CA 90501

MK DIAMOND PRODUCTS, INC. LIMITED WARRANTY

MK DIAMOND PRODUCTS, INC. will guarantee every machine they build, to be free from defects in material and workmanship for (1) one year from date of purchase. The obligation of MK DIAMOND PRODUCTS, INC. under this warranty is limited to the repair or replacement of any parts which, under normal use, prove to be defective in material or workmanship. The parts involved or the unit in question should be returned to MK DIAMOND PRODUCTS, INC. or to a point designated by us, transportation prepaid.

This warranty does not obligate us to bear the cost of labor or transportation charges in connection with replacement or repair of defective parts. Likewise, it shall NOT apply to any unit which has been subjected to misuse, neglect or accident. This warranty does NOT apply to any machine which has been repaired or altered outside our factory.

This warranty does NOT obligate MK DIAMOND PRODUCTS, INC., with respect to items not of our manufacture, such as engines, motors, hydraulics, etc., which are subject to their own guarantees and warranties.

We shall in no event be liable for consequential damages or contingent liabilities arising out of failure of any equipment or parts to operate properly.

© COPYRIGHT 2011, MK DIAMOND PRODUCTS, INC. ALL RIGHTS RESERVED.

The MK Diamond logo is a registered trademark of MK Diamond Products, Inc. and may not be used, reproduced, or altered without written permission. All other trademarks are the property of their respective owners and used with permission.

MK Diamond may have patents, patent applications, trade marks, copyrights of other intellectual property right covering this product in this document.

This manual MUST accompany the equipment at all times. This manual is considered a permanent part of the equipment and should remain with the unit if resold.

The information and specifications included in this publication were in effect at the time of approval for printing.

MK-VTS/50 FLOOR SCRAPER
OWNERS MANUAL & OPERATING INSTRUCTIONS



MK Diamond Products, Inc.

MK Diamond Products, Inc.
1315 Storm Parkway
Torrance, CA 90501

Toll-Free: (800) 421-5830
Phone: (310) 539-5221
Fax: (310) 539-5158
www.mkdiamond.com