

# MK-370EXP TILE SAW

## OWNERS MANUAL, PARTS LIST & OPERATING INSTRUCTIONS



Revision 303	09.2011
Manual Part No. 160084	

**Caution:** Read all safety and operating instructions before using this equipment. This owners manual **MUST** accompany the equipment at all times.

## INTRODUCTION

Congratulations on your purchase of a MK-370EXP Saw Tile Saw. We are certain that you will be pleased with your purchase. MK Diamond takes pride in producing the finest construction power tools and diamond blades in the industry.

Operated correctly, your MK-370EXP Saw should provide you with years of service. In order to help you, we have included this manual. This owners manual contains information necessary to operate and maintain your MK-370EXP Saw safely and correctly. Please take a few minutes to familiarize yourself with the MK-370EXP Saw by reading and reviewing this manual.

If you should have questions concerning your MK-370EXP Saw, please feel free to call our friendly customer service department at: 800 421-5830

Regards,

MK Diamond

### NOTE THIS INFORMATION FOR FUTURE USE:

<b>MODEL NUMBER:</b>	
<b>SERIAL NUMBER:</b>	
<b>PURCHASE PLACE:</b>	
<b>PURCHASE DATE:</b>	

NOTE: For your (1) one year warranty to be effective, complete the warranty card (including the Serial Number) and mail it in as soon as possible.

## TABLE OF CONTENTS

### **SAFETY**

Safety Messages	4
Damage Prevention Message	4
General Safety Precautions	4
Rules for Safe Operation	4-5
California Proposition 65 Message	6
Hazard Symbols	7
Electrical Requirements	8-10
Safety Label Locations	11
Product Specifications	12

### **UNPACKING, TRANSPORT and ASSEMBLY**

Unpacking	13
Contents	13
Transport	13

### **STARTUP, ADJUSTMENT, OPERATION and SHUTDOWN**

Cutting Head Installation	14
Diamond Blade Installation	14-15
Adjustable Cutting Guide Installation	16
Splash Guard Installation	16
Pre-Start Inspection	17
Water Pump Preparation	17-18
Setup for Operation	19
Operation	20-24
Cleanup	25

### **MAINTENANCE AND TROUBLESHOOTING**

Maintenance	27-28
Flow adjustment	28
Blade Dressing	29
Diamond Blade Change-Out	30
Troubleshooting	31-38

### **EXPLODED VIEW AND PARTS LIST**

Exploded View & Parts List	40-45
----------------------------	-------

### **ACCESSORIES ORDERING and RETURN INSTRUCTIONS**

Accessories	46
Ordering Information	47
Return Material Policy	47
Packaging Instructions	47
Authorized Service Centers	47

Read and follow all safety, operating and maintenance instructions. Failure to read and follow these instructions could result in injury or death to you or others. Failure to read and follow these instructions could also result in damage and/or reduced equipment life.

## SAFETY MESSAGES

---

A safety message alerts you to potential hazards that could hurt you or others. Each safety message is preceded by a safety alert symbol (  ) and one of three words: **DANGER**, **WARNING**, or **CAUTION**.



**DANGER** You **WILL** be **KILLED** or **SERIOUSLY INJURED** if you do not follow directions.



**WARNING** You **CAN** be **KILLED** or **SERIOUSLY INJURED** if you do not follow directions.



**CAUTION** You **CAN** be **INJURED** if you do not follow directions. It may also be used to alert against unsafe practices.

## DAMAGE PREVENTION AND INFORMATION MESSAGES:

A Damage Prevention Message is to inform the user of important information and/or instructions that could lead to equipment or other property damage if not followed. Information Messages convey information that pertains to the equipment being used. Each message will be preceded by the word **NOTE**, as in the example below.

**NOTE:** Equipment and/or property damage may result if these instructions are not followed.

## GENERAL SAFETY PRECAUTIONS AND HAZARD SYMBOLS

In order to prevent injury, the following safety precautions and symbols should be followed at all times!

## SAFETY PRECAUTIONS

---



**ALWAYS** read this Owner's Manual before operating the machine.



**ALWAYS** keep the Blade Guards in place.



### REMOVE ADJUSTING KEYS AND WRENCHES

Form a habit of checking to see that keys and adjusting wrenches are removed from the power tool before it is turned on.



### KEEP WORK AREA CLEAN

Cluttered work areas and benches invite accidents.



### DO NOT USE IN DANGEROUS PLACES

**DO NOT** use power tools in damp or wet locations nor expose them to rain. Always keep the work area well lighted.



### KEEP CHILDREN AWAY

All visitors and children should be kept a safe distance from work area.

**MAKE THE WORKSHOP KID PROOF**

Make the workshops kid proof by using padlocks, master switches or by removing starter keys.

**DO NOT FORCE THE TOOL**

A power tool will do a job better and safer operating at the rate for which it was designed.

**USE THE RIGHT TOOL**

**DO NOT** force a tool or an attachment, to do a job that it was not designed to do.

**USE THE PROPER EXTENSION CORD**

If using an extension cord make sure it is in good condition first. When using an extension cord, be sure to use one heavy enough to carry the current your product will draw. An undersized cord will cause a drop in line voltage that will result in a loss of power and overheating. TABLE 1, Page 10 shows the correct AWG size to use depending on cord length and nameplate ampere rating. If in doubt, use the next heavier gage. The smaller the gage number, the heavier the cord.

**USE PROPER APPAREL**

**DO NOT** wear loose clothing, gloves, neckties, rings, bracelets, or other jewelry that may be caught in moving parts. Non-slip footwear is recommended. Wear protective hair covering to contain long hair.



**ALWAYS** wear approved eye protection.



**ALWAYS** wear approved respiratory protection.

**SECURE WORK**

Clamps or a vise should be used to hold work whenever practical. Keeping your hands free to operate a power tool is safer.

**DO NOT OVERREACH**

Keep proper footing and balance at all times by not overreaching.

**MAINTAIN TOOLS WITH CARE**

Keep tools clean for the best and safest performance. Always follow maintenance instructions for lubricating, and when changing accessories.

**DISCONNECT TOOLS**

Power tools should always be disconnected before servicing or when changing accessories, such as blades, bits, cutters, and the like.



**ALWAYS** place the power ON/OFF switch in the **OFF** position when the saw is not in use.

**USE RECOMMENDED ACCESSORIES**

Consult the owner's manual for recommended accessories. Using improper accessories may increase the risk of personal or by-stander injury.

**NEVER STAND ON THE TOOL**

Serious injury could occur if a power tool is tipped, or if a cutting tool is unintentionally contacted.

**CHECK FOR DAMAGED PARTS**

Before using a power tool, check for damaged part. A guard or any other part that is damaged should be carefully checked to determine if would operate properly and perform its intended function. Always check moving parts for proper alignment or binding. Check for broken parts and mountings and all other conditions that may affect the operation of the power tool. A guard, or any damaged part, should be properly repaired or replaced.

**DIRECTION OF FEED**

**ALWAYS** feed work into a blade or cutter against the direction of rotation. A blade or cutter should always be installed such that rotation is in the direction of the arrow imprinted on the side of the blade or cutter.

**NEVER LEAVE A TOOL UNATTENDED**

**TURN POWER OFF** - Do not leave a tool until it comes to a complete stop. Always turn a power tool OFF when leaving the work area, or, when a cut is finished.

---

**CALIFORNIA PROPOSITION 65 MESSAGE****WARNING**

Some dust created by power sanding, sawing, grinding, drilling, and other construction activities contain chemicals known [to the State of California] to cause cancer, birth defects or other reproductive harm. Some examples of these chemicals are:

- Lead, from lead-based paints
- Crystalline silica, from bricks and cement and other masonry products and
- Arsenic and chromium, from chemically treated lumber

For further information, consult the following sources:

<http://www.osha.gov/SLTC/silicacrystalline/index.html>

[http://www.oehha.org/prop65/out\\_of\\_date/6022kLstA.html](http://www.oehha.org/prop65/out_of_date/6022kLstA.html)

Your risk from these exposures varies depending on how often you do this type of work. To reduce your exposure to these chemicals, work in a well-ventilated area, and work with approved safety equipment, such as those dust masks that are specially designed to filter out microscopic particles.

**HAZARD SYMBOLS**

---

**ELECTRICAL SHOCK**

**NEVER** touch electrical wires or components while the engine is running. They can be sources of electrical shock which could cause severe injury or burns.

**ROTATING PARTS**

Keep hands, feet, hair, and clothing away from all moving parts to prevent injury. Never operate the motor with covers, shrouds, or guards removed.

**OVER SPEED**

**NEVER** tamper with the governor components or settings to increase the maximum speed. Severe personal injury and damage to the engine or equipment can result if operated at speeds above maximum.

**DO NOT EXPOSE TO RAIN**

**DO NOT** expose to rain or use in damp locations.

**WARNING**

Sawing and drilling generates dust. Excessive airborne particles may cause irritation to eyes, skin and respiratory tract. To avoid breathing impairment, always employ dust controls and protection suitable to the material being sawed or drilled; See OSHA (29 CFR Part 1910.1200). Diamond Blades improperly used are dangerous. Comply with American National Standards Institute Safety Code, B7.1 and, Occupational Safety and Health Act covering Speed, Safety Guards, Flanges, Mounting Procedures, General Operating Rules, Handling, Storage and General Machine Conditions

## ELECTRICAL REQUIREMENTS AND GROUNDING INSTRUCTIONS

In order to prevent potential electrical shock and injury, the following electrical safety precautions and symbols should be followed at all times!



### WARNING

In case of a malfunction or breakdown, grounding provides a path of least resistance for electric current to reduce the risk of electric shock. This tool is equipped with an electric cord having an equipment-grounding conductor and a grounding plug. The plug must be plugged into a matching outlet that is properly installed and grounded in accordance with all local codes and ordinances.

- Do not modify the plug provided – if it will not fit the outlet; have the proper outlet installed by a qualified electrician
- Improper connections of the equipment-grounding conductor can result in a risk of electric shock. The equipment-grounding conductor is the insulated conductor that has an outer surface that is green, with or without yellow stripes. If repair or replacement of the electric cord or plug is necessary, do not connect the equipment-grounding conductor to a live terminal
- Check with a qualified electrician or service personnel if the grounding instructions are not completely understood, or if in doubt as to whether the tool is properly grounded
- Use only 3-wire extension cords that have 3-prong grounding plugs and 3-pole receptacles that accept the tool's plug
- Repair or replace a damaged or worn cord immediately



### WARNING

This tool is intended for use on a circuit that has an outlet that looks like the one shown in Sketch A. The tool has a grounding plug that looks like the plug illustrated in Sketch A. A temporary adapter, which looks like the adapter illustrated in sketches B and C, may be used to connect this plug to a 2-pole receptacle as shown in Sketch B, if a properly grounded outlet is not available. The temporary adapter should be used only until a properly grounded outlet can be installed by a qualified electrician. The green-colored rigid ear, lug, and the like, extending from the adapter, must be connected to a permanent ground such as a properly grounded outlet box.

NOTE: Use of a temporary adapter is not permitted in Canada.

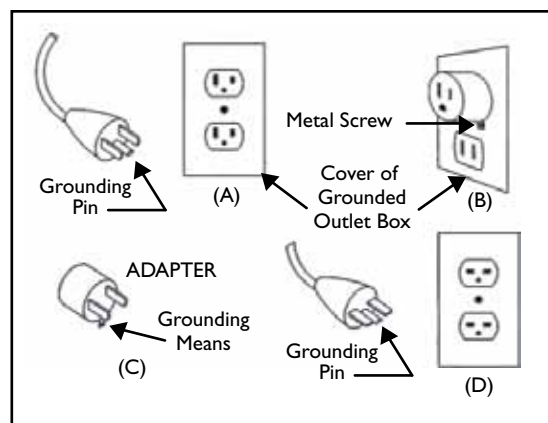

Circuit and Adapter Information



**WARNING**

To avoid the possibility of the appliance plug or receptacle getting wet, position the machine to one side of a wall mounted receptacle. This will prevent water from dripping onto the receptacle or plug. A “drip loop,” shown in the picture below, should be arranged by the user to properly position the power cord relative to the power source.

The “drip loop” is that part of the cord below the level of the receptacle, or the connector, if an extension cord is used. This method of positioning the cord prevents the travel of water along the power cord and coming in contact with the receptacle.

If the plug or receptacle gets wet, **DO NOT** unplug the cord. Disconnect the fuse or circuit breaker that supplies power to the tool. Then unplug and examine for presence of water in the receptacle.

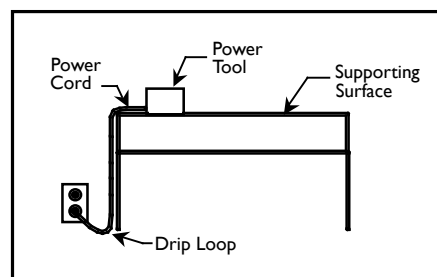

**Drip Loop Information**

**WARNING**

Use only extension cords that are intended for outdoor use. These extension cords are identified by a marking “Acceptable for use with outdoor appliances; store indoors while not in use.” Use only extension cords having an electrical rating not less than the rating of the product. Do not use damaged extension cords. Examine extension cords before using and replace if damaged. Do not abuse extension cords and do not yank on any cord to disconnect. Keep cords away from heat and sharp edges. Always disconnect the extension cord from the receptacle before disconnecting the product from the extension cord.



**WARNING**



To reduce the risk of electrocution, keep all connections dry and off the ground. Do not touch the plug with wet hands.



**WARNING**

Use of under sized extension cords result in low voltage to the motor that can result in motor burnout and premature failure. MK Diamond warns that equipment returned to us showing signs of being run in a low voltage condition, through the use of undersized extension cords will be repaired or replaced totally at the customer's expense. There will be no warranty claim.

To choose the proper extension cord,

- Locate the length of extension cord needed in the table below.
- Once the proper length is found, move down the column to obtain the correct AWG size required for that length of extension cord.

EXTENSION CORD MINIMUM GAGE FOR LENGTH				
VOLTS	TOTAL LENGTH OF CORD IN FEET			
	25 ft. AWG	50 ft. AWG	100 ft. AWG	150 ft. AWG
115v	14	12	Not Recommended	Not Recommended
230v	N/A	14	12	N/A

**SAFETY LABEL LOCATIONS**

Safety labels contain important safety information. Please read the information contained on each safety label. These labels are considered a permanent part of your saw. If a label comes off or becomes hard to read, contact MK Diamond or your dealer for a replacement.

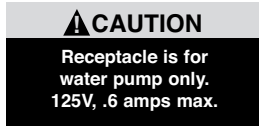

Label A



Label B



Label C

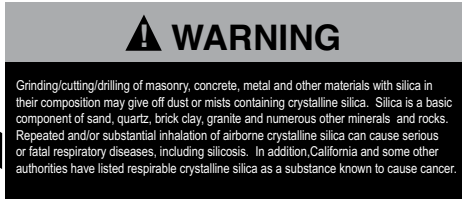

Label D

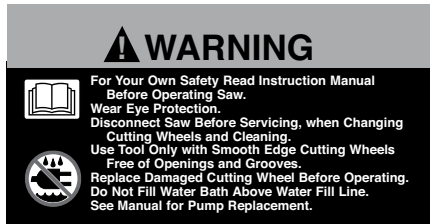

Label E

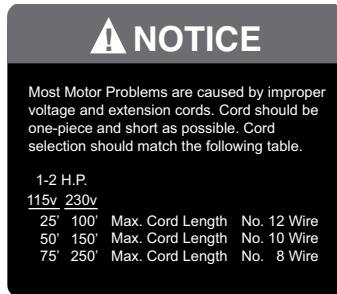

Label F

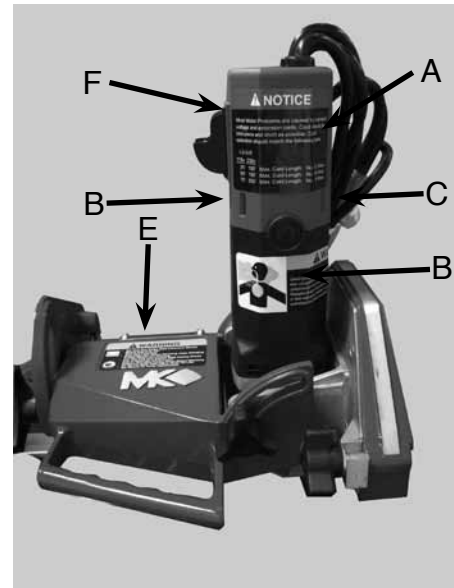

Tile Master Label Sheet Part#166012

Decal/Label	Location	Description
A	Motor - Side	Caution - Receptacle is for Water Pump Only
B	Motor - Side	Caution - Use with GFCI outlet only
C	Motor - Back	Service/ Warranty
D	Motor - Front	Warning - Silica Warning
E	Cutting Head – Top	Warning - Read Owners Manual
F	Motor - Front	Notice - Voltage/extension cords

**TILE SAW SPECIFIC WARNINGS**

**WARNING**

- Wear eye protection.
- Use splash guard for every operation for which it can be used.
- Disconnect saw before servicing, when changing cutting blades, and cleaning.
- Replace damaged cutting blade before operating.

## **PRODUCT SPECIFICATIONS**

---

The MK-370EXP Saw is a versatile Tile Saw. Operated and used according to this manual, the MK-370EXP Saw will provide years of dependable service.

## **GENERAL DESCRIPTION**

---

The MK-370EXP Saw Tile Saw is engineered as a tabletop or stand mounted wet tile saw. The saw includes a powerful 120v electric motor. The saw is capable of cutting tile up to eighteen (18) inches in length. The saw can cut an object two (2) inches thick in one pass.

## **MOTOR SPECIFICATIONS**

---

Motor specifications for the MK-370EXP Saw are listed in the table below.

Voltage	120v
Overall Amperage	7.4 A
Frequency	50/60Hz
RPM	6000 rpm
Horse Power	1-1/4 hp

## **BLADE CAPACITY**

---

The MK-370EXP Saw uses a seven (7) inch (178mm) diameter, wet cutting continuous rim, MK Diamond blade with a five-eighths (5/8) inch (15.875 mm) arbor.

## **TILE TYPES**

---

The MK-370EXP Saw can cut a variety of tile types including stone, ceramic, slate, granite, marble, porcelain, and lapidary products.

**NOTE:** The MK-370EXP Saw is not designed to cut plastic or metals.

**UNPACKING**

**⚠ CAUTION** Use proper lifting techniques when lifting the MK-370EXP Saw  
Remove the MK-370EXP Saw and accessory box from the carton.

**CONTENTS:**

One (1) MK-370EXP cutting surface & water pan  
One (1) MK-370EXP cutting head  
One (1) 7-inch wet cutting blade  
One (1) splash guard  
One (1) splash guard wing nut & washer

One (1) extended rip guide  
One (1) electric water pump  
One (1) pump discharge fitting  
One (1) cooling transfer tube  
One (1) Flow adjusting clamp

One (1) shaft wrench,  
One (1) owners manual  
One (1) pump manual  
One (1) warranty card

One (1) blade wrench

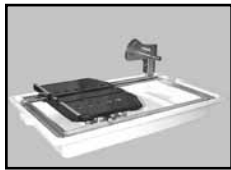

MK-370EXP  
Cutting Surface



MK-370EXP  
Cutting Head



Diamond Blade

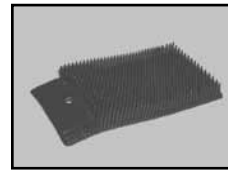

Splash Guard



Splash Guard  
Wing Nut & Washer



Extended  
Rip Guide



Electric  
Water Pump



Pump  
Discharge Fitting



Cooling  
Transfer Tube



Flow  
Adjusting Clamp



Blade Nut  
Wrench



Shaft  
Wrench



Owners  
Manual



Pump  
Manual



Warranty  
Card

**TRANSPORT**

- ⚠ CAUTION**
1. The MK-370EXP Saw weighs approximately thirty-three (33) pounds; use care when transporting.
  2. Never transport the MK-370EXP Saw with water in the Water Pan.

The MK-370EXP Saw is designed with a rigid frame and removable Cutting Head making the saw easily transportable. To lift the saw, grasp the front and back of the frame at the lift points shown below.

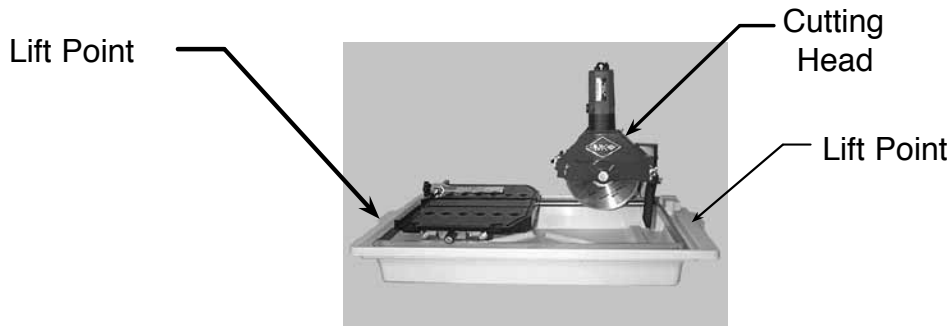

Follow the assembly instructions to prepare your MK-370EXP Saw for operation.

**CUTTING HEAD INSTALLATION**

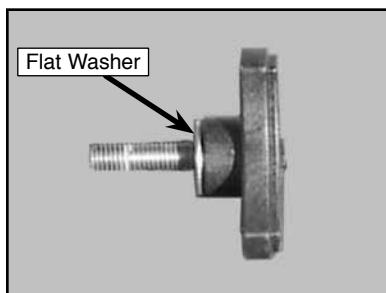

(A)  
Place the Flat Washer onto the Height Adjusting Knob

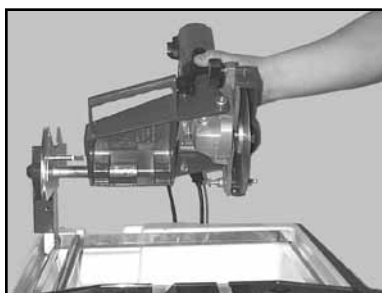

(B)  
Align Cutting Head Pivot Hole to the Post, Pivot Shaft



(C)  
Verify the Cutting Head is completely installed and seated on the Post

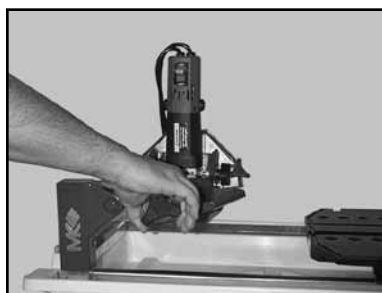

(D)  
Install the Height Adjusting Knob through the Post into the Cutting Head and tighten the Knob

**DIAMOND BLADE INSTALLATION**

**NOTE:** When installing the Retaining Screw, do not "cross-thread" and DO NOT over tighten the screw.

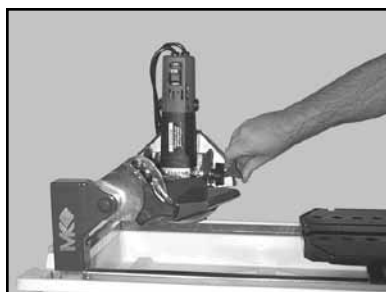

(A)  
Loosen and remove the Blade Guard Retaining Knob



(B)  
Loosen the Blade Guard Retaining Wing nut



(C)  
Open the Blade Guard

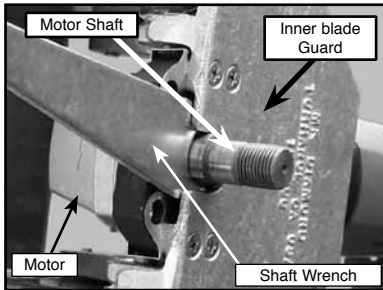

(D)  
Place the Shaft Wrench between the Inner Blade Guard and the Motor and onto the Motor Shaft

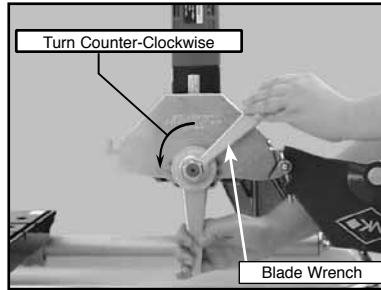

(E)  
Using the Blade and Shaft Wrenches, loosen and remove the Retaining Nut and Outer Flange

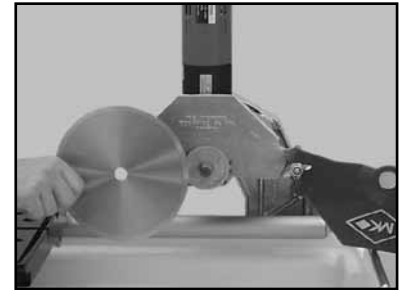

(F)  
Install Diamond Blade onto Blade Shaft



(G)  
Install the Retaining Nut and Outer Flange and then tighten using the Blade and Shaft Wrenches

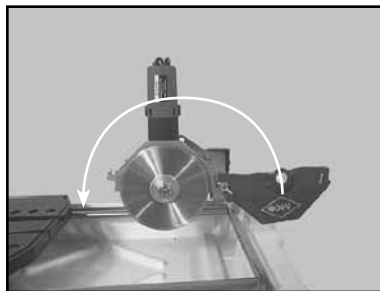

(H)  
Close the Blade Guard

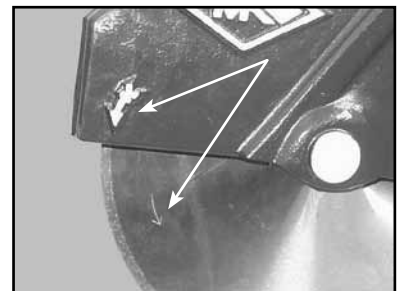

(I)  
Verify the Blade is seated on the Blade Shaft and direction of rotation is correct

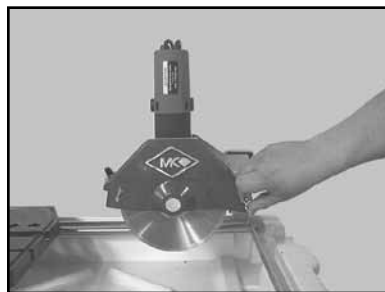

(J)  
Tighten the Blade Guard Retaining Wing nut



(K)  
Tighten the Blade Guard, Retaining Knob

## ADJUSTABLE CUTTING GUIDE INSTALLATION

NOTE: The Adjustable Cutting Guide can be used on either side of the Diamond Blade.

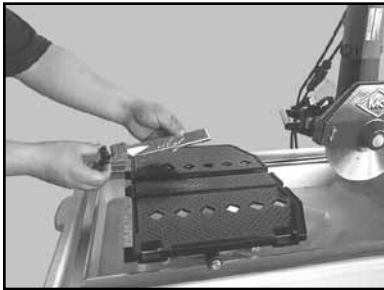

(A)  
Loosen Adjustable Cutting Guide retaining thumbscrew and place it over the Movable Cutting Table, Ruler/Stop

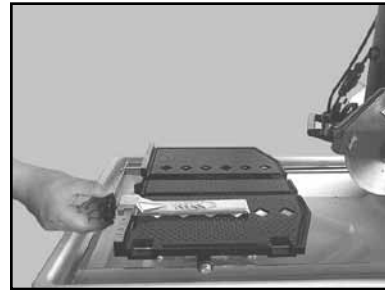

(B)  
Place the Adjustable Cutting Guide onto the Movable Cutting, Table Ruler/Stop and tighten the retaining thumbscrew

## SPLASH GUARD INSTALLATION

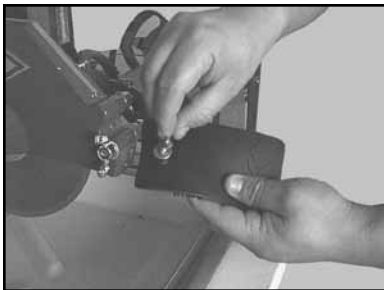

(A)  
Install the retaining thumbscrew through the washer and Splash Guard then align to the hole found on back of the Blade Guard



(B)  
Install the Splash Guard onto the Blade Guard

## WATER PUMP PREPARATION

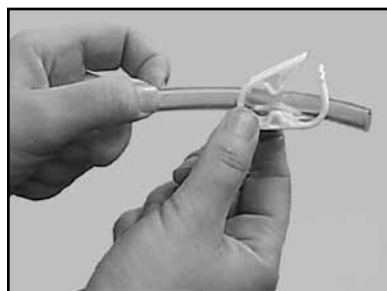

(A)  
Slide Cooling Flow Adjusting Clamp onto the Cooling Transfer Tube



(B)  
Press one end of the Cooling Transfer Tube onto the Water Pump Discharge Fitting



**PRE-START INSPECTION**

Prior to beginning work, a pre-start inspection of the saw should be performed.



(A)  
Ensure the ON/OFF Switch  
is in the OFF position

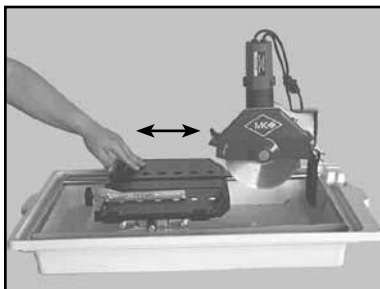

(B)  
Verify the Movable Cutting  
Table moves freely

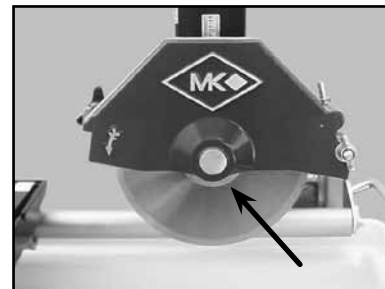

(C)  
Inspect the Diamond Blade for  
damage – verify the blade is  
correct for the type of material  
being cut



(D)  
Inspect the Pump Assembly  
for damage – ensure the cord  
is free of cracks or cuts



(E)  
Inspect the MK-370EXP  
Saw for damage – ensure  
the cord is free of cracks  
or cuts

**CONNECTING THE WATER PUMP****WARNING**

1. To prevent the possibility of electrical shock, the MK-370EXP Saw **MUST** be de-energized when connecting the Water Pump.
2. To prevent the possibility of electrical shock, use only MK Diamond authorized replacement parts.

**NOTE:** To prevent pump damage, the Water Pump must be disconnected if cutting dry.

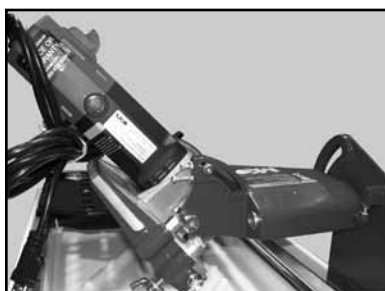

(A)  
Loosen the cutting head  
pivot retaining knob and tilt  
cutting head to 45°



(B)  
Connect the Cooling Transfer  
Tube to the inlet connection  
on the Blade Guard

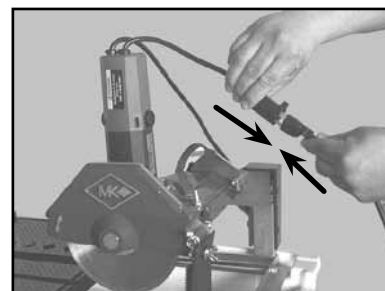

(C)  
Connect the Water Pump  
power cord to the connection  
found on the back of the motor

## **WATER PUMP SETUP FOR OPERATION**

The Water Pump can be setup for operation in two ways: External Water Source or Re-circulation.

**NOTE:** If cutting dry DO NOT connect the water pump.

## **RE-CIRCULATION**

**NOTE:** When using the re-circulation method, the water should be changed often for longer pump life

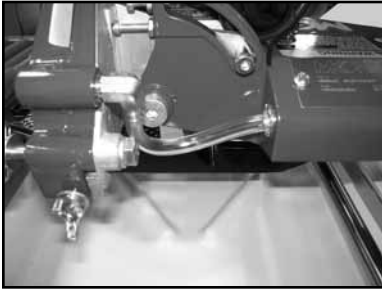

(A)  
Ensure that Cooling  
Transfer Tube is  
connected

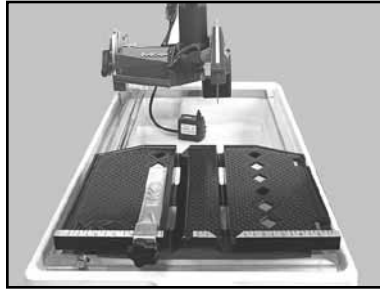

(B)  
Place the Water Pump  
toward the back of the  
Water Pan



(C)  
Position pump as shown  
and place the pump  
electrical cord and  
cooling transfer tube  
under the frame.

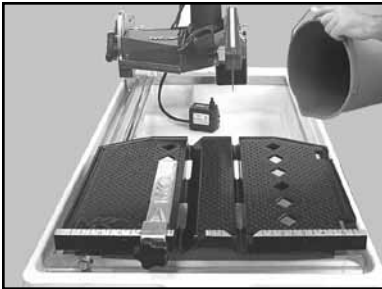

(D)  
Fill the Water Pan until  
water completely covers  
the Water Pump suction

## **EXTERNAL WATER SOURCE**

This is the preferred method of cooling.

1. Verify or remove the Drain Plug from the Water Pan.
2. Place the Water Pump in an external container.
3. Fill the external container until water completely covers the Water Pump suction inlet.
4. Place an external catch basin below the Water Pan drain hole.

**SETUP FOR OPERATION**

---

**CAUTION**

1. Before powering or starting, check for damage that could prevent this equipment from proper operation or performing its intended function. Check for binding and alignment of moving parts. Check for damaged, broken, or missing parts.
2. Verify the On/Off switch is in the OFF position.
3. Before connecting the MK-370EXP Saw to a power supply, be sure the voltage, cycle and phase of the job site power source meet the requirements of the table below.
4. Plug the MK-370EXP Saw into a wall outlet with built-in GFCI protection.
5. Do not cover the motor vents as this could lead to motor overheating.

VOLTAGE	120v
CYCLE	60Hz
PHASE	1-phase

- NOTE:** 1. If using an extension power cord, make sure the length and wire gauge correspond to the requirements listed in on page 10. An extension power cord that is too small in wire gauge (diameter), or too long in length, will cause the motor to overheat and could cause premature failure.

**CUTTING STRAIGHT EDGES**

**⚠ CAUTION** DO NOT FORCE THE TOOL. It will do the job better and safer at the rate for which it was designed.

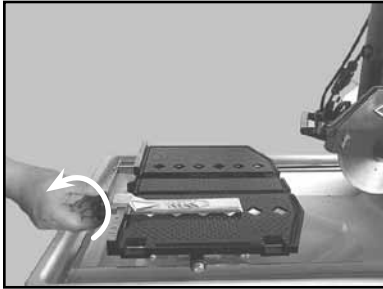

(A)  
Loosen the Adjustable Cutting Guide retaining thumbscrew

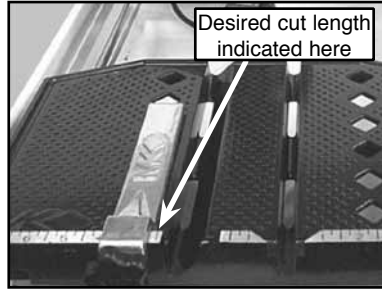

(B)  
Position the Adjustable Cutting Guide to desired cut length

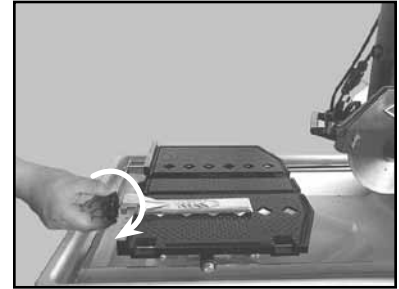

(C)  
Tighten the retaining thumbscrew

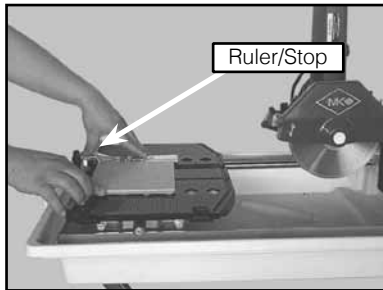

(D)  
Place the tile against the Ruler/Stop and Cutting Guide

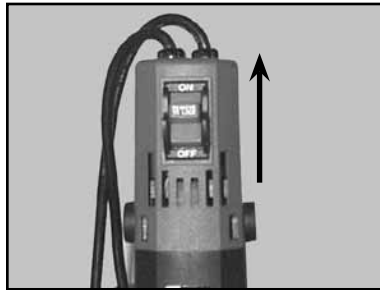

(E)  
Turn the motor ON

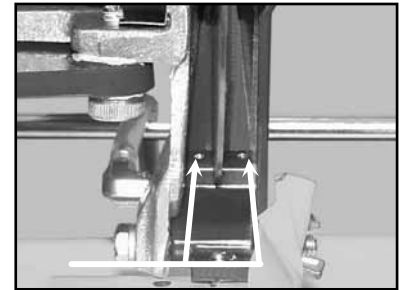

(F)  
Verify cooling flow on both sides of the blade

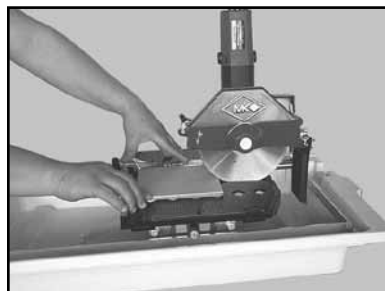

(G)  
Perform the cut



(H)  
Turn the motor OFF when work is complete

**CUTTING 45° MITERS**

The MK-370EXP Saw is designed with an adjustable Cutting Head for precision 45° Miter Cuts.

**⚠ CAUTION DO NOT FORCE THE TOOL.** It will do the job better and safer at the rate for which it was designed.

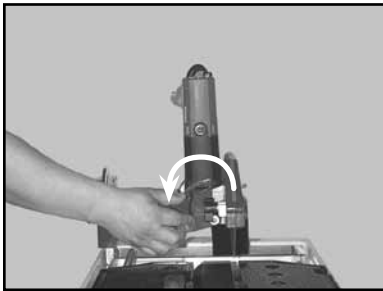

(A)  
Loosen the Cutting Head  
Pivot, Retaining Knob

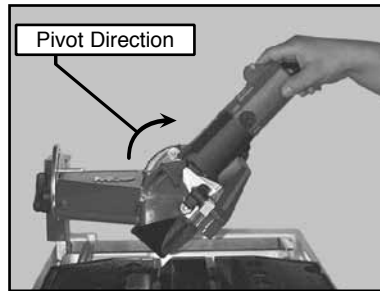

(B)  
Pivot the Cutting Head to  
the 45° cutting position

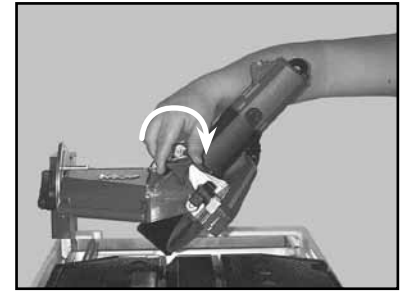

(C)  
Tighten the Cutting Head,  
Pivot Retaining Knob

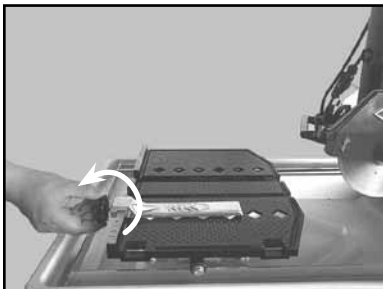

(D)  
Loosen the Adjustable  
Cutting Guide retaining  
thumbscrew



(E)  
Position the Adjustable  
Cutting Guide to desired  
cut length

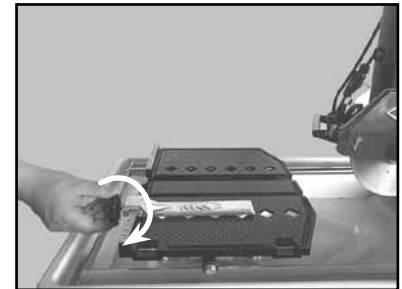

(F)  
Tighten the retaining  
thumbscrew

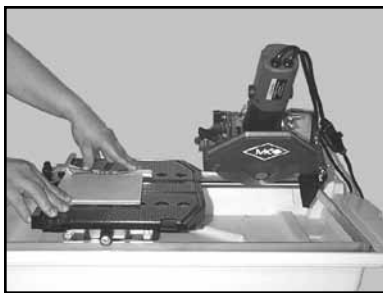

(G)  
Place the against the  
Ruler/Stop and Cutting  
Guide

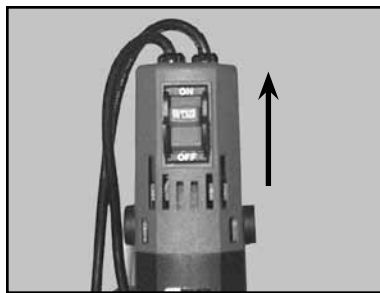

(H)  
Turn the motor ON

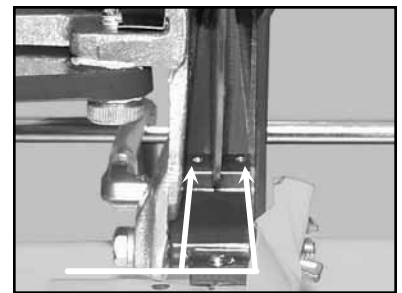

(I)  
Verify cooling flow on both  
sides of the blade

CUTTING 45° MITERS (CONT...)

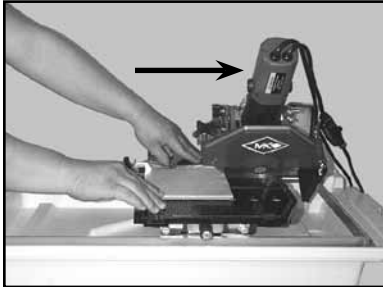

(J)  
Perform the cut

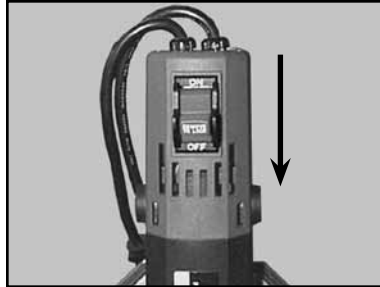

(K)  
Turn the motor OFF  
when work is complete

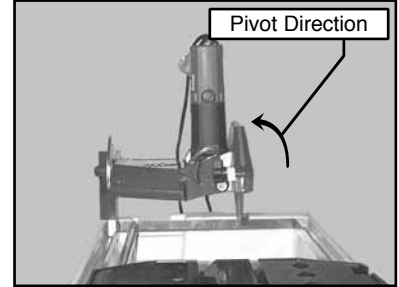

(L)  
Return the Cutting Head  
to the upright position  
when complete

**DIAGONAL CUTTING**

**NOTE:** To cut diagonal, the Dual 45° Flat Angle Guide (MK Diamond Part No. 134557-MK) should be used.

**! CAUTION DO NOT FORCE THE TOOL.** It will do the job better and safer at the rate for which it was designed.

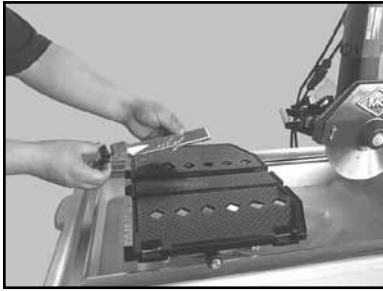

(A)  
Remove the Adjustable Cutting Guide

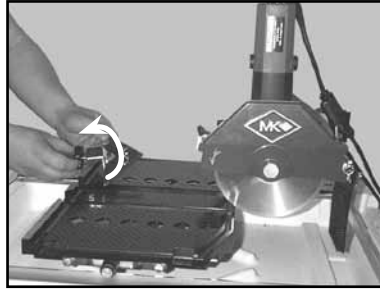

(B)  
Place the Dual 45° Flat Angle Guide on the Ruler/Stop

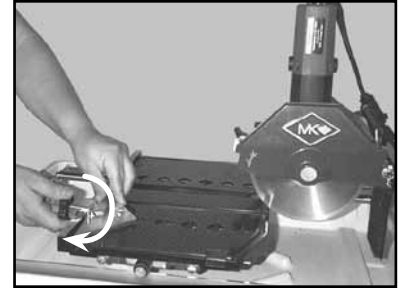

(C)  
Position the Dual 45° Flat Angle Guide and tighten the retaining knob

If Cutting the tile in two equal halves, align the tile in the V-notch of the Movable Cutting Table Ruler/Stop.

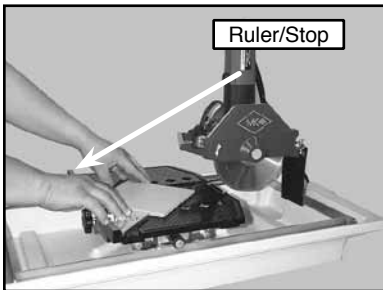

(D)  
Position the tile against the Dual 45° Flat Angle Guide and the Ruler/Stop



(E)  
Turn the motor ON

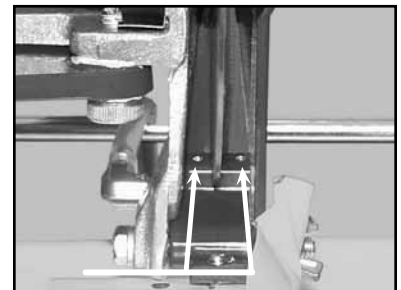

(F)  
Verify cooling flow on both sides of the blade

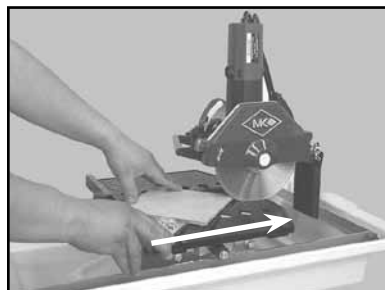

(G)  
Perform the cut



(H)  
Turn the motor OFF when work is complete

**OFF-ANGLE CUTTING**

**NOTE:** Use a Protractor (MK Part No. 134569-MK) to cut angles other than 45° angles. (not included)

**⚠ CAUTION DO NOT FORCE THE TOOL.** It will do the job better and safer at the rate for which it was designed.

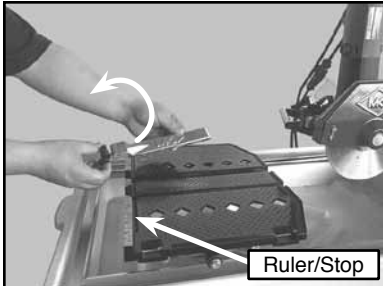

(A)  
Remove the Adjustable Cutting Guide

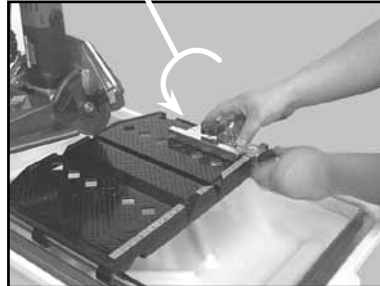

(B)  
Place the Protractor on the Ruler/ Stop. Turn CCW to loosen

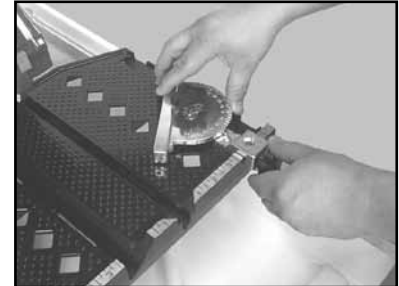

(C)  
Set the desired angle on the Protractor Gage

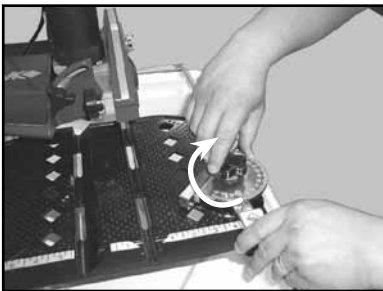

(D)  
Tighten the Protractor Gage retaining knob

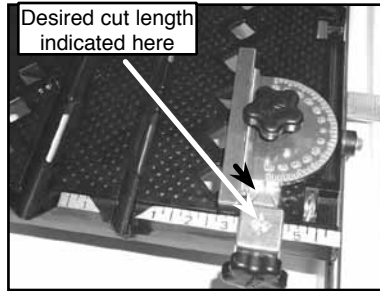

(E)  
Position the Protractor Cutting Guide to the desired length

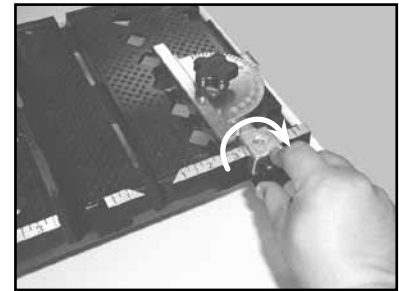

(F)  
Tighten the retaining knob

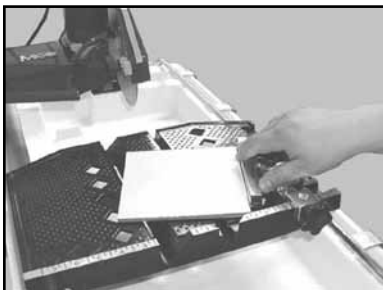

(G)  
Position the tile against the Protractor and the Ruler/Stop



(H)  
Turn the motor ON

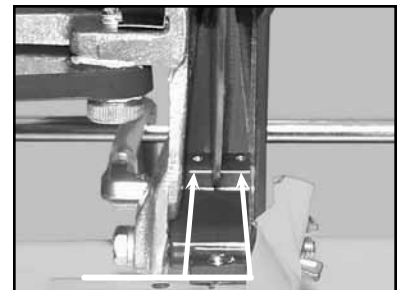

(I)  
Verify cooling flow on both sides of the blade



(G)  
Perform the cut

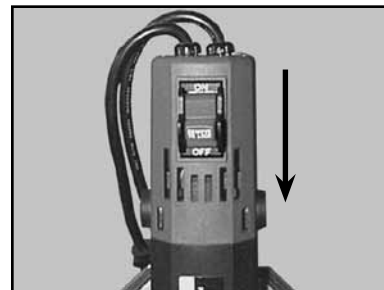

(H)  
Turn the motor OFF when work is complete



**CLEANUP**

**NOTE:** Dispose of wastewater in accordance with applicable Federal, State and Local laws.



(A)  
Remove the pump Suction Screen and clean the Water Pump of all debris.  
(See pump manual for more detail)

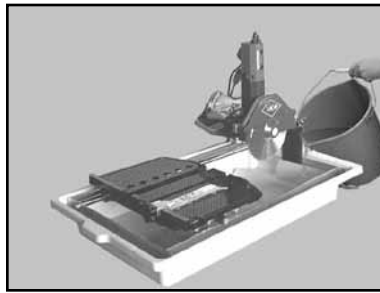

(B)  
Fill the Water Pan with clean water

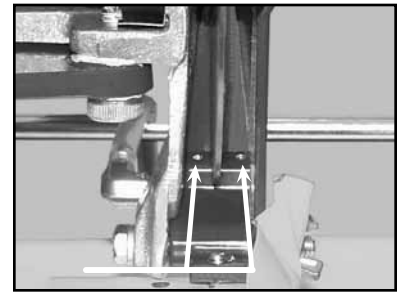

(C)  
Run the MK-370EXP Saw until clear water is seen at the blade Cooling Flow Points (Approx. 1 minute)



**CAUTION**

Ensure the saw is disconnected before completing the remainder of the cleanup process.



(D)  
Ensure the ON/OFF Switch is in the OFF position.  
Unplug the saw from the Power source



(E)  
Remove the Cutting Assembly from the Water Pan

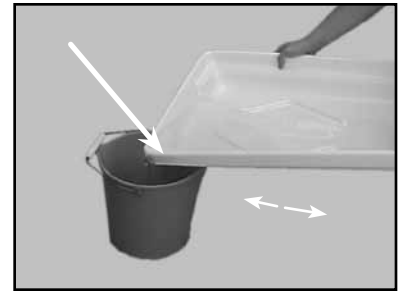

(F)  
Dispose the contents of the Water Pan



(G)  
Clean the MK-370EXP with soap and clean water

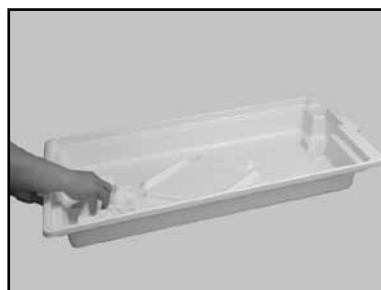

(H)  
Clean the Water Pan



(I)  
Clean the Adjustable Cutting Guide and Guide Bar

**! CAUTION** Ensure water is not forced into the motor casing when cleaning.



(J)  
Clean the Roller Wheel  
Guide Rail

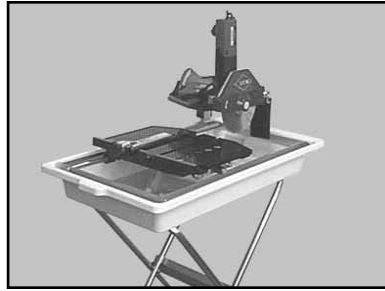

(K)  
Clean the remainder of the  
MK-370EXP Saw

**MAINTENANCE FOLLOWING USE**

To extend the life of the MK-370EXP Saw, the following procedure should be performed after each use. Lubricate all points listed below with light oils such as, 3 in 1, WD-40, etc.



(A)  
Ensure the ON/OFF Switch  
is in the OFF position

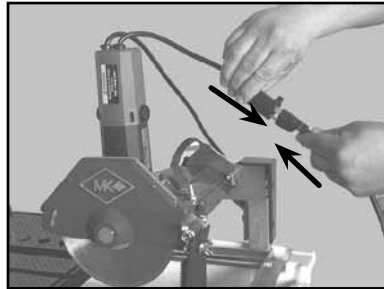

(B)  
Unplug MK-370EXP Saw

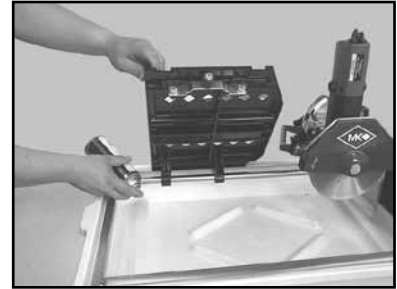

(C)  
Lubricate the Guide Bar

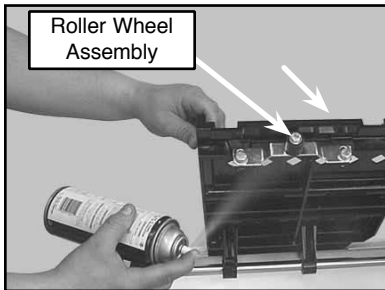

(D)  
Lubricate the Roller  
Wheel Assembly

**MONTHLY MAINTENANCE**

The following maintenance should be performed Monthly.

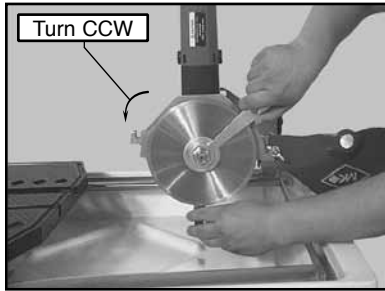

(A)  
Remove the Diamond  
Blade, Outer Flange and  
Retaining Nut

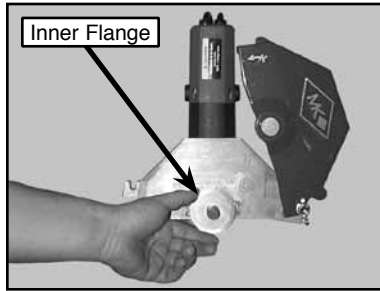

(B)  
Remove the Inner Flange

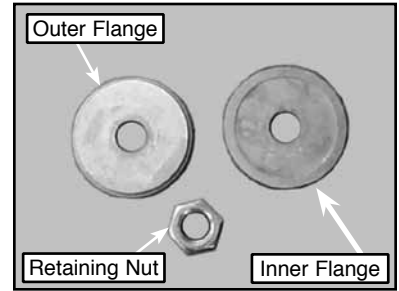

(C)  
Clean and Lubricate the  
Inner and Outer Flanges  
and the Retaining Nut



(D)  
Clean around Motor Shaft

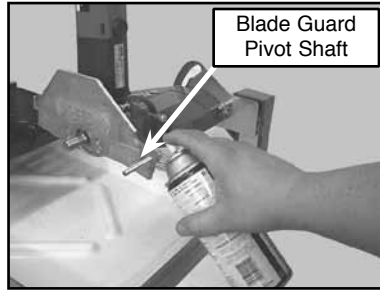

(E)  
Remove the Blade Guard  
then clean and lubricate the  
Blade Guard Pivot Shaft

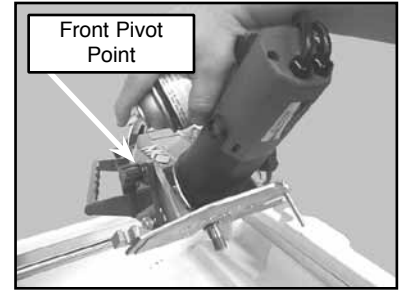

(F)  
Lubricate the front Cutting  
Head Pivot Point

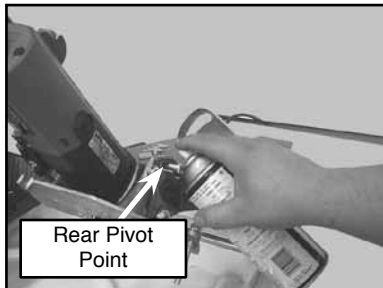

(G)  
Lubricate the rear Cutting  
Head Pivot Point



(H)  
Remove the Cutting Head



(I)  
Clean the Cutting Head  
Pivot Holes

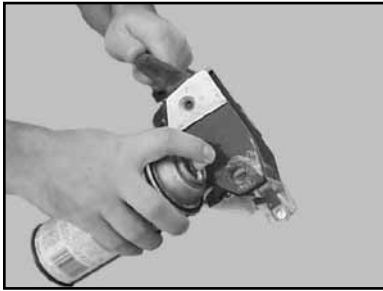

(J)  
Lubricate the Cutting Head  
Pivot Holes

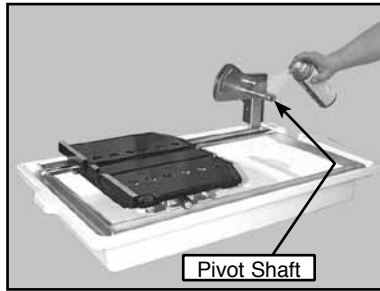

(K)  
Lubricate the Cutting Head  
Pivot Shaft



(L)  
Lubricate the Cutting Head  
Adjustment Knob

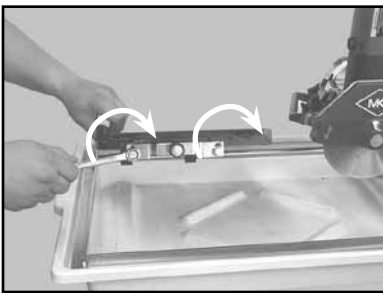

(M)  
Verify the Cutting Table Roller  
Wheel Assembly is tight

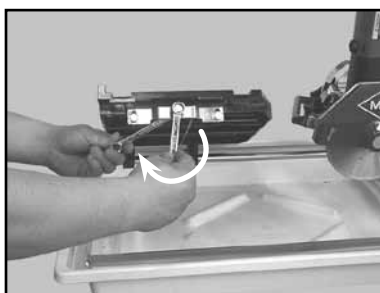

(N)  
Verify that the Roller Wheel  
is tight

### FLOW ADJUSTMENT

**NOTE:** If flow to the diamond blade requires adjustment, perform the following actions.

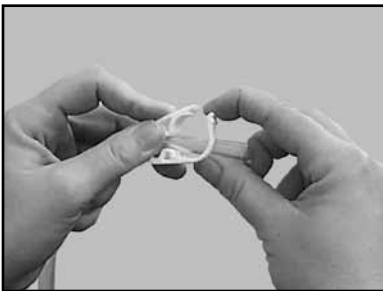

(A)  
Increase cooling flow  
by releasing the Flow  
Adjusting Clamp

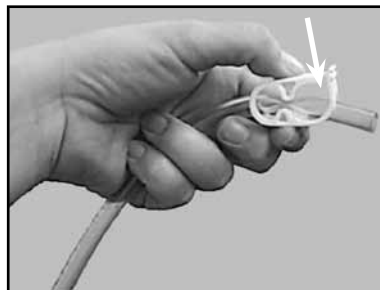

(B)  
Reduce cooling flow by  
pressing down on the Flow  
Adjusting Clamp

**BLADE DRESSING**

Like most cutting instruments, a diamond blade performs best when it is dressed. Over time and use, diamonds on the outer edge of the blade will become smoothed or “glazed” over.

This will reduce grinding efficiency and may cause the blade to “wander” or bend giving the illusion of an alignment problem. When this occurs, the blade will need to be dressed.

The diamond blade can be dressed using the MK Dressing Stick (part# 152792) and by following the steps below.

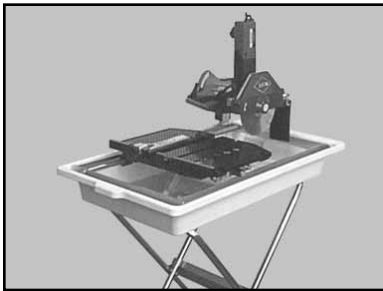

(A)  
Setup the MK-370EXP Saw for operation (See Setup, Adjustment and Operation)

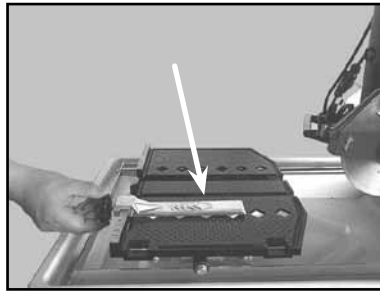

(B)  
Set the Adjustable Cutting Guide to cut a 1/16-strip

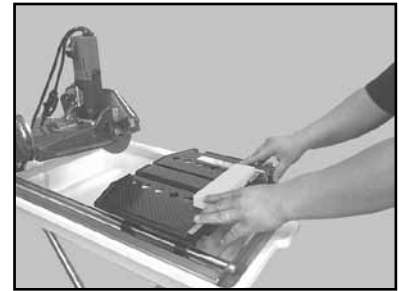

(C)  
Position the Dressing Stick

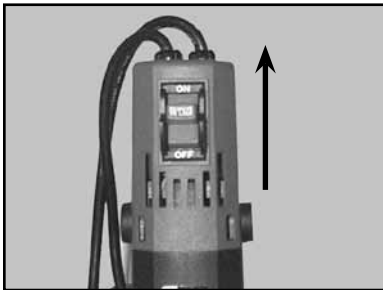

(D)  
Turn the motor ON

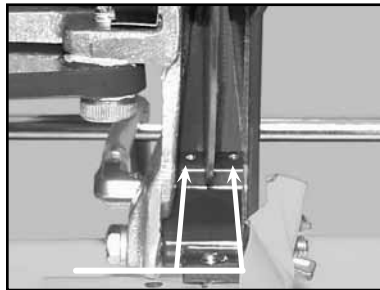

(E)  
Verify cooling flow on both sides of the blade

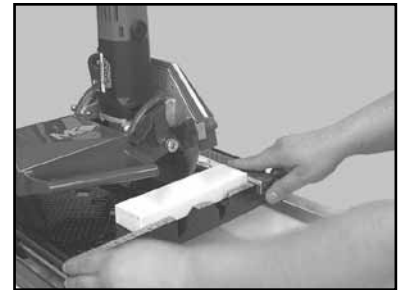

(F)  
Cut the Dressing Stick 7 or 8 times to dress the Blade



(G)  
Ensure the ON/OFF Switch is in the OFF position

**DIAMOND BLADE CHANGE-OUT**

**NOTE:** When installing the Retaining Nut, do not “cross-thread” and DO NOT over tighten the screw.

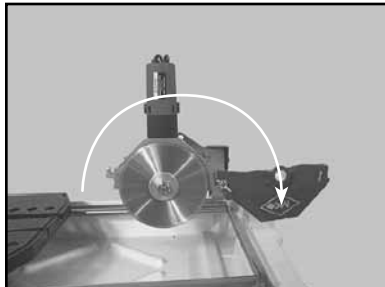

(A)  
Open the Outer Blade

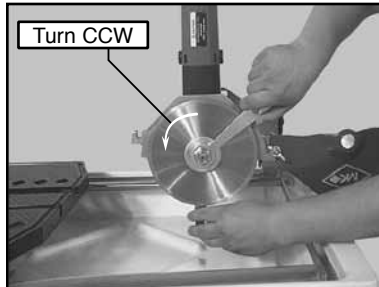

(B)  
Remove Retaining Nut and  
Outer Flange

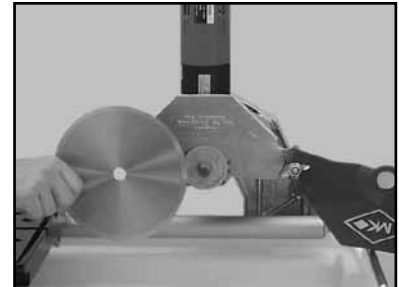

(C)  
Remove Diamond Blade  
from Blade Shaft

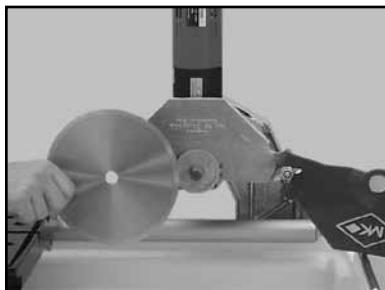

(D)  
Install the Diamond Blade  
onto Blade Shaft

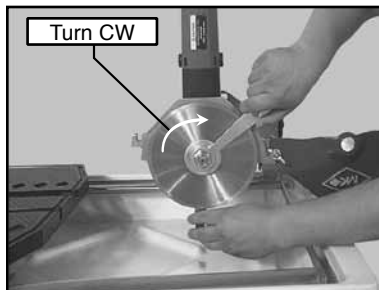

(E)  
Install the Retaining Nut  
and Outer Flange and then  
tighten using the Blade and  
Shaft Wrenches

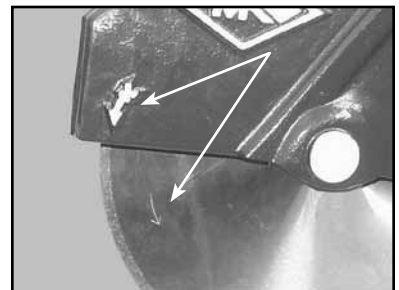

(F)  
Verify the Blade is seated on  
the Blade Shaft and direction  
of rotation is correct

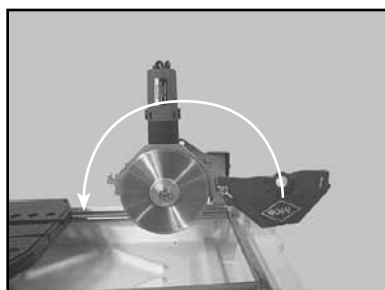

(G)  
Close the Outer Blade

**ALIGNMENT**

The Movable Cutting Table of the MK-370EXP Saw is pre-aligned in the factory. It may become misaligned with the Cutting Head of the Tile Saw over time. Should misalignment occur, perform the following steps to realign it.

**NOTE:** If alignment problems are the result of a warped blade, a bent frame or bent support arm, or, if alignment is off by more than 1/8-inch, contact the MK Diamond Service Center - (800) 474-5594

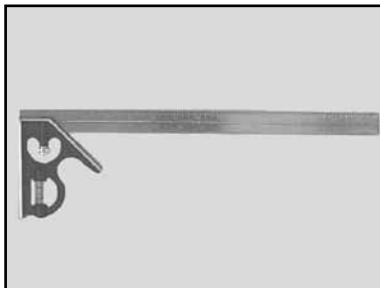
**TOOLS NEEDED**

Combination Square  
12-inch or Greater



1/2-inch Wrench



1/4-inch Wrench

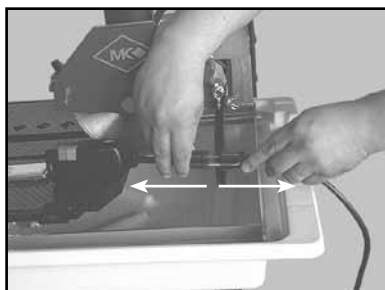

Flat Head Screwdriver

**PREPARATION**

(A)  
Remove Tile Saw  
from Power Source



(B)  
Inspect Tile Saw  
for damage

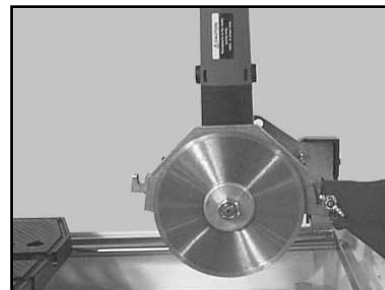

(C)  
Inspect Diamond Blade  
for damage

**MOVABLE CUTTING TABLE ALIGNMENT VERIFICATION**

This will verify the Movable Cutting Table is aligned to the frame of the saw.

**NOTE:** If the blade is misaligned following alignment verification, attempt to align using Alignment Screw, 90° Verification. The Diamond Blade must be removed and reinstalled when removing the Blade Guard.

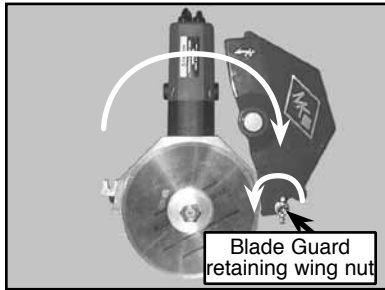

(A)  
Remove Blade Guard

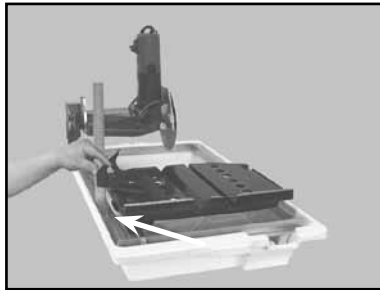

(B)  
Place Square on guide bar side of cutting table

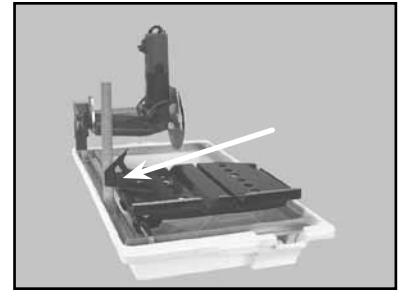

(C)  
Lock in position

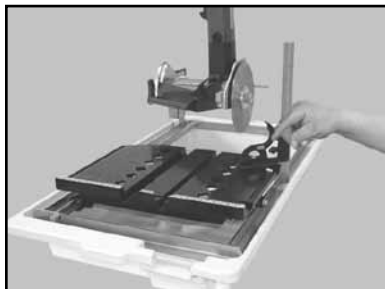

(D)  
Move Square to wheel assembly side of the cutting table

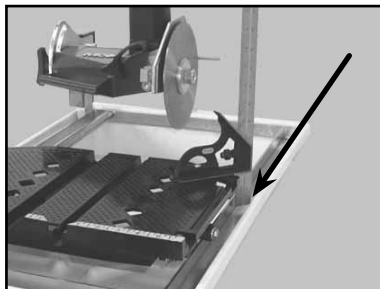

(E)  
Verify Wheel Assembly side of Movable Cutting Table height is same as Guide Bar side

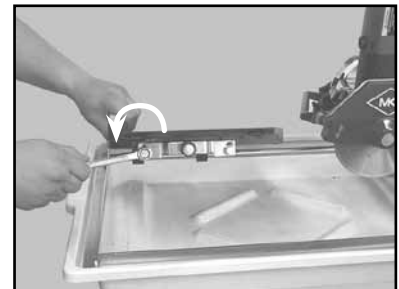

(F)  
If gap exists, loosen Movable Cutting Table Wheel Assembly

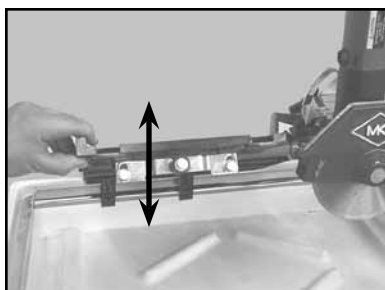

(G)  
Move Wheel Assembly up or down to Square the Movable Cutting Table

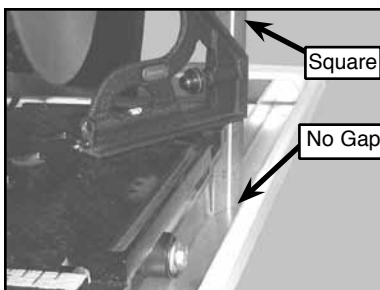

(H)  
Check that there is no gap between the Square and the wheel assembly side of frame



(I)  
Tighten Movable Cutting Table Wheel Assembly



**ALIGNMENT SCREW, 90° VERIFICATION**

90°- alignment verification will ensure that the blade will cut the tile straight up and down and not at an angle.

**NOTES:** If the blade is misaligned following this alignment procedure, return the saw to MK Diamond for repair. The Diamond Blade must be removed and reinstalled when removing the Blade Guard.

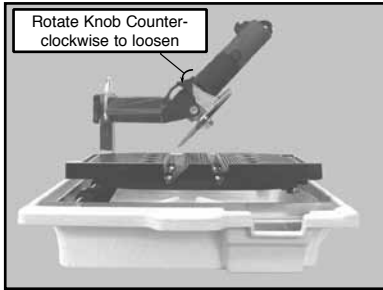

(A)  
Position the Cutting Head to the 45° Cutting Angle

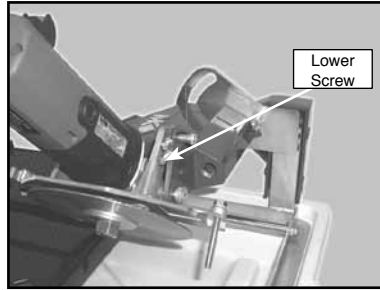

(B)  
Locate the 90° Adjustment Screw

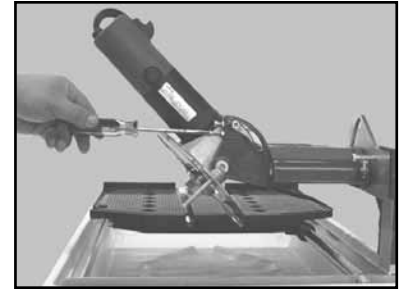

(C)  
Rotate 90° Adjustment Screw clockwise or counter-clockwise to realign Cutting Head

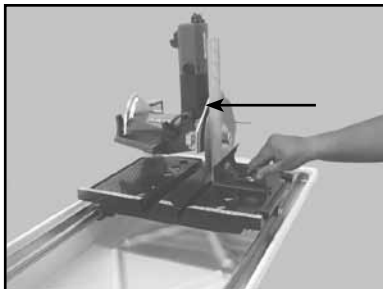

(D)  
Position the Square on Movable Cutting Table against the Diamond Blade

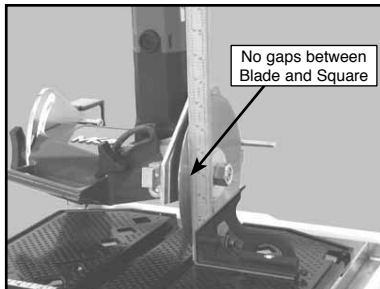

(E)  
Verify the Diamond Blade is Square to the Movable Cutting Table



(F)  
Repeat Steps A to E as necessary to align the Cutting Head

**HORIZONTAL ROUGH ALIGNMENT**

The Horizontal alignment will ensure that straight cuts (or Rip Cuts) are made.

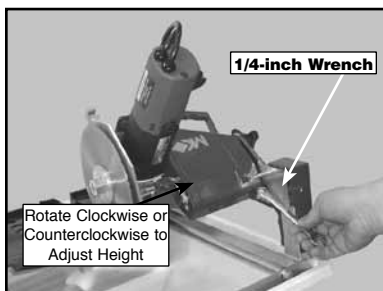

(A)  
Position Cutting Head to normal Cut Depth

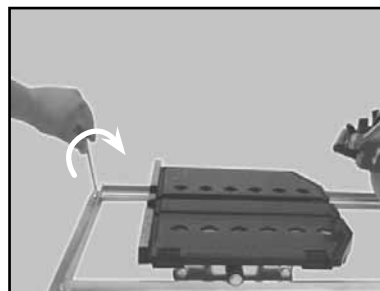

(B)  
Loosen front and rear Guide Bar Retaining Bolts

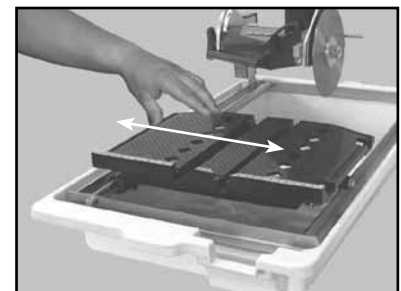

(C)  
Move Guide Rail and Table until the Blade is centered in Cutting Groove

**HORIZONTAL FINAL ALIGNMENT**

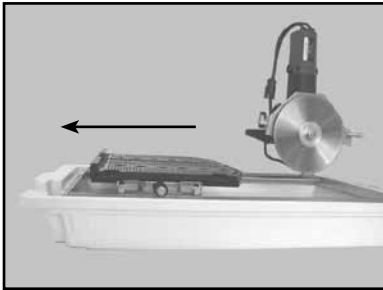

(A)  
Pull Movable Cutting Table  
to front of Tile Saw

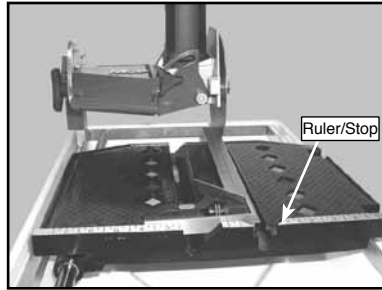

(B)  
Position Square flat on Movable  
Cutting Table against Ruler/Stop

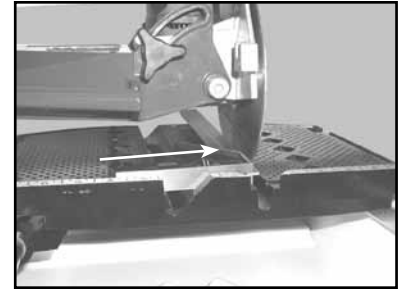

(C)  
Position front of Square  
against Blade



(D)  
Move Guide Bar and table  
until Square rests evenly  
across Blade

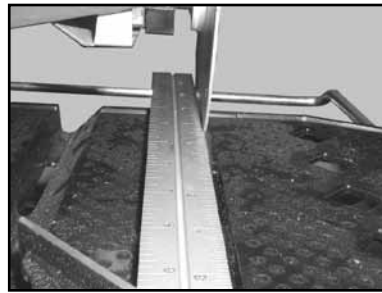

(E)  
Position end of Square  
against Blade



(F)  
Move Guide Bar and table  
until Square rests evenly  
across Blade

**HORIZONTAL ALIGNMENT VERIFICATION**

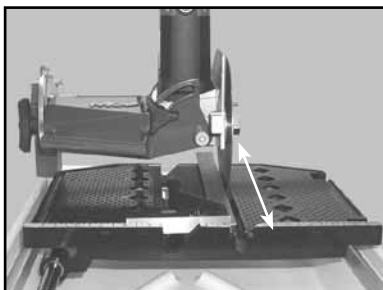

(A)  
Move the Cutting Table  
back and forth to verify  
Blade is even  
across all points of Square

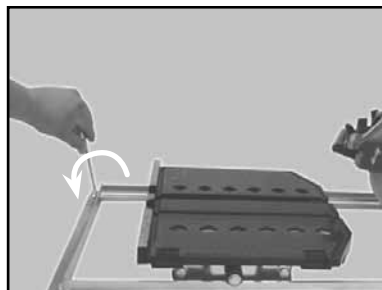

(B)  
Tighten Guide Bar  
Retaining Bolts

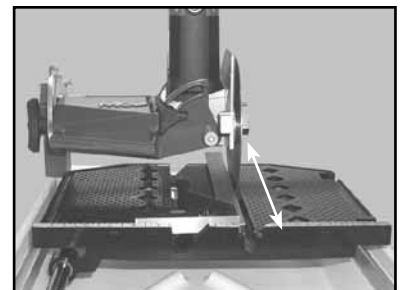

(C)  
Move the Cutting Table  
back and forth to re-verify  
Blade is even across all  
points of Square

**45° ALIGNMENT VERIFICATION**

The 45° Alignment Verification is done to ensure the blade will cut tile at a 45° angle.

**NOTE:** If the blade is misaligned following this alignment procedure, return the saw to MK Diamond for repair. The Diamond Blade must be removed and reinstalled when removing the Blade Guard.

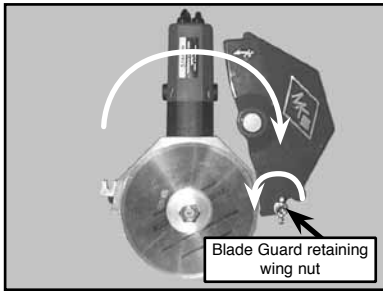

(A)  
Remove Blade Guard  
(If not done Previously)

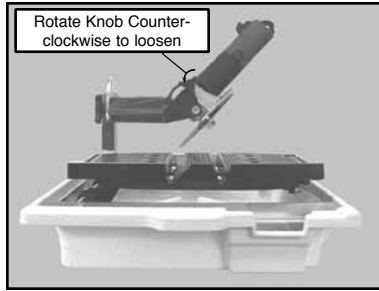

(B)  
Position the Cutting Head  
to the 45° Cutting Angle

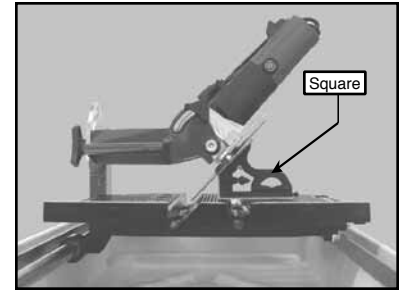

(C)  
Place Square on the Movable  
Cutting Table and position the  
Square against the Blade

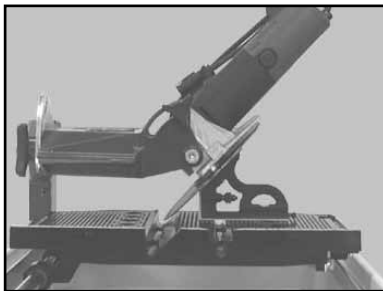

(D)  
Verify Blade is even  
across all points of Square  
and there are no gaps  
between Blade and Square

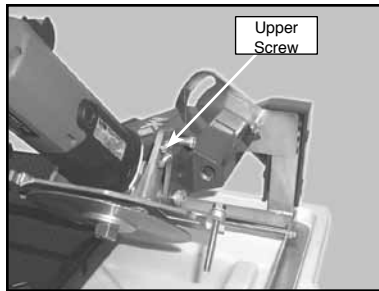

(E)  
To Adjust 45° Cutting  
Angle, locate the  
45° Adjustment Screw

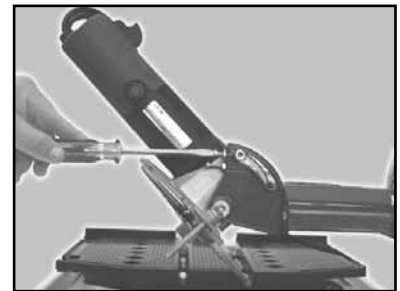

(F)  
Rotate 45° Adjustment Screw  
clockwise or counter-  
clockwise to realign 45°  
Cutting Angle

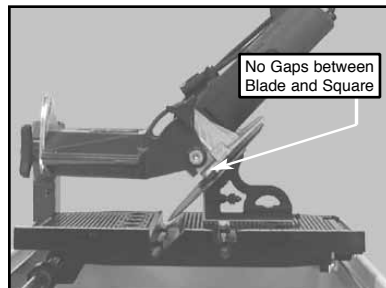

(G)  
Verify Blade is now even  
across all points of Square

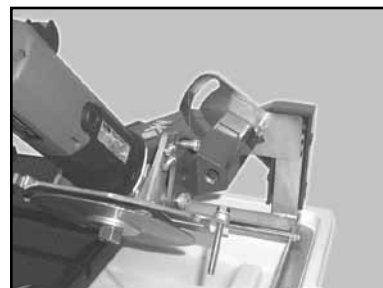

(H)  
Repeat steps A to G until Blade is  
even across all points of Square

**BLADE WILL NOT CUT PROPERLY**



(A)  
Check for Smoothness or "Glazing" (Dress blade if needed)

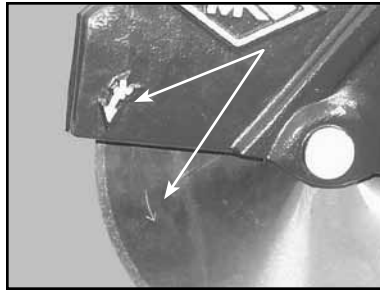

(B)  
Check for proper rotation



(C)  
Ensure the Blade Core is not bent and Arbor is not out of round



(D)  
Verify the blade is correct for the material being used

**MOVABLE CUTTING TABLE DOES NOT MOVE CORRECTLY**



(A)  
Check that the Guide Bar is clean – clean if dirty

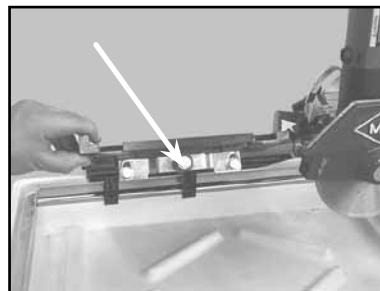

(B)  
Check the Movable Cutting Table Roller Wheel for wear replace if necessary

COOLING FLOW

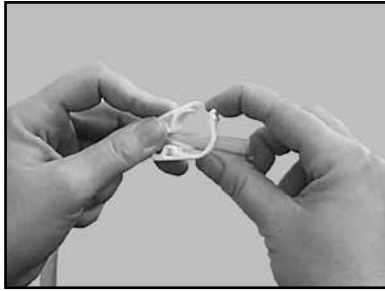

(A)  
Check cooling flow  
Adjusting Clamp open

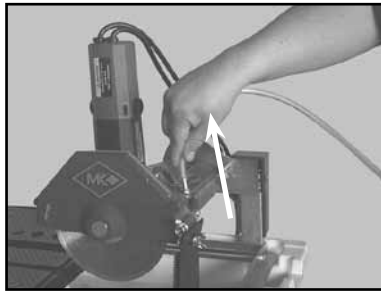

(B)  
Remove the Cooling  
Transfer Tube from the  
Blade Guard inlet

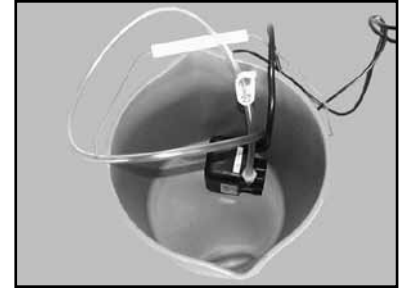

(C)  
Place Pump into a bucket  
of water and check flow



(D)  
Remove the Cooling  
Transfer Tube and check  
flow



(E)  
Remove the Pump  
Discharge Fitting and  
check

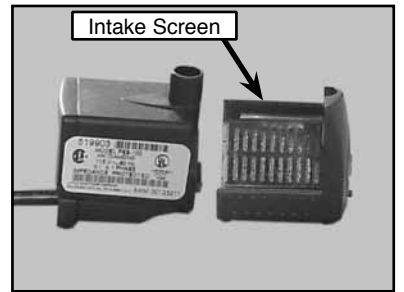

(F)  
Remove the Pump Intake  
Screen and check for  
debris

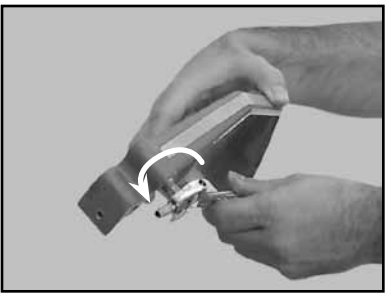

(G)  
Remove the Blade Guard  
Intake Fitting

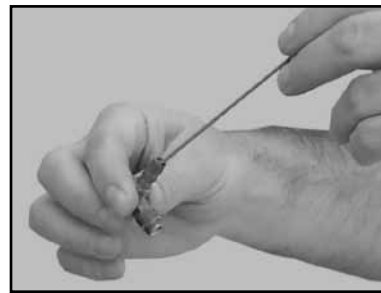

(H)  
Clean the Blade Guard  
Intake Fitting

**NOTE:** “Rodding” cooling channels is performed by inserting a small wire rod through the cooling inlet on top of the Blade Guard and directing the rod out through each of the cooling flow tubes located on the underside of the Blade Guard. The cooling channels should be “rodded” until all ports are free of foreign debris.

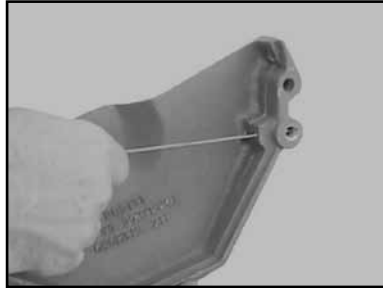

(K)  
Rod Cooling Channels  
and recheck flow

## BLADE STOPS TURNING

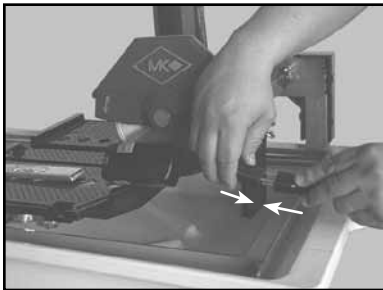

(A)  
Verify all plugs are fully  
installed

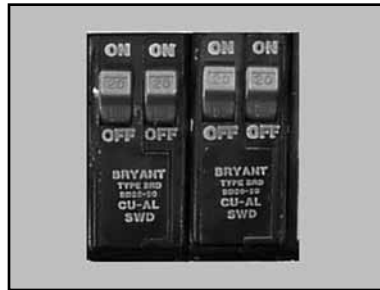

(B)  
Check to see if the wall outlet  
Ground Fault Circuit Interrupter  
(GFCI) is tripped. Verify circuit  
breaker not tripped. If tripped,  
reset once

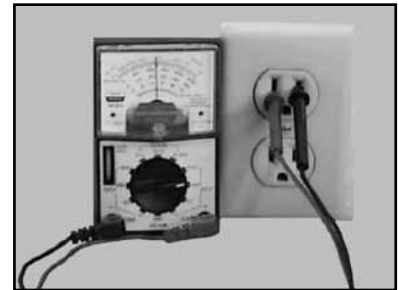

(C)  
Check power source voltage  
is 120v – if not 120v, move to  
another circuit



TILE SAW ASSEMBLY  
PART# 159943

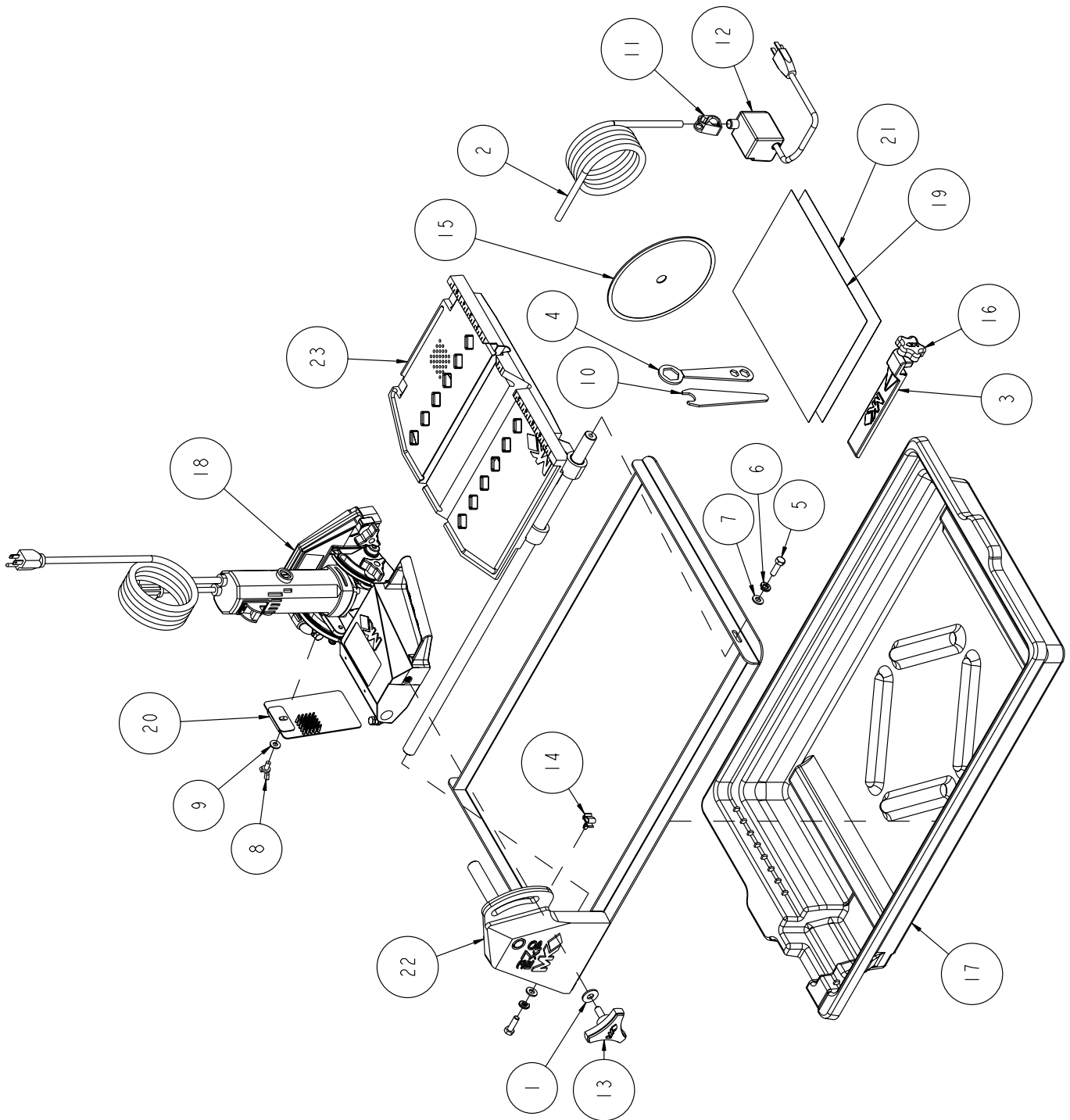



ITEM NO.	DESCRIPTION	QTY. REQ.	PART OR IDENTIFYING NO.
1	WASHER, FLAT CUT 3/8	1	101360
2	HOSE, WATER VINYL 1/2 X 3/8 TSAW (6.0')	1	132951
3	CASTING, ACC RIP GUIDE - COMP	1	134551
4	WRENCH, TILES AW, 15/16 - 18 X 1	2	134684
5	SCREW, HEX HD, 5/16 - 18 X 1	2	151743
6	WASHER, LOCK, SPLIT, 5/16	2	151747
7	WASHER, FLAT, SAE, 5/16	2	151754
8	SCREW, WING, 1/4 - 20 X 1/2	1	151888
9	WASHER, 1/4 SAE FLAT	1	151915
10	WRENCH, TILES AW, 11/16 OPEN END	1	153450
11	CLAMP, HOSE 1/2 - 3/4	1	154394
12	PUMP, WATER, 115V 60HZ	1	155981-VP
13	KNOB, TRI PLASTIC, 1"	1	156770-01
14	CLIP, CORD 1/4" PUSH MOUNT	1	157259
15	MK-HDTCM WET 7 X 060 X 7/8 CONT	1	157913
16	KNOB, RUBBER, 1/4 -20 X 3/4" LONG	1	159428-1
17	PAN, WATER MK-370EXP/1080	1	160041
18	ASSY, CUTTING HEAD, 120V	1	160042
19	OWNERS MANUAL MK-370EXP	1	160084
20	GUARD, SPLASH	1	160310
21	SHEET, WARNING LABELS, TILE SAW	1	166012
22	ASSY, FRAME, 370EXP	1	167450
23	ASSY, TABLE, 370EXP	1	168025

**CUTTING HEAD ASSEMBLY  
PART# 160042**

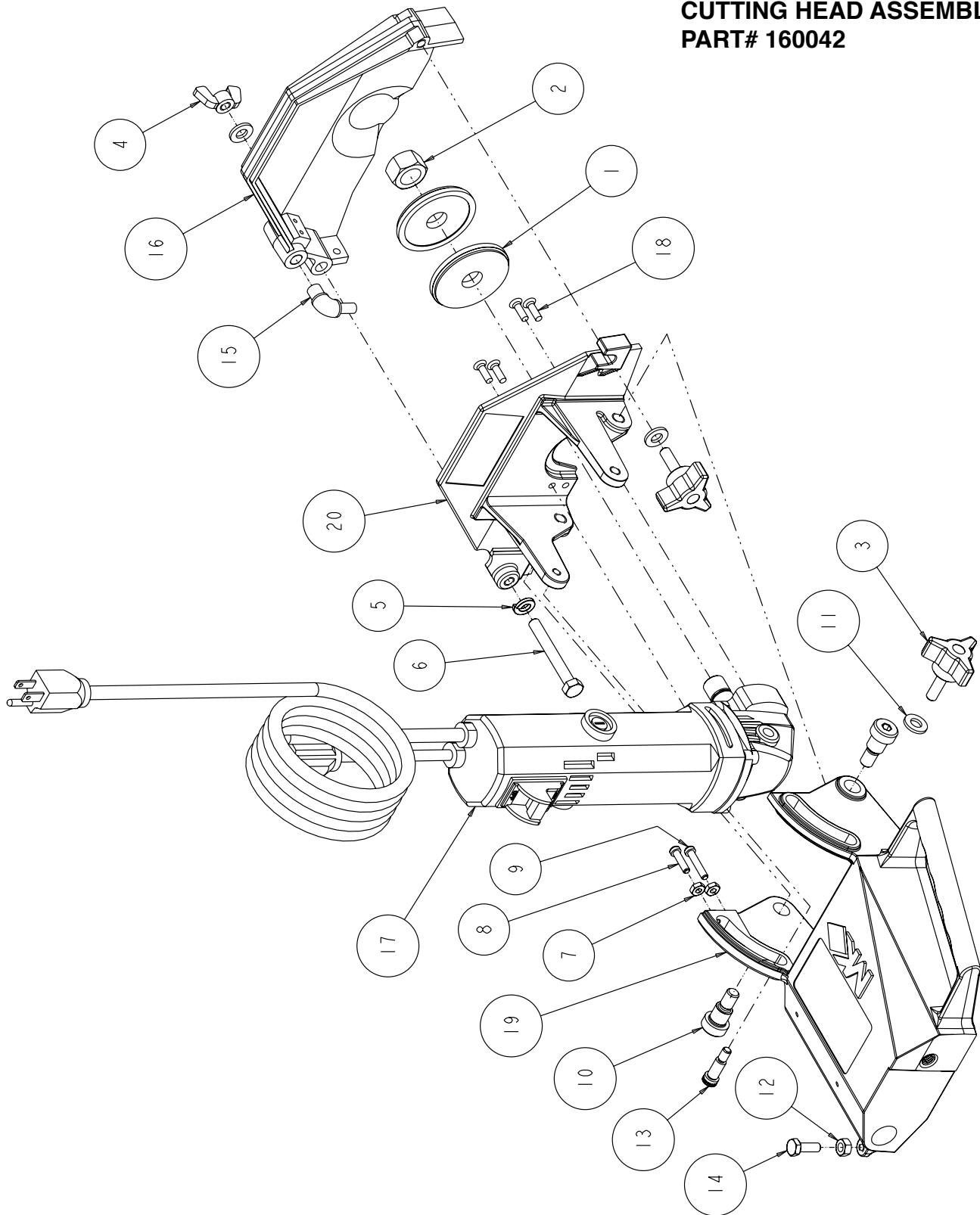

ITEM NO.	DESCRIPTION	QTY. REQ.	PART OR IDENTIFYING NO.
1	FLANGE, OUTER, 2-3/8	2	135830
2	NUT,HEX, 5/8 - 18	1	135848
3	KNOB, DAVIES, 5/16 - 18 X 1	2	151681
4	NUT, WING, NYLK, 5/16 - 18	1	151746
5	WASHER, LOCK, SPLIT, 5/16	1	151747
6	BOLT, HEX HD TAP, 5/16 - 18 X 2 - 1/2	1	151748
7	NUT, HEX, 10-24	2	151749
8	SCREW, FIL HD, SLT, #10 - 24 X 3/4	1	151750
9	SCREW, FIL HD, SLT, #10 - 24 X 1	1	151751
10	SCREW, SHOULDER, 1/2 X 1/2	2	151753
11	WASHER, FLAT, SAE, 5/16	3	151754
12	NUT, HEX, 1/4 - 20	1	1515893
13	SCREW SHOULDER 5/16 X 5/8	1	152137
14	SCREW HEX HD, 1/4 - 20 X 3/4	1	152370
15	ELBOW, 1/8 MNPT X 1/4 BARB 90DEG	1	154652
16	CASTING, BLD GRD, 7 INCH BLADE (COMP)	1	154811
17	MTR, ELECT, 7.4 AMP 120V	1	156428-R
18	SCREW, FLAT HD 10 -32 X 5/8"	4	157554
19	CASTING, COMMON PART, CTTG HD-C	1	159937
20	CASTING, MTR MOUNT, COMMON-COMP	1	159941

**TABLE ASSEMBLY**  
**PART# 168025**

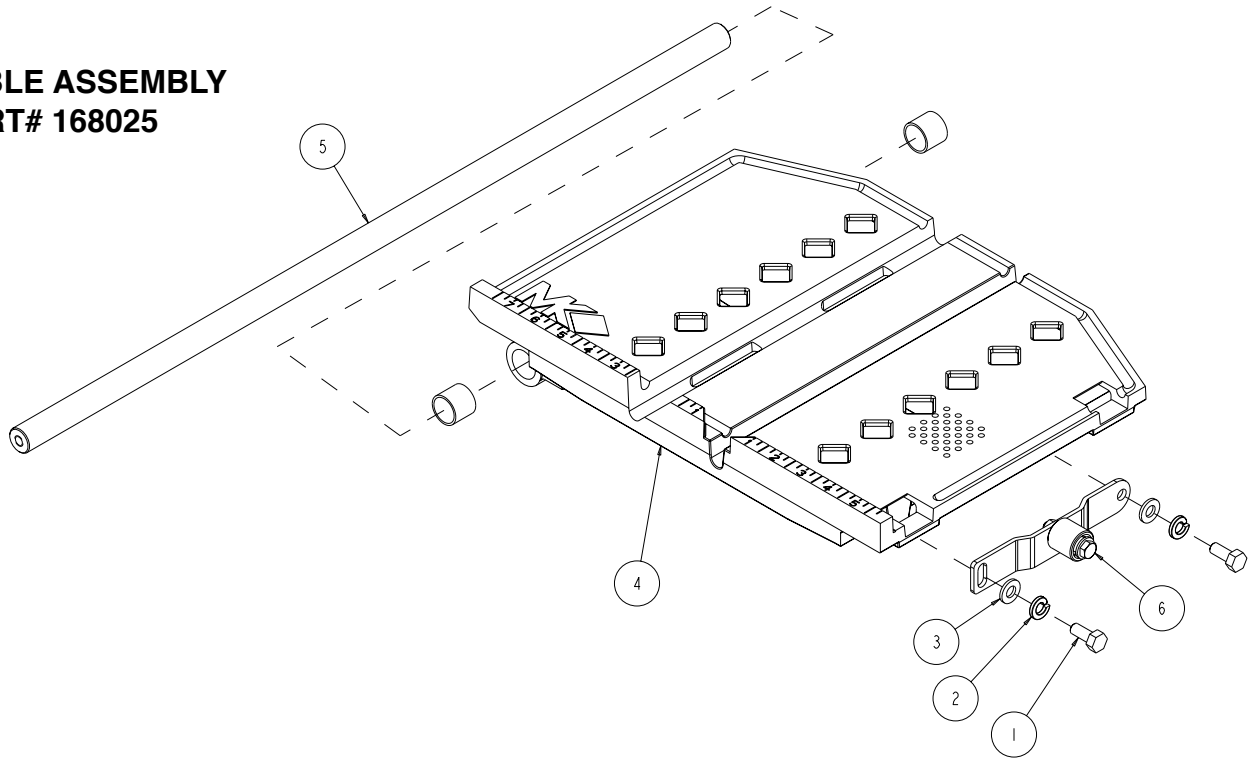

**FRAME ASSEMBLY**  
**PART# 167450**

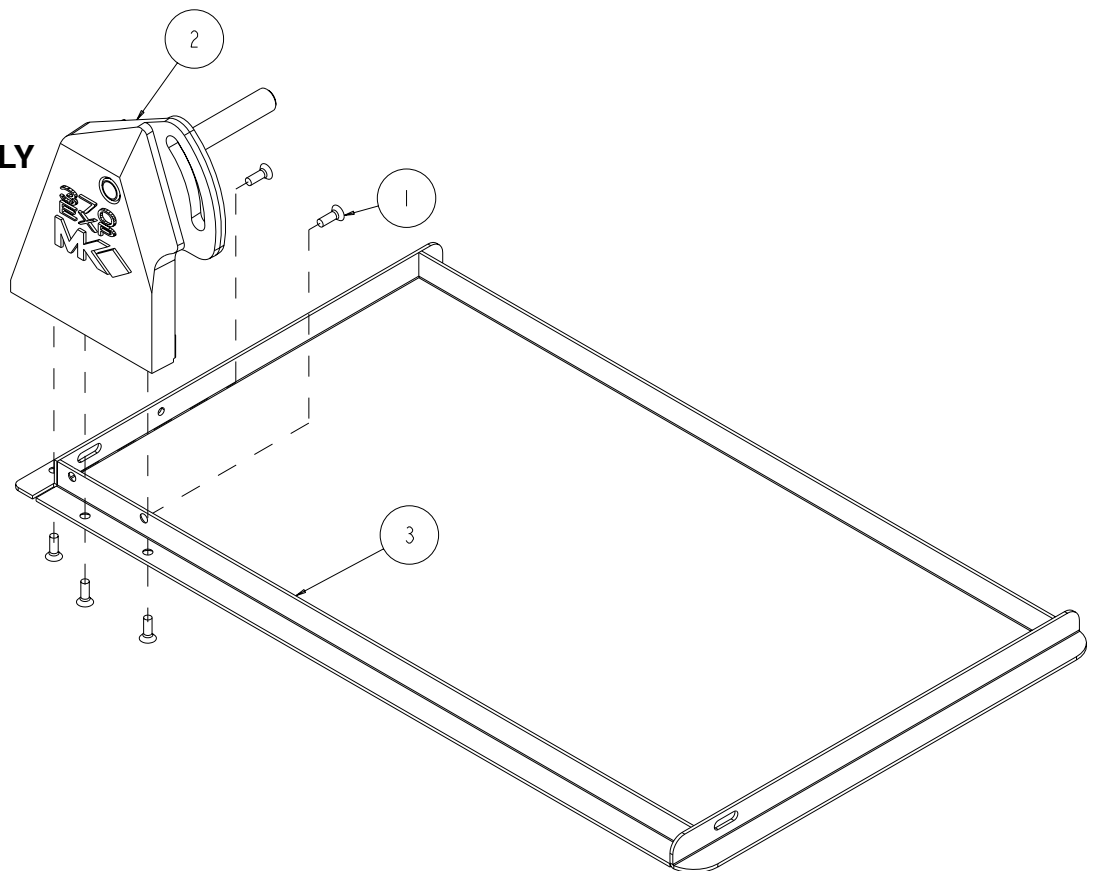

**TABLE ASSEMBLY**

ITEM NO.	DESCRIPTION	QTY. REQ.	PART OR IDENTIFYING NO.
1	SCREW, 5/16 - 18 X 1 HEX HEAD MACHINE	2	151369
2	WASHER, LOCK, SPLIT, 5/16	2	151747
3	WASHER, 5/16 SAE FLAT	2	151754
4	CASTING, TABLE, 370/770EXP - COMP	1	159939
5	BAR, GUIDE 3/4 DIA	1	159942
6	ASSEMBLY, ROLLER WHEEL	1	168023

**FRAME ASSEMBLY**

ITEM NO.	DESCRIPTION	QTY. REQ.	PART OR IDENTIFYING NO.
1	SCREW, 1/4 -20 X /34 FLAT HEAD PHILLIPS MACHINE	5	154657
2	CASTING, POST MOUNT, COMP	1	167448
3	WELDMENT, FRAME	1	167449

ITEM	NUMBER	DESCRIPTION	
1.	158434	MK-225, 7 x 5/8 Arbor	
2.	139311	MK-215, 7 x 5/8 Arbor	
3.	153293	MK-315, 7 x 5/8 Arbor	
5.	134577- MK	Dual 45° Flat Angle Guide	
6.	134569- MK	90° Protractor	
8.	152792	Dressing Stone	
10.	160488	Side Table	

**ORDERING INFORMATION**

---

You may order MK Diamond products through your local MK Diamond distributor or, you may order direct from MK Diamond.

NOTE: There is a \$25.00 minimum order when ordering direct from MK Diamond. All purchases must be made using VISA, MasterCard or American Express.

When ordering direct from MK Diamond, please have the following information ready before calling:

- The Model Number of the saw
- The Serial Number of the saw
- Where the saw was purchased and when
- The Part Number for the part(s) being ordered
- The Part Description for the part(s) being ordered

All parts may be ordered by calling toll free to – 800 421-5830 or 310 539-5221 and asking for Customer Service. For technical questions, call – 800 474-5594.

**RETURN MATERIALS POLICY**

---

To expedite the service relative to the return of a product purchased through MK Diamond, please observe the following:

NOTE: When returning all items, they must have been purchased within the previous twelve (12) months.

- Have the Model Number of the saw
- Have the Serial Number of the saw
- Have the location of where the saw was purchased
- Have the date when the saw was purchased
- Contact Customer Service for approval to return the item(s)
- Obtain a Returned Goods Number (RGA) authorizing the return
- Follow the packaging instructions in the following section
- Ensure your item(s) are prepaid to the destination

For returned items, call toll free to – 800 421-5830 or 310 539-5221 and ask for Customer Service. For technical questions, call – 800 474-5594 or 310 257-2845.

**PACKAGING INSTRUCTIONS**

---

- Remove the Blade guard and Support Angle Assembly
- Dry the saw before shipping
- When packing, include the following: MK-370EXP Saw, Diamond Blade, Blade guard and Support Angle Assembly and Adjustable Cutting Guide (Other Accessories are not required)
- Package the unit in its original container or one of comparable size (do not ship the unit partially exposed)
- Ensure all parts are secured in the packaging to prevent moving

**AUTHORIZED SERVICE CENTERS**

---

For quicker repair time, you may contact MK Diamond Customer Service, toll free, at 800 421-5830 or 310 539-5221 for the Authorized Service Center closest to you or visit our web site at [www.mkdiamond.com](http://www.mkdiamond.com). For technical questions, call – 800 474-5594.

**MK-370EXP TILE SAW**  
OWNERS MANUAL, PARTS LIST  
& OPERATING INSTRUCTIONS



**MK Diamond Products, Inc.**

MK Diamond Products, Inc.  
1315 Storm Parkway  
Torrance, CA 90501

Toll-Free: (800) 421-5830  
Phone: (310) 539-5221  
Fax: (310) 539-5158  
[www.mkdiamond.com](http://www.mkdiamond.com)