

**MK-2000 ELECTRIC SERIES
MASONRY SAW
OWNER'S MANUAL,
OPERATING INSTRUCTION, &
PARTS LIST**



Revision 202	01.2016
Manual Part No. 156402	

MK-2002 PART # 150598
MK-2001SV PART # 161195

Caution: Read all safety and operating instructions before using this equipment. This owners manual **MUST** accompany the equipment at all times.

INTRODUCTION

We at MK Diamond want to congratulate you on selecting the saw. We are certain that you will be pleased with your purchase. MK Diamond takes pride in producing the finest products in the industry.

Operated correctly, your saw should provide you with years of quality service. In order to help you, we have included this manual. This owners manual contains information necessary to operate and maintain your saw safely and correctly. Please take a few minutes to familiarize yourself with the saw by reading and reviewing this manual.

Read and follow all safety, operating and maintenance instructions.

If you should have questions concerning your saw, please feel free to call our friendly customer service department at: 800 421-5830

Regards,

MK Diamond

NOTE THIS INFORMATION FOR FUTURE USE:

MODEL NUMBER:	
SERIAL NUMBER:	
PURCHASE PLACE:	
PURCHASE DATE:	

NOTE: For your (1) one year warranty to be effective, complete the warranty card (including the Serial Number) and mail it in as soon as possible.

TABLE OF CONTENT

	Page
SAFETY	
Safety Message/Alert Symbols, Warnings	4
Hazard Symbols	5
General, Maintenance, Saw Safety	6-7
California Proposition 65 Message	8
Electrical Requirements and Grounding Instructions	9-11
Lockout	12
Safety Label Locations	13
Product Specifications	14
PRODUCT SPECIFICATIONS	
Unpacking	15
Contents	15
Transport	15
SETUP, ADJUSTMENT AND OPERATION	
Setup / Assembly	16-17
Water Pump Preparation	17
Diamond Blade Installation	18
Pre-start Inspection	19
Water Pump Connection	20
Operation	20-21
Step Cuts	22
Chop Cuts	23-24
Angle Cuts	25
MAINTENANCE	
Cleanup	26
Maintenance	27-31
EXPLODED VIEW AND PARTS LIST	
Exploded View & Parts List	32-44
ACCESSORIES	
Accessories	45
ORDERING AND RETURNING INSTRUCTIONS	
Ordering Information, Return Material Policy, & Packaging	46
CONTACT & LIMITED WARRANTY	
Contact & Warranty	47

Read and follow all safety, operating and maintenance instructions. Failure to read and follow these instructions could result in injury or death to you or others. Failure to read and follow these instructions could also result in damage and/or reduced equipment life. Safety warnings and guidelines do not by themselves eliminate danger. They are not substitutes for proper accident prevention procedures and good judgement.

SAFETY MESSAGES

A safety message alerts you to potential hazards that could hurt you or others. Each safety message is preceded by a safety alert symbol () and one of three words: **DANGER**, **WARNING**, or **CAUTION**.



DANGER You **WILL** be **KILLED** or **SERIOUSLY INJURED** if you **DO NOT** follow directions.



WARNING You **CAN** be **KILLED** or **SERIOUSLY INJURED** if you **DO NOT** follow directions.



CAUTION You **CAN** be **INJURED** if you **DO NOT** follow directions. It may also be used to alert against unsafe practices.

DAMAGE PREVENTION AND INFORMATION MESSAGES

A Damage Prevention Message is to inform the user of important information and/or instructions that could lead to equipment or other property damage if not followed. Information Messages convey information that pertains to the equipment being used. Each message will be preceded by the word **NOTE**, as in the example below.

NOTE: Equipment and/or property damage may result if these instructions are not followed.

GENERAL SAFETY PRECAUTIONS AND HAZARD SYMBOLS

In order to prevent injury, the following safety precautions and symbols should be followed at all times!

SAFETY PRECAUTIONS



ALWAYS read this Owner's Manual before operating the machine. **DO NOT** operate or service this equipment before reading this entire manual. Read and understand all warnings, instructions and controls on the machine. Know how to stop the equipment quickly in case of emergency. It is the operators responsibility to use this machine under safe working conditions and conform with federal, state and local codes or regulations pertaining to safety, air, pollution, noise etc...

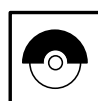

ALWAYS keep the Blade and Belt Guards in place. **DO NOT** operate this machine with any guard or safety device removed. A Guard, or any damaged part should be repaired or replaced immediately.

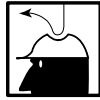

NEVER operate this equipment without proper protective clothing, shatterproof glasses, steel-toed boots and other protective devices required by the job. Non-slip foot wear is recommended.

**PERSONAL PROTECTIVE EQUIPMENT**

ALWAYS wear approved respiratory, head, ear and eye protection when operating this machine.

ACCIDENTAL STARTS!

Before starting the engine/motor, be sure the **ON/OFF** switch is in the **OFF** position to prevent accidental starting. Place the **ON/OFF** switch in the **OFF** position before performing any service operation. **ALWAYS** place the power **ON/OFF** switch in the **OFF** position when the machine is not in use.

**ROTATING PARTS**

Keep hands, feet, hair, and clothing away from all moving parts to prevent injury. Never operate the motor with covers, shrouds, or guards, removed.

**HOT PARTS!**

Engine components can become extremely hot from operation. To prevent severe burns, do not touch these areas while the engine is running, or immediately after it is turned off. Never operate the engine with heat shields removed.

**OVER SPEED**

NEVER tamper with the governor components or settings to increase the maximum speed. Severe personal injury and damage to the engine or equipment can result if operated at speeds above maximum.

**ELECTRICAL SHOCK**

NEVER touch electrical wires or components while the engine is running. Exposed, frayed or worn electrical wiring and plugs can be sources of electrical shock which could cause severe injury or burns. Do not touch the plug with wet hands.



ALWAYS avoid inhalation of and skin contact with silica dust and/or mist. Provide proper dust removal. Use dust-collection system when applicable.



NEVER operate the machine in an explosive atmosphere or near combustible materials. Sparks from the cutting-action of this machine can ignite flammable materials, liquids, gases or dust.



This equipment should not be operated by persons under 18 years of age.

**KEEP CHILDREN AWAY**

All visitors and children should be kept a safe distance from work area. Maintain a safe operating distance to other personnel.

**MAKE THE WORKSHOP KID PROOF**

Make the workshops kid proof by using padlocks, master switches or by removing starter keys.

**DO NOT FORCE THE TOOL**

A power tool will do a job better and safer operating at the rate for which it was designed. **DO NOT** force a tool or an attachment to do a job that it was not designed to do.

**USE PROPER APPAREL**

DO NOT wear loose clothing, gloves, neckties, rings, bracelets, or other jewelry that may be caught in moving parts. Non-slip footwear is recommended. Wear protective hair covering to contain long hair.

**SECURE WORK**

Clamps or a vise should be used to hold work whenever practical. Keeping your hands free to operate a power tool is safer.

**DO NOT OVERREACH**

Keep proper footing and balance at all times by not overreaching.

**DISCONNECT TOOLS**

Power tools should always be disconnected before servicing, adjusting or when changing accessories, such as blades, bits, cutters, and the like.

**MAINTAIN TOOLS WITH CARE**

Keep tools clean and maintained for the best and safest performance. Always follow maintenance instructions and examine the machine before use. If any abnormal vibrations or noises occurs, turn off machine immediately and have the problem corrected before further use.

**REMOVE ADJUSTING KEYS AND WRENCHES**

Form a habit of checking to see that keys and adjusting wrenches are removed from the power tool before it is turned on.

**KEEP WORK AREA CLEAN**

Cluttered work areas and benches invite accidents. Keep area around machine clear of obstructions which could cause persons to fall.

**DO NOT USE IN DANGEROUS PLACES**

DO NOT operate equipment in dangerous or hazardous environments. **DO NOT** use power tools in damp or wet locations nor expose them to rain. Always keep the work area well lighted.

**USE RECOMMENDED ACCESSORIES**

Consult the owner's manual for recommended accessories. Using improper accessories may increase the risk of personal or by-stander injury. Unauthorized equipment modifications will void all warranties. Manufacturer does not assume responsibility for any accident due to equipment modifications.



ALWAYS ensure that the machine is on level ground before using.

**NEVER STAND ON THE TOOL**

Serious injury could occur if a power tool is tipped, or if a cutting tool is unintentionally contacted.

**TRANSPORT**

When loading or unloading the machine, use caution. Remove the blade prior to hoisting, loading and transporting the machine.

**CHECK FOR DAMAGED PARTS**

Before using a power tool, check for damaged parts. A guard or any other part that is damaged should be carefully checked to determine if it would operate properly and perform its intended function. Always check moving parts for proper alignment or binding. Check for broken parts and mountings and all other conditions that may affect the operation of the power tool. A guard, or any damaged part, should be properly repaired or replaced. Always check the machine for loose bolts before starting.

**DIRECTION OF ROTATION**

A blade or cutter should always be installed so that rotation is in the direction of the arrow imprinted on the side of the blade or cutter. It should correspond with the rotational direction of the motor. Always feed work into a blade against the direction of rotation.

**NEVER LEAVE A TOOL UNATTENDED**

TURN POWER OFF - Do not leave a tool until it comes to a complete stop. **ALWAYS** turn a power tool **OFF** when leaving the work area, or, when a cut is finished.



NEVER disconnect any "emergency or safety devices". These devices are intended for operator safety. Disconnection of these devices can cause severe injury, bodily harm, or even death! Disconnection of any of these devices will void all warranties. Unauthorized equipment modifications will void all warranties. Manufacturer does not assume responsibility for any accident due to equipment modifications.



NEVER use this machine with any cutter designed for woodworking.



NEVER operate this equipment when not feeling well due to fatigue, illness or taking medicine.



NEVER operate this equipment under the influence of drugs or alcohol.



On belt driven equipment, overtensioning of belts will result in premature crank and/or bearing failure.



Whenever necessary, replace nameplate, operation and safety decals when they become difficult to read.



ALWAYS store equipment properly when it is not being used. Equipment should be stored in a clean, dry location out of the reach of children



DO NOT lend or rent this equipment without including the Owner's Manual and the Engine/Motor Manufacturer's Manual.



Check the chemical properties of the material to be cut/grinded and follow all EPA/OSHA Regulations.

SILICA DUST WARNING

Grinding/cutting/drilling of masonry, concrete, metal and other materials with silica in their composition may give off dust or mists containing crystalline silica. Silica is a basic component of sand, quartz, brick clay, granite and numerous other minerals and rocks. Repeated and/or substantial inhalation of airborne crystalline silica can cause serious or fatal respiratory diseases, including silicosis. In addition, California and some other authorities have listed respirable crystalline silica as a substance known to cause cancer. When cutting such materials, always follow respiratory precautions.

Use appropriate NIOSH-approved respiratory protection where dust hazard may occur. Paper masks or surgical masks without a NIOSH approval number are not recommended because they do little to protect the worker. For more information about respirator programs, including what respirators have received NIOSH approval as safe and effective, please visit the NIOSH website at:
<http://www.cdc.gov/niosh/topics/respirators>

Observe OSHA regulations for respirator use (29 C.F.R. §1910.134).
Visit <http://www.osha.gov> for more information.

CALIFORNIA PROPOSITION 65 MESSAGE

Some dust created by power sanding, sawing, grinding, drilling, and other construction activities contain chemicals known (to the State of California) to cause cancer, birth defects or other reproductive harm. Some examples of these chemicals are:

- Lead, from lead-based paints
- Crystalline silica from bricks, cement and other masonry products
- Arsenic and chromium, from chemically treated lumber

For further information, consult the following sources:
<http://www.osha.gov/dsg/topics/silicacrystalline/index.html>
<http://www.cdc.gov/niosh/docs/96-112/>
<http://oehha.ca.gov/prop65/law/P65law72003.html>
<http://www.dir.ca.gov/Title8/sub4.html>

Your risk from these exposures varies depending on how often you do this type of work. To reduce your exposure to these chemicals, work in a well-ventilated area, and work with approved safety equipment, such as dust masks that are specially designed to filter out microscopic particles. Where use of a dust extraction device is possible, it should be used. To achieve a high level of dust collection, use an industrial HEPA vacuum cleaner. Observe OSHA 29 CFR part 1926.57 and 1926.103.



WARNING

Sawing, grinding and drilling generate dust. Excessive airborne particles may cause irritation to eyes, skin and respiratory tract. To avoid breathing impairment, always employ dust controls and protection suitable to the material being sawed or drilled; See OSHA (29 CFR Part 1910.1200).

ELECTRICAL REQUIREMENTS AND GROUNDING INSTRUCTIONS

In order to prevent electrical shock and injury, the following electrical safety precautions and symbols should be followed at all times!



WARNING

In case of a malfunction or breakdown, grounding provides a path of least resistance for electrical current to reduce the risk of electric shock. This tool is equipped with an electric cord which has an equipment-grounding conductor and a grounding plug. The plug must be plugged into a matching outlet that is properly installed and grounded in accordance with all local codes and ordinances.

- **DO NOT** modify the plug provided - if it will not fit the outlet, have the proper outlet installed by a qualified electrician.
- Improper connections of the equipment-grounding conductor can result in a risk of electric shock. The equipment-grounding conductor is the insulated conductor that has an outer surface that is green, with or without yellow stripes. If repair or replacement of the electric cord or plug is necessary, **DO NOT** connect the equipment-grounding conductor to a live terminal.
- Check with a qualified electrician or service personnel if the grounding instructions are not completely understood, or if in doubt as to whether the tool is properly grounded.
- Use only 3-wire extension cords that have 3-prong grounding plugs and 3-pole receptacles that accept the tool's plug.
- Repair or replace a damaged or worn cord immediately.

This tool is intended for use on a circuit that has an outlet that looks like the one shown in Sketch A. The tool has a grounding plug that looks like the plug illustrated in Sketch A. A temporary adapter, which looks like the adapter illustrated in sketches B and C, may be used to connect this plug to a 2-pole receptacle as shown in Sketch B, if a properly grounded outlet is not available. The temporary adapter should be used only until a properly grounded outlet can be installed by a qualified electrician. The green-colored rigid ear, plug, and the like, extending from the adapter, must be connected to a permanent ground, such as a properly grounded outlet box.

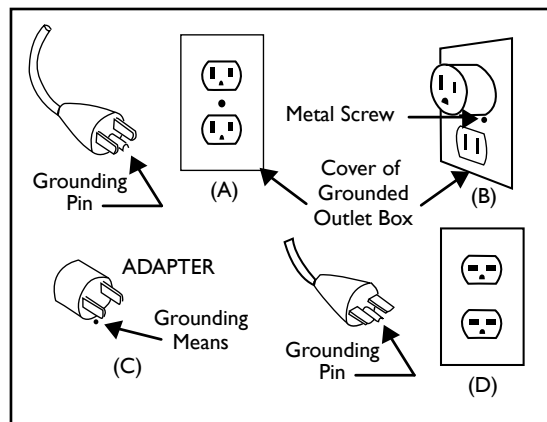

Circuit and Adapter Information

NOTE: Use of a temporary adapter is not permitted in Canada.

NOTE: If permanently connected this tool should be connected to a grounded metal permanent wiring system; or to a system having an equipment - grounding conductor.

ELECTRIC MOTOR SAFETY

For maintenance care and operation of the electric motor, refer to your electric motor instruction booklet furnished with the electric motor. Protect the electric motor from dust as much as possible and keep ventilating openings clean. Before plugging in the machine, make sure that the outlet voltage is within the voltage marked on the machines's data plate.

**CAUTION**

DO NOT spray water on the electric motor. **DO NOT** touch the plug with wet hands. To reduce the risk of electrocution, keep all connections dry and off the ground.



DO NOT operate electric motor in an explosive environment.

**DO NOT EXPOSE TO RAIN**

DO NOT expose to rain or use in damp locations.

**WARNING**

If operating the equipment in damp locations is unavoidable, **ALWAYS** use a Ground Fault Circuit Interrupter, **ALWAYS** wear rubber gloves and footwear in damp conditions.



DO NOT abuse the cord. Never use the cord to carry the equipment or to pull the plug from the outlet. Keep the cord away from heat, sharp edges, and moving parts. Replace damaged cords immediately. Damaged cords increase the risk of electric shock.

**WARNING**

To reduce the risk of electrocution, keep all connections dry and off the ground. A Ground Fault Circuit Interrupter (GFCI) should be provided on the circuit(s) or outlet(s) to be used for this machine. Receptacles are available having built-in GFCI protections and may be used for this measure of safety. When using an extension cord, GFCI should be installed closest to the power source, followed by the extension cord and lastly, the machine.

**WARNING**

The water pump requires a GFCI. To reduce risk of electrical shock when operating the machine with the pump plugged into the 3-pole receptacle on the motor, connect the machine to a GFCI outlet. See the pump manual and informational tags enclosed separately for all pump information.

**WARNING**

To avoid the possibility of the appliance or plug receptacle getting wet, position the machine to one side of a wall mounted receptacle. This will prevent water from dripping into the receptacle or plug. A "drip loop," shown in the picture below, should be arranged by the user to properly position the power cord relative to the power source. Use the drip loop as a way to prevent GFCI and plug from getting wet.

The "drip loop" is that part of the cord below the level of the receptacle (or the connector, if an extension cord is used). This method of positioning the cord prevents the travel of water along the power cord and coming in contact with the receptacle.

If the plug or receptacle gets wet, **DO NOT** unplug the cord. Disconnect the fuse or circuit breaker that supplies power to the tool. Then unplug and examine for presence of water in the receptacle.

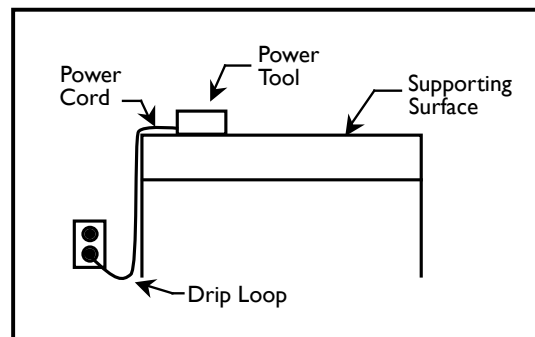

Drip Loop Information

**WARNING**

Use only extension cords that are intended for outdoor use. These extension cords are identified by a marking "Acceptable for use with outdoor appliances; store indoors while not in use." Use only extension cords having an electrical rating not less than the rating of the product. **DO NOT** use damaged extension cords. Examine extension cords before using and replace if damaged. **DO NOT** abuse extension cords and **DO NOT** yank on any cord to disconnect. Keep cords away from heat and sharp edges. Always disconnect the extension cord from the receptacle before disconnecting the product from the extension cord.

ALWAYS make certain that the power source required for the electric motor is correct and always use the correct NEMA configuration plug. Motors can burn out when the line voltage falls 10% below the voltage rating of the motor. Failure to use proper voltage will cause the motor to overheat. Make certain that the correct size grounded (3-wires) extension cord is used.

**WARNING**

Use of undersized extension cords result in low voltage to the motor that can result in motor burnout and premature failure. MK Diamond warns that equipment returned to us showing signs of being run in a low voltage condition, through the use of undersized extension cords, will be repaired or replaced totally at the customer's expense. There will be no warranty claim.

To choose the proper extension cord,

- Locate the length of extension cord needed in the table below.
- Once the proper length is found, move down the column to obtain the correct AWG size required for that length of extension cord.

MOTOR SPECS			EXTENSION CORD LENGTH			
Motor	Voltage	Amps	25'	50'	100'	200'
161099	120V 1 Ph	14.4	12 ga	10 ga	8 ga	•
231095-RW	120V 1 Ph	16.8	12 ga	10 ga	6 ga	•
231095-RW	230V 1 Ph	8.4	14 ga	14 ga	12 ga	10 ga

LOCK OUT METHOD

In order to help prevent accidental starting and to help make your work area "kidproof," this machine is provided with a means to deactivate the functioning of the motor switch. The switch is equipped with a lockout tab that can be used with a lock to prevent movement of the switch. With the switch unable to move the motor cannot be turned on. Removing the lock reactivates the switch.



OPERATION & SAFETY DECALS

The MK-2000 Electric Saws is equipped with a number of safety decals provided for operator safety and maintenance information. Should any of these decals become unreadable, replacements can be obtained by calling (800) 262-1575.

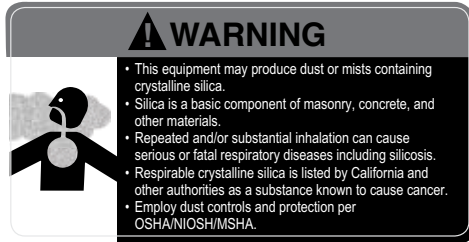

Part # 164202
A

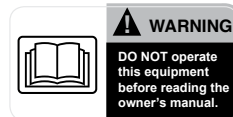

Part # 154398
B



Part # 155678
C

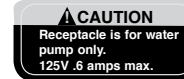

Part # 154822
D



Part # 155038
E



Part # 155587 (2)
F



Part # 155588
G

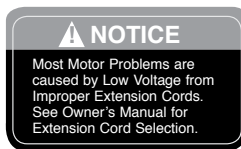

Part # 155672
H



Scan for manuals
Part # 170480
I

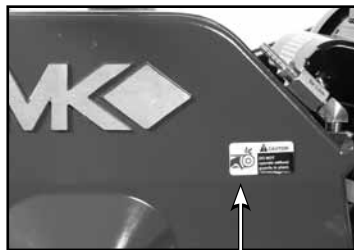

F

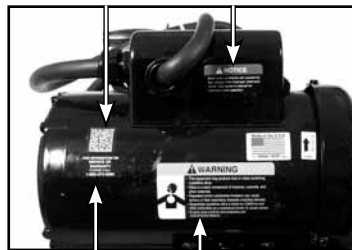

E A

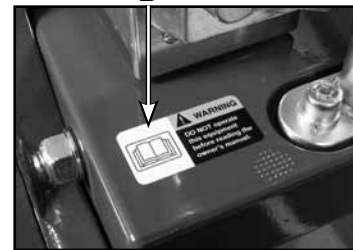

B



H



F



G



C

Decal	Location	Description
A	Motor - Back	Warning - Silica
B	Cutting Head	Warning - Read Manual
C	Motor - Side	Caution - Ground Fault Circuit Interrupter
D	Motor - Side	Caution - Receptacle Water Pump
E	Motor - Back	Service/Warranty
F	Blade Guard	Caution - Guards in Place
F	Belt Guard	Caution - Guards in Place
G	Blade Guard	Warning - Replace Blade Guard
H	Motor - Back	Notice - Extension Cord
I	Motor - Back	QR Code for Manuals

PRODUCT SPECIFICATIONS

Operated and used according to this manual, the MK-2000 Electric Saws will provide years of dependable service.

GENERAL DESCRIPTION

The MK-2000 Electric Saws are engineered as portable brick saws powered by either a 1-1/2 or 2 horsepower electric motor. The saw is capable of cutting masonry up to five (5) inches (127 mm) in height, sixteen (16) inches in length in a single pass.

MOTOR SPECIFICATIONS

Motor specifications for the MK-2000 Electric Saw are listed below.

Model	MK-2001SV	MK-2002
Horse Power	1.5 hp	2.0 hp
Amps	14.4	16.8/8.4
Voltage/Gas	115V	115V / 230V
Overall Amperage	14.4	16.8 a / 8.4 a
Motor RPM	1725	3450
Blade RPM	2540	3100
Weight	157 lbs.	163 lbs
Part #	161195	150598

NOTE: The MK-2000 series is also available with a 50hz motor.

THERMAL OVERLOAD PROTECTION

The motor is protected by a thermal overload equipped with a manual reset.

BLADE CAPACITY

The MK-2000 Electric Saw is designed for use with a 14-inch diameter segmented wet or dry MK Diamond blade with a .110 to .375 inch cutting width.

MASONRY TYPES

The MK-2000 Electric Saw can cut a variety of masonry types including, cinder block, slump stone block, wall brick, paver brick, concrete block and cylinders, roofing tile, marble, granite, decorative rock or almost any other non-ferrous material.

NOTE: The MK-2000 Electric Saw is not designed to cut plastic or metals.

SPRING ASSISTED CUTTING HEAD

The MK-2000 Electric Saw is designed with a spring-assisted cutting head to allow for easier step cutting. The Cutting Head can be locked in the down position when cutting smaller pieces.











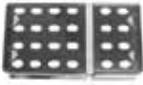

UNPACKING

Your MK-2000 Electric Saw has been shipped from the factory thoroughly inspected. Only minimal assembly is required.

CAUTION Use proper lifting techniques when lifting the MK-2000 Electric Saw.

CONTENTS

In your container, you will find one (1) MK-2000 Electric Saw and water basin, one (1) diamond blade, one (1) MK-2000 Electric Saw movable cutting table, one (1) adjustable cutting guide, one (1) electric water pump, one (1) pump discharge fitting, one (1) cooling transfer tube, one (1) drain plug, one (1) blade wrench, one (1) owners manual, one (1) pump manual and one (1) warranty card.

						
MK-2000 Frame	Diamond Blade	Movable Cutting Table	Adjustable Cutting Guide	Electric Water Pump	Pump Discharge Fitting	Cooling Transfer Tube
						
Drain Plug	Wrench	Owner's Manual	Pump Manual	Warranty Card		

TRANSPORT

CAUTION Lock the Cutting Head in the "DOWN" position and remove the Movable Cutting Table when transporting the MK-2000 Gas Saw.

NOTE: Never transport the MK-2000 Electric Saw with water in the Water Basin. The MK-2000 Electric Saw is designed with recessed handles in the right and left upright castings or forklift brackets on the bottom for ease of transport. Two people are required when transporting saw.

To transport:

- Verify the Movable Cutting Head is locked in the down position and the Movable Cutting Table is removed
- Grasp the saw by the recessed handle in the right and left upright castings
- Grasp the front of the saw
- Lift and transport the saw to the desired work location

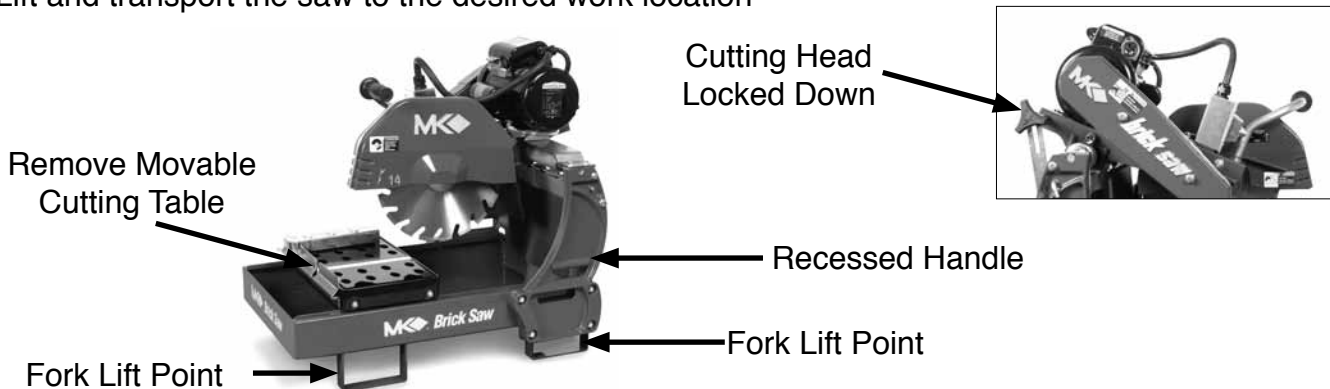

ASSEMBLY (Optional)

NOTE: If using the MK Diamond Stand, follow these steps.



(A)
Open the stand and place it on flat surface.



(B)
Set saw on stand as shown.



(C)
Ensure pins are placed through holes on frame.

MOVABLE CUTTING TABLE INSTALLATION



(A)
While holding the front, position movable Cutting Table roller wheels above Guide Rails.



(B)
Seat movable Cutting Table roller wheels on saw Guide Rails.



(C)
Verify movable Cutting Table is seated correctly by moving table back and forth

ADJUSTABLE CUTTING GUIDE INSTALLATION

NOTE: The adjustable Cutting Guide can be used on either side of the Diamond Blade.



(A)

Loosen adjustable Cutting Guide retaining thumbscrews by turning counter-clockwise.



(B)

Position adjustable Cutting Guide above movable Cutting Table. Align parallel slots. Seat and tighten the adjustable Cutting Guide retaining thumbscrew.

WATER PUMP PREPARATION



(A)

Install Water Pump Discharge Fitting.



(B)

Press one end of the Cooling Transfer Tube into the Water Pump Discharge Fitting.

DIAMOND BLADE INSTALLATION

 CAUTION

NOTE: The Cutting Head is locked in the down position when shipped from the factory.

When installing the diamond blade retaining-bolt, ensure the threads of the bolt are aligned with the threads of the blade shaft so as not to “cross-thread” the bolt.



(A)

While holding cutting head handle loosen the cutting head locking handle by turning counter-clockwise.



(B)

Raise cutting head to the highest position and tighten the locking handle.



(C)

Identify and remove retaining screw and outer flange using the blade wrench. Turn counter-clockwise to loosen.

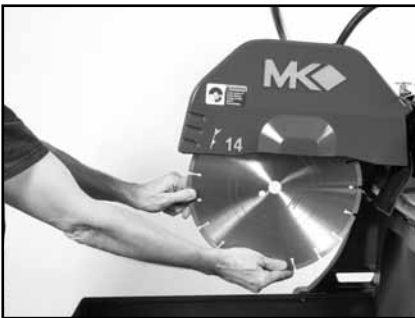

(D)

Install the diamond blade onto the blade shaft with the directional arrow facing out.



(E)

Verify the blade is seated on the blade shaft and the directional arrow are facing out.



(F)

Install outer flange and then retaining screw; tighten screw by rotating the blade wrench clockwise.

PRE-START INSPECTION

Prior to beginning work, a pre-start inspection of the saw should be performed.



(A)
Ensure the ON/OFF switch is in the OFF position.

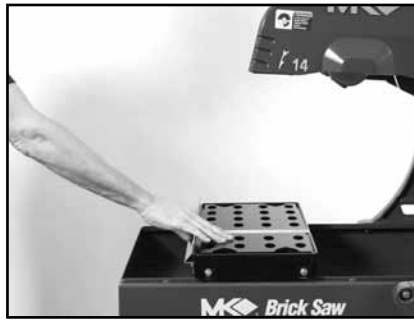

(B)
Verify the Movable Cutting Table moves freely along the guide rails.

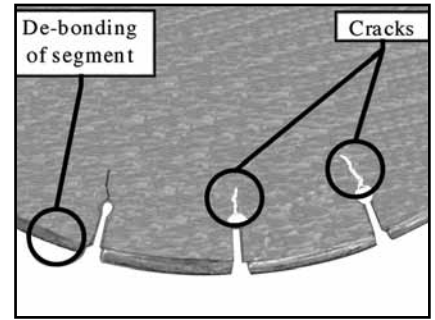

(C)
Inspect the Diamond Blade for damage, cracks and de-bonding; verify the blade is correct for the material being cut.



(D)
Inspect the Pump Assembly for damage - ensure the cord is free of cracks or cuts.



(E)
Inspect the MK-2000 for damage.

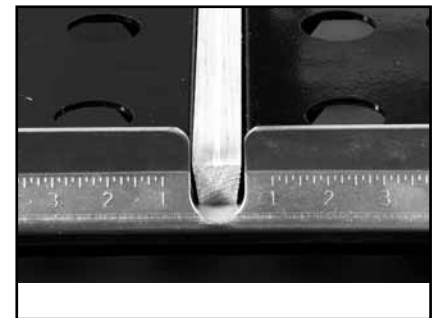

(F)
Inspect the Wooden Protective Strip for excessive grooves.

CONNECTING THE WATER PUMP



CAUTION

NOTE: To prevent pump damage, the Water Pump must be disconnected if cutting with a Dry Blade.



(A)
Insert cooling transfer hose through loop.



(B)
Connect the Cooling Transfer Tube to the inlet connection of the Blade Guard.



(C)
Connect the Water Pump power cord to the receptacle found on motor.

WATER PUMP SETUP FOR OPERATION

The Water Pump can be setup for operation in two ways, External Water Source or Re-circulation.

NOTE: If using a dry blade for operation, DO NOT connect the water pump.

EXTERNAL WATER SOURCE

This is the preferred method of cooling.

1. Verify or remove the Drain Plug from the Water Pan.
2. Place the Water Pump in an external container.
3. Fill the external container until water completely covers the Water Pump suction inlet.
4. Place an external catch basin below the Water Pan drain hole.

RE-CIRCULATION

NOTE: When using the re-circulation method, the water should be changed often for longer pump life.

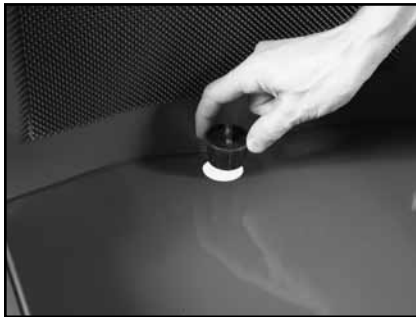

(A)

Install the Drain Plug into the Water Pan.



(B)

Place the Water Pump in the back of the Water Pan. Fill the Water Pan until water completely covers the Water Pump suction inlet.

MK-2000 SETUP FOR OPERATION**CAUTION**

1. Before powering or starting, check for damage that could prevent this equipment from proper operation or performing it's intended function. Check for binding and alignment of moving parts. Check for damaged, broken, or missing parts.
2. Verify the On/Off switch is in the OFF position.
3. Before connecting the MK-2000 to a power supply, be sure the voltage, cycle and phase of the job site power source meet the requirements of table below.
4. If using an extension power cord, make sure the length and wire gauge correspond to the requirements listed in table on page 12. An extension power cord that is too small in wire gauge (diameter), or too long in length, will cause the motor to overheat and could cause premature failure.
5. Do not cover the motor vents as this could lead to motor overheating.

VOLTAGE:	120v/230v
CYCLE:	60hz
PHASE:	1-phase

NOTE: In order to avoid breaker tripping, a 20-amp circuit breaker should be used.

PORTABLE GENERATOR

If using a portable generator to provide power, ensure the generator meets the following minimum requirements:

8 KW	120/240 volts	66.7/33.3 amps	Single Phase
------	---------------	----------------	--------------

CHANGING VOLTAGE SETTING FOR THE MK-2002

Perform the following steps to change voltage setting between 115V and 230V.

CAUTION The power must be removed from the saw before changing the voltage setting.



(A)
Remove the Voltage Change Switch locking nut and bolt using 3/8" and 5/16" wrenches.



(B)
Move the Voltage Change Switch to the desired voltage setting.



(B)
Reinstall the locking bolt and replace the nut.

DUAL VOLTAGE

WARNING FOR DUAL VOLTAGE MODELS ONLY ! The MK-2000 motor has 2 voltage positions, 115v and 230v. Ensure the Voltage Adjustment Switch of the MK-2000 motor is set for the voltage of the intended power source BEFORE installing the MK-2000 Power cord.

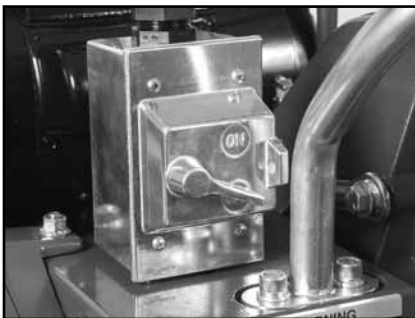

(A)
Ensure the ON/OFF Switch is in the OFF position



(B)
Verify or place the Voltage Adjustment Switch in the correct voltage position.

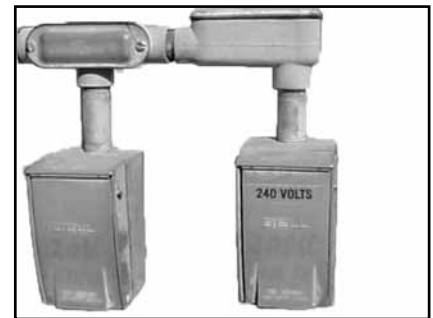

(C)
Locate the correct power source for the setting of the MK-2000 Voltage Adjustment Switch.

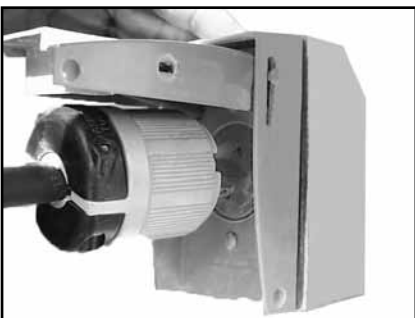

(D)
Align, install and twist clockwise to lock the polarized plug of the MK-2000 into the correct power source.

STEP CUTS

A Step Cut is performed when a series of small cuts of increasing depth are used to complete a single cut. Step Cuts are used for large objects or for hard objects such as Firebrick and Pavers.

- NOTE:**
- Step Cutting is the preferred cutting method for all cuts.
 - When cutting hard material Step Cutting should always be used.
 - Step Cutting will extend the life of the Diamond Blade.

NOTE: Skip steps E and F, if cutting dry.

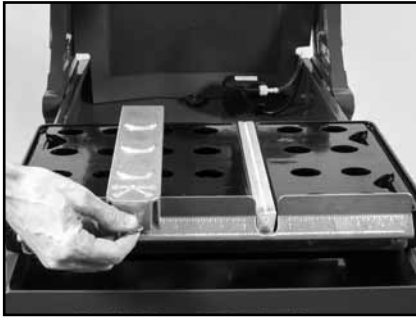

(A)

Set the adjustable Cutting Guide to the desired length indicated on the side of the Ruler/Stop closest to the Wooden Strip. Tighten thumbscrew.

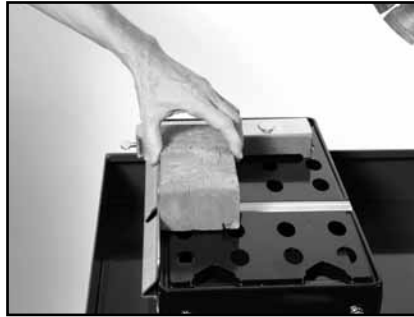

(B)

Place the masonry piece onto the Movable Cutting Table.

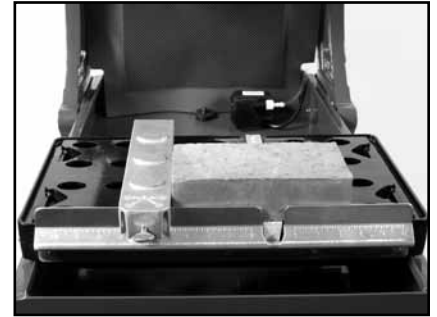

(C)

Verify the masonry piece is seated against the Ruler/Stop and the adjustable Cutting Guide.



(D)

Place the ON/OFF Switch in the ON position.



(E)

Open the Cooling Flow Control Valve and adjust cooling flow. Verify cooling flow exists on both sides of the blade.

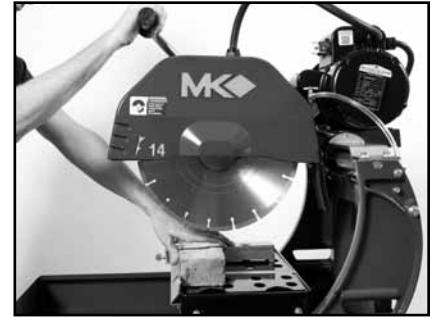

(F)

Position the masonry piece below the Blade.

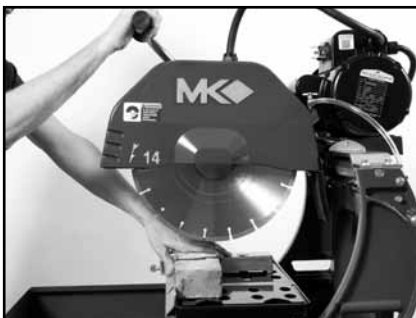

(G)

Hold the masonry piece, lower the Cutting Head and "PUSH" the piece toward the Blade. Lower 1/4 - 1/2 inch for "push" stroke.

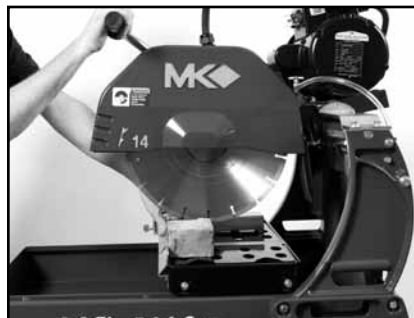

(H)

Once the "PUSH" cut is complete, lower the Cutting Head further and "PULL" the piece back into the Blade.

CAUTION

Cut in smooth even strokes; do not force the saw to cut.

Repeat F and G until cutting is complete. Turn off saw when cut is complete.

CHOP CUTTING

A Chop Cut is performed by cutting completely through an object in one pass.

NOTE: Skip step E, if cutting dry.



(A)

Set the adjustable Cutting Guide to the desired length indicated on the side of the Ruler/Stop closest to the Wooden Strip. Tighten thumbscrew.

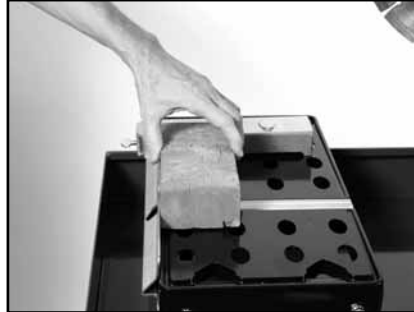

(B)

Place the masonry piece onto the movable Cutting Table.

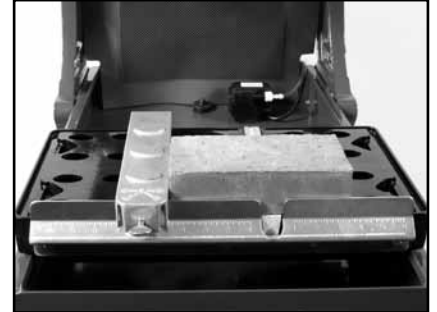

(C)

Verify the masonry piece is seated against the Ruler/Stop and the adjustable Cutting Guide.



(D)

Place the ON/OFF Switch in the ON position.



(E)

Open the Cooling Flow Control Valve and adjust cooling flow. Verify cooling flow exists on both sides of the blade.

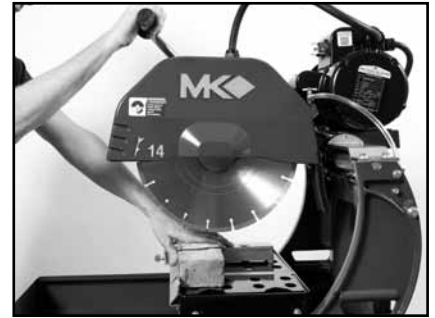

(F)

Position the masonry piece below the Blade.



CAUTION

Cut in smooth even strokes; do not force the saw to cut.

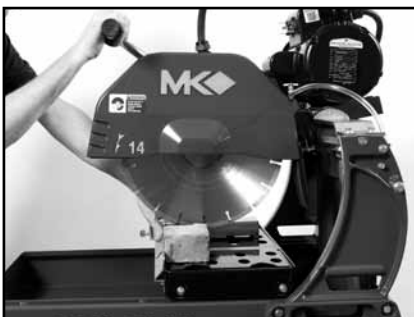

(G)

Lower the Cutting Head to begin the cut.

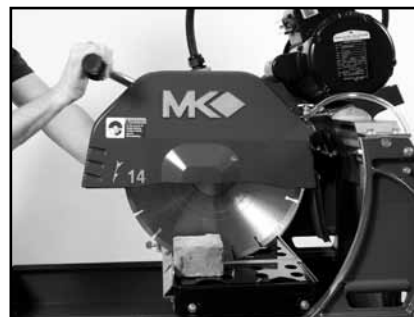

(H)

Continue lowering the Cutting Head until the cut is complete; raise the cutting head when the cut is complete. Turn off the machine.

CUTTING WITH THE CUTTING HEAD LOCKED DOWN

This method is preferred when cutting small objects.



CAUTION Cut in smooth even strokes; do not force the saw to cut.



(A)

Loosen the Cutting Head Locking Handle. Lower the Cutting Head until the Blade touches the protective Wooden Strip.



(B)

Lock the Cutting Head in the "Down" position using the Locking Handle. Turn clockwise to tighten.



(B)

Move the cutting table to position the brick in front of the blade. Slowly push piece into the blade and continue pushing until the cut is complete. Turn off machine.

ANGLE CUTS

Angle Cuts may be performed by using any cutting method. The following example uses the Step Cut method.



CAUTION Cut in smooth even strokes; do not force the saw to cut.

NOTE: Skip steps C and D, if cutting dry.

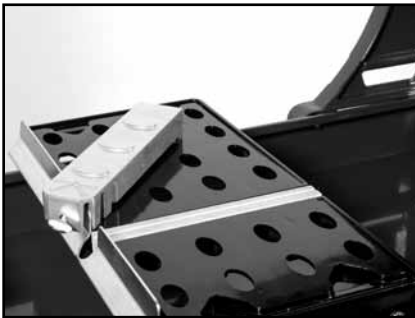

(A)

Reposition the adjustable Cutting Guide to the 45° cutting position

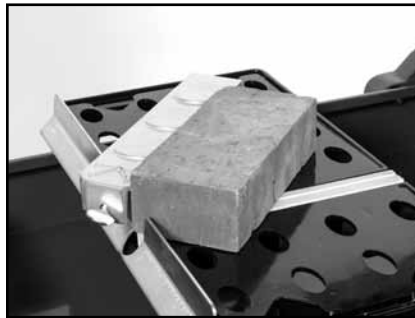

(B)

Position the masonry piece and adjustable Cutting Guide to the desired cut length. Tighten thumbscrew.



(C)

Turn ON machine. Open the Cooling Flow Control Valve and adjust cooling flow. Verify cooling flow exists on both sides of the blade.

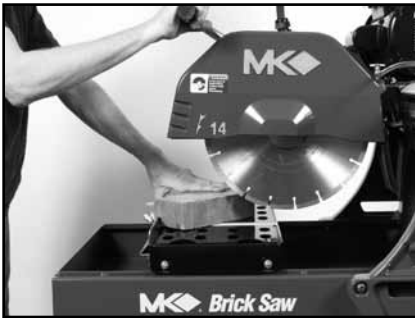

(D)

Hold the masonry piece, lower the Cutting Head and “push” the piece toward the Blade. Lower 1/4" - 1/2" for “push” stroke.

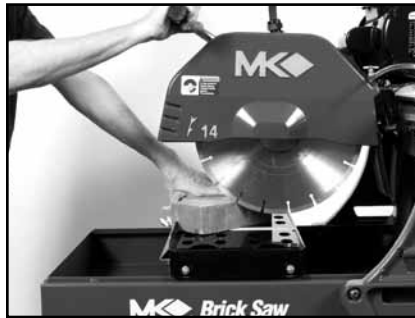

(E)

Once the “push” cut is complete, lower the Cutting Head further and “pull” the piece back into the blade. Turn OFF saw when cut is complete.

Repeat steps E and F until cutting is complete. Turn off machine.

PUMP CLEANUP

(A)

Clean the Water Pump suction of all debris.



(B)

Place the Water Pump in an external container. Run the MK-2000 until clear water is seen at the Blade cooling ports (Approx. 1 minute).

**CAUTION**

Ensure the saw is disconnected before completing the remainder of the cleanup process.

Ensure water is not forced into the motor casing when cleaning.

CUTTING TABLE CLEANUP

(A)

Clean the Movable Cutting Table Guide Rails.



(B)

Clean the Movable Cutting Table Roller Wheels. Clean the remainder of the MK-2000.

NEW MAINTENANCE

Perform the following after initial purchase and operation of the MK-2000

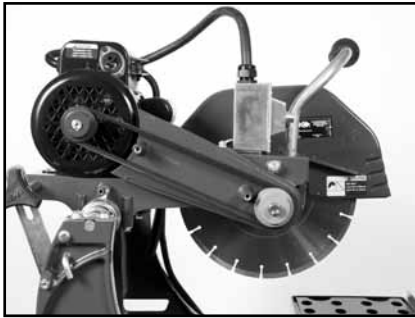

(A)

Check and adjust belt tension following the first 48 hours of operation (See Belt Inspection page 30).

MAINTENANCE FOLLOWING USE

To extend the life of the MK-2000, the following procedure should be performed after each use. Lubricate all points listed below with light oils such as, 3 in 1, WD-40, etc.



(A)

Turn OFF saw and remove Cutting Table. Lubricate the Roller Wheels.



(B)

Lubricate the three Blade Guard Pivot Points.



(C)

Lubricate the Cutting Head Pivot Points.

MONTHLY MAINTENANCE

The following maintenance should be performed monthly.



(A)
Clean the Outer Flange and Retaining Screw.



(B)
Lubricate the Retaining Screw and Retaining Screw Hole.



(C)
Clean the remainder of the MK-2000. Verify all Motor Mounting Bolts are tight.



(D)
Verify the Motor Adjustment Strap is tight.

BLADE DRESSING

Like most cutting instruments, a diamond blade performs best when it is dressed. Over time and use, diamonds on the outer edge of the blade will become smoothed or “glazed” over. This will reduce grinding efficiency and may cause the blade to “wander” or bend giving the illusion of an alignment problem. When this occurs, the blade will need to be dressed. The diamond blade can be dressed using the MK Dressing Stick (part number 152792) and by following the steps below.

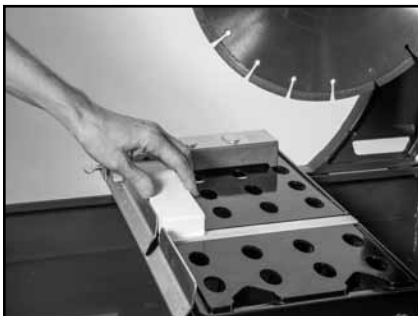

(A)
Position the Dressing Stick against the Adjustable Cutting Guide and the Ruler/Stop.

- Setup the MK-2000 for operation. Set the Adjustable Cutting Guide to cut a 1/16-strip.
- Place the ON/OFF Switch in the ON position. Verify cooling flow exists on both sides of the blade.
- Cut the dressing stick 7 or 8 times to dress the blade.
- Turn the Saw off when cutting is complete.

MOVEABLE CUTTING TABLE WHEEL CHANGE OUT

NOTE: All four (4) Movable Cutting Table Roller Wheels should be replaced at the same time (MK Diamond Part # 133090)



(A)

Remove the Movable Cutting Table. Using a 1/2 inch wrench, remove the Roller Wheel Retaining Nut and Roller Wheel. Rotate counter-clockwise to loosen.



(B)

Clean the Roller Wheel Shaft Holes.



(C)

Install the Wheel/Washer Assembly into Movable Cutting Table Wheel Shaft Hole and tighten. Lubricate the wheels.

PROTECTIVE WOODEN STRIP REPLACEMENT

The protective wooden strip is to protect the Movable Cutting Table from damage during operation. Over time, the wooden strip will become grooved from use. A grooved wooden strip will not support masonry during cutting causing the blade to “break through” the piece instead of performing a smooth cut (MK Diamond Part No. 158283).



(A)

Turn the cutting table upside down. Remove the two Protective Wooden Strip Retaining Screws using a Phillips Screwdriver.



(B)

Replace the worn Protective Wooden Strip with the new Protective Wooden Strip. Reinstall the Retaining Screws.

BELT INSPECTION, ADJUSTMENT & REPLACEMENT

The MK-2000 is designed with a power transmission belt. In order to ensure the MK-2000 operates at peak efficiency, the belt should be inspected monthly, and changed if the belt shows damage and/or excessive wear.

NOTE: When a new belt is installed, it should be inspected and re-tensioned after the first forty-eight (48) hours of operation.



(A)

Turn OFF saw and unplug. Remove the Blade.

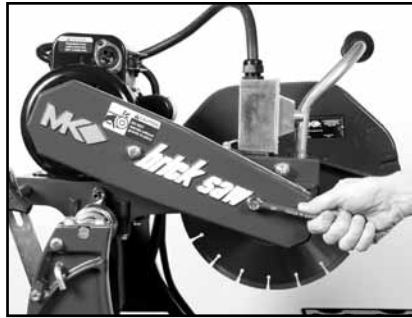

(B)

Remove the two Belt Guard Retaining Screws and the Belt Guard using a 1/2-inch wrench and rotate counter-clockwise to loosen. Remove Belt Guard.

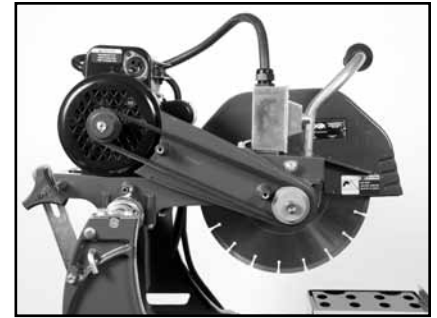

(C)

Inspect the belt for cracks, fraying, separation and wear.

BELT INSPECTION

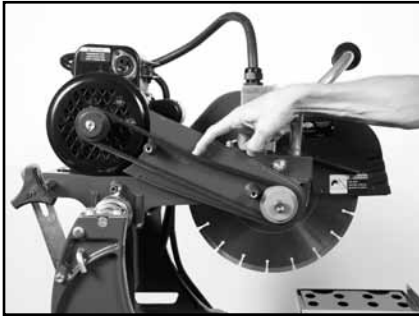

(A)

Check the belt for proper tension. Proper tension 1/8-inch deflection.

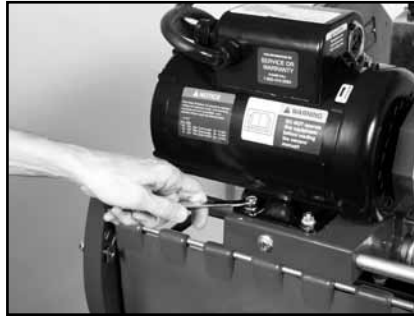

(B)

Loosen the Motor Mounting Bolts using a 1/2 inch wrench; if retensioning only go to step F.



(C)

Loosen the Motor Adjustment Strap using a 9/16-inch wrench.

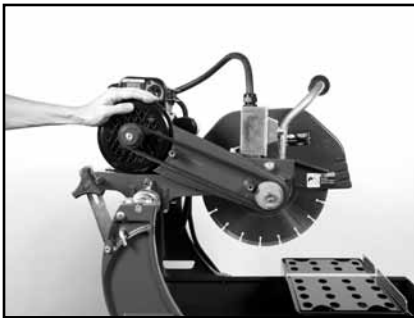

(D)

Push the Motor forward to loosen the belt. Remove the old Belt. Install the new belt.

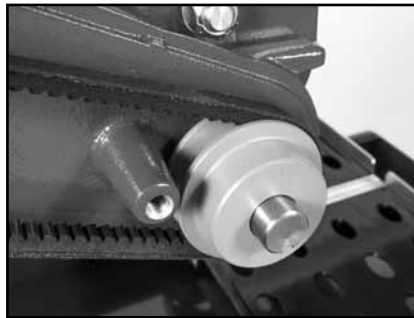

(E)

Verify the belt is seated in the grooves of both pulleys.

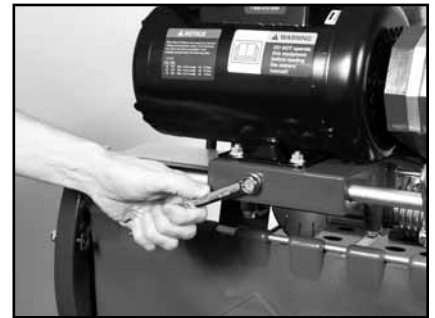

(F)

Tighten the Motor Adjustment Strap using a 9/16-inch wrench to remove slack.



(G)

Install the Belt Guard.

MK-2002 Saw Assembly Part # 150598

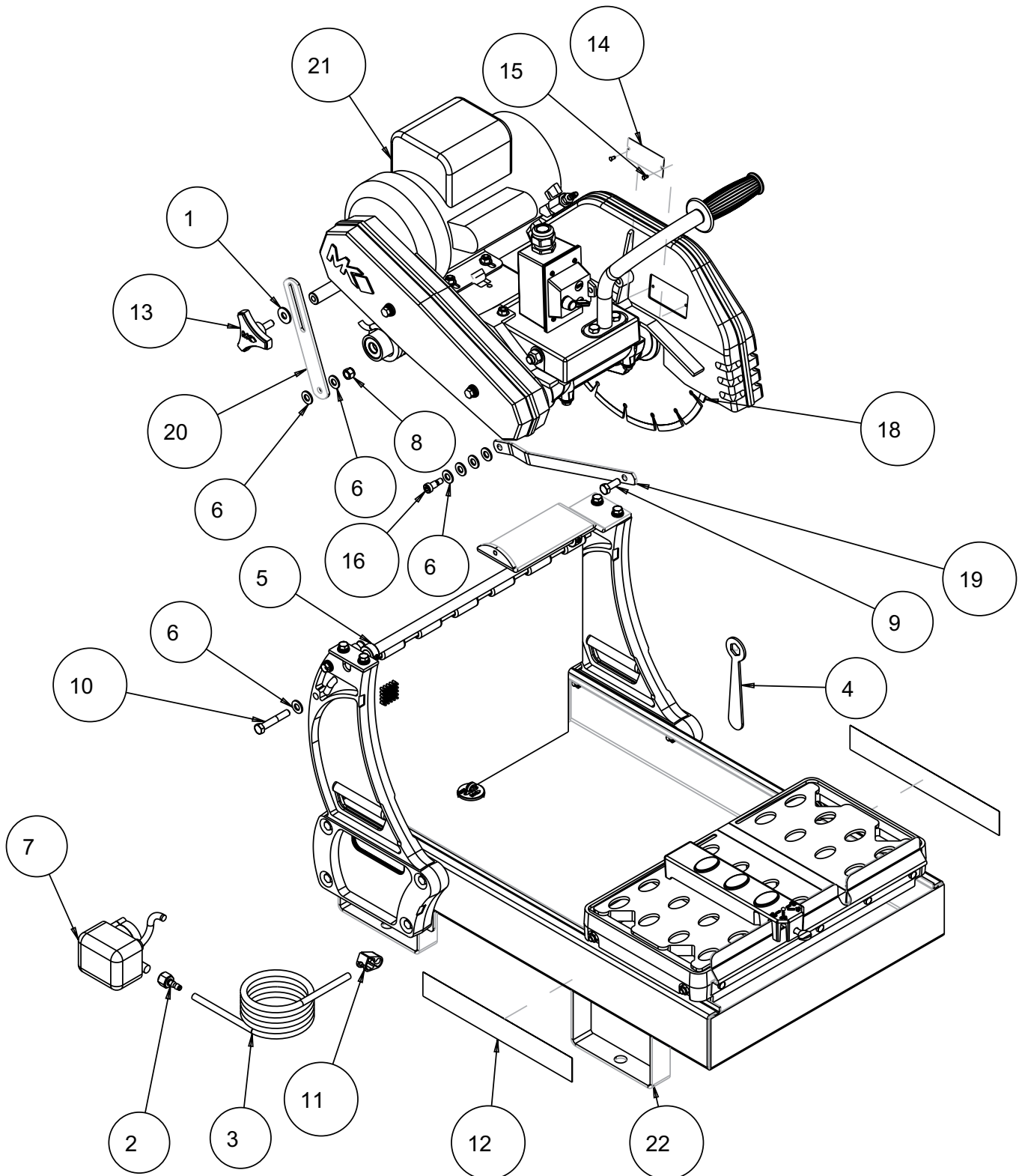

MK-2002 Saw Assembly Part # 150598

ITEM	DESCRIPTION	PART #	QTY.
1	WASHER, FLAT, USS, 3/8	101360	1
2	FITTING, PLASTIC, 1/4 FNPTX1/4 BARB	128397	1
3	HOSE, VINYL, 1/4X3/8 (32.0')	132951	1
4	WRENCH, 3/4 BOX END	134056	1
5	COLLAR, 1.13 ODX 625ID .5 WIDE	140012	2
6	WASHER, FLAT, SAE, 3/8	150923	7
7	PUMP, WATER, G-150A	151271	1
8	NUT, HEX, NYLK, 3/8-16	152505	1
9	SCREW, HEX HD CAP, 3/8-16 X 1	152507	1
10	SCREW, 3/8-16 X 2-1/4 HEX HEAD	153529	1
11	CLAMP, HOSE, 1/4-1/2 FLOW	154394	1
12	LABEL, MK BRICKSAW 12-1/2X1-3/4	155230	2
13	KNOB, TRI PLASTIC, 1"	156770-01	1
14	TAG, SERIAL NUMBER, BLANK	157500-RW	1
15	SCREW, DRIVE, RND HD, #7X5/16	157849	2
16	SCREW, SHOULDER 3/8 X 1/2	160078	1
17	MASONRY LABEL SHEET (NOT SHOWN)	166011	1
18	BLADE, CG, 14X125X1 10MM	166308	1
19	BAR, BLADE GUARD ADJ.	166602	1
20	BRACKET, HEIGHT ADJUSTMENT	166868	1
21	ASSY, CUTTING HEAD, 1.5 HP, 14"	170815	1
22	ASSY, FRAME, 2000	170818	1

MK-2001SV Saw Assembly Part # 161195

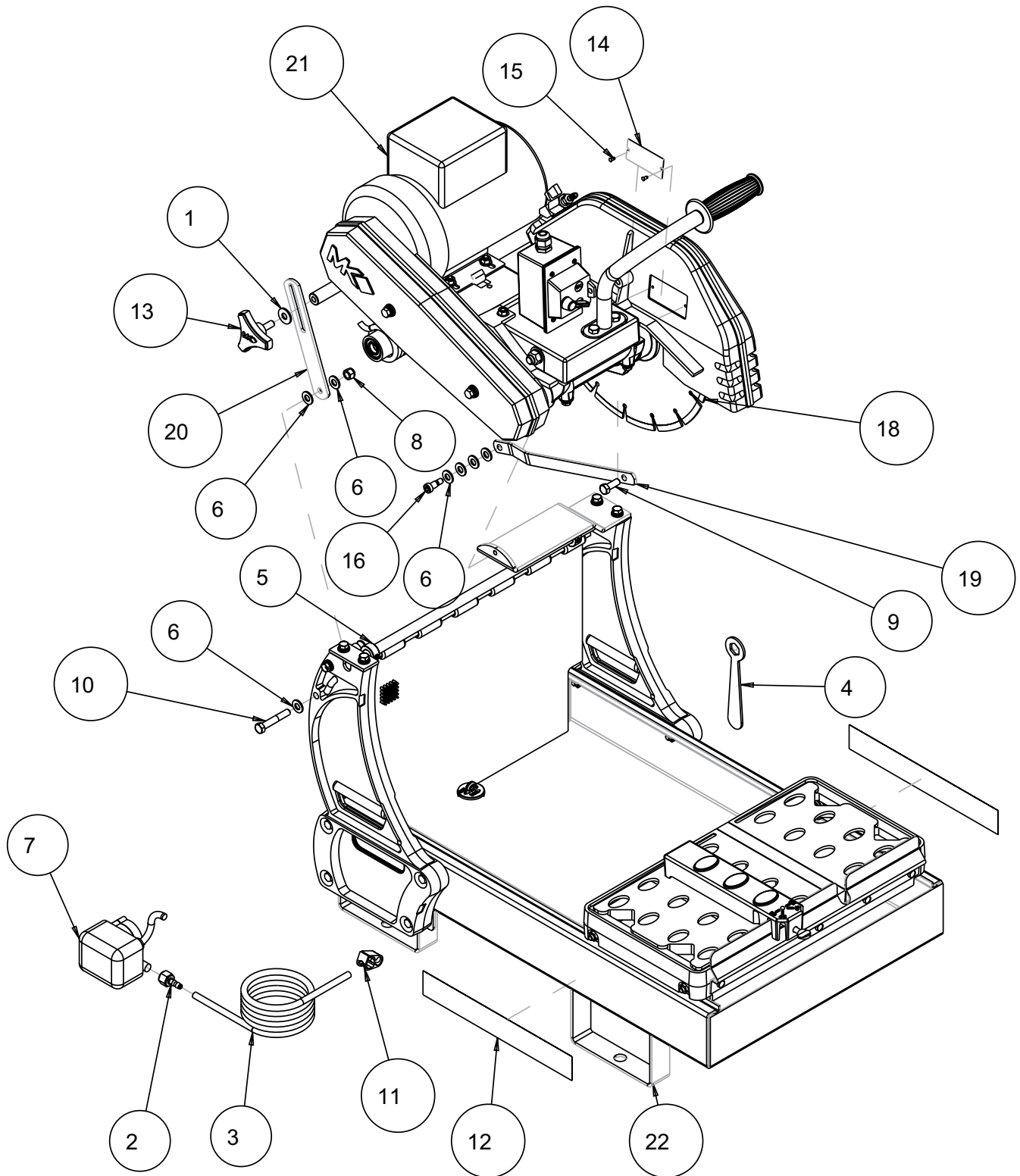

MK-2001SV Saw Assembly Part # 161195

ITEM	DESCRIPTION	PART #	QTY.
1	WASHER, FLAT, USS, 3/8	101360	1
2	FITTING, PLASTIC, 1/4 FNPTX1/4 BARB	128397	1
3	HOSE, VINYL, 1/4X3/8 (32.0')	132951	1
4	WRENCH, 3/4 BOX END	134056	1
5	COLLAR, 1.13 ODX 625ID .5 WIDE	140012	2
6	WASHER, FLAT, SAE, 3/8	150923	7
7	PUMP, WATER, G-150A	151271	1
8	NUT, HEX, NYLK, 3/8-16	152505	1
9	SCREW, HEX HD CAP, 3/8-16 X 1	152507	1
10	SCREW, 3/8-16 X 2-1/4 HEX HEAD	153529	1
11	CLAMP, HOSE, 1/4-1/2 FLOW	152394	1
12	LABEL, MK BRICKSAW 12-1/2X1-3/4	155230	2
13	KNOB, TRI PLASTIC, 1"	156770-01	1
14	TAG, SERIAL NUMBER, BLANK	157500-RW	1
15	SCREW, DRIVE, RND HD, #7X5/16	157849	2
16	SCREW, SHOULDER 3/8 X 1/2	160078	1
17	MASONRY LABEL SHEET (NOT SHOWN)	166011	1
18	BLADE, CG, 14X125X1 10MM	166308	1
19	BAR, BLADE GUARD ADJ.	166602	1
20	BRACKET, HEIGHT ADJUSTMENT	166868	1
21	ASSY, CUTTING HEAD, 1.5 HP, 14"	170813	1
22	ASSY, FRAME, 2000	170818	1

Assy. Cutting Head, 1.5 HP, 14" Part # 170813

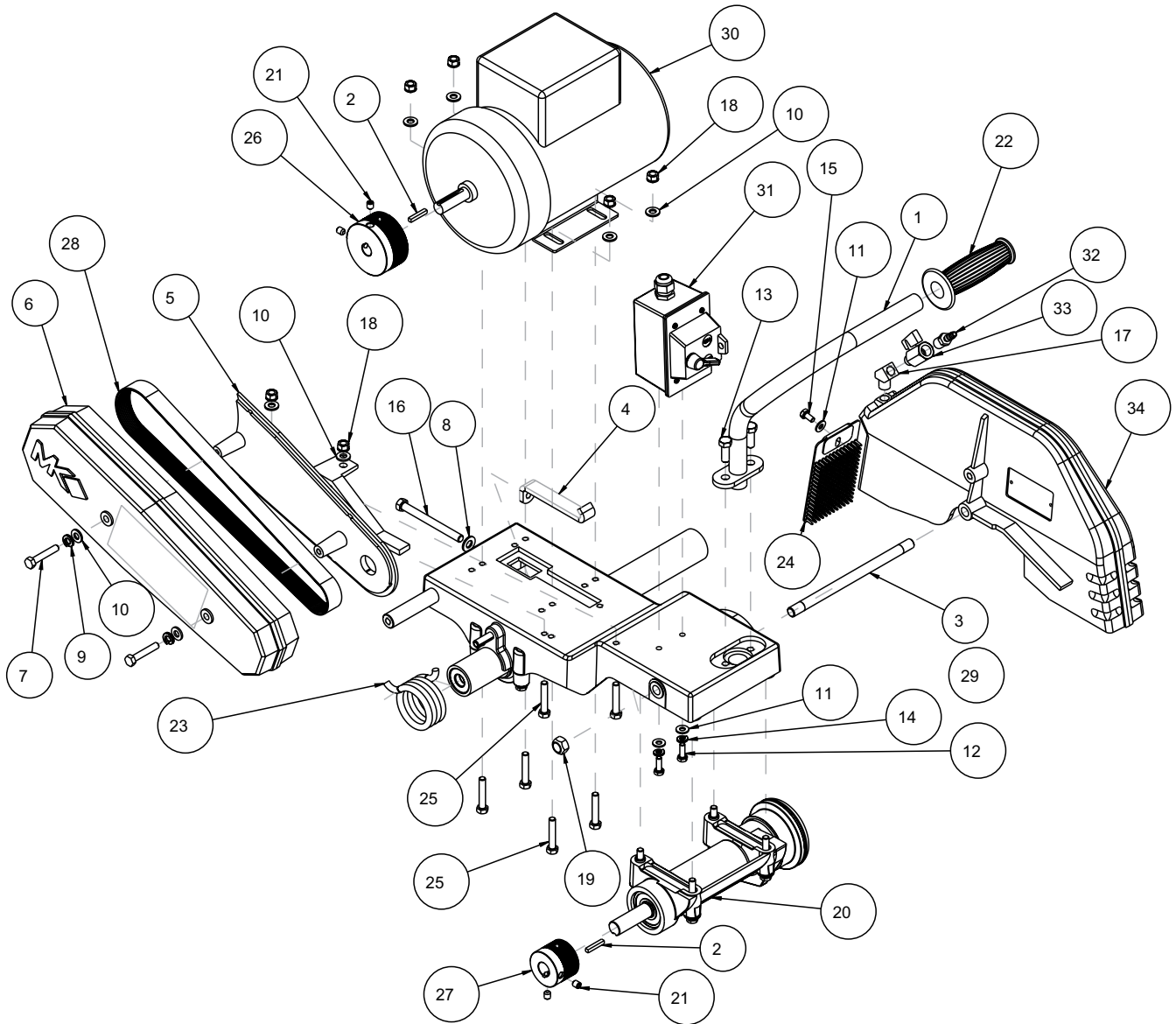

Assy. Cutting Head, 1.5 HP, 14" Part # 170813

ITEM	DESCRIPTION	PART #	QTY.
1	HANDLE, BRICKSAW	139931	1
2	KEY, 3/16 SQ X 1-1/8	150344	2
3	STUD, BLD GUARD	150581	1
4	STRAP, MOTOR ADJ	150584	1
5	CASTING, 2000, BLT GRD INNR-COMP	150590	1
6	BLT GRD OUTR-COMP	150591	1
7	SCREW, HEX HD, CAP, 5/16-18X1-3/4	150919	2
8	WASHER, FLAT, SAE, 3/8	150923	1
9	WASHER, LOCK, SPLIT, 5/16	151747	2
10	WASHER, FLAT, SAE, 5/16	151754	8
11	WASHER, FLAT, SAE, 1/4	151915	3
12	SCREW, HEX HD, 1/4-20X3/4	152370	2
13	SCREW, HEX HD CAP, 3/8-16 X 1	152507	2
14	WASHER, LOCK, SPLIT, 1/4	152591	2
15	SCREW, 1/4-20 X 1/2 HEX HEAD	152608	1
16	BOLT, 3/8-16 X 4 HEX HEAD TAP	152678	1
17	ELBOW, 1/4 NPT X 45 STREET	153869	1
18	NUT, HEX, TW 5/16-18	153942	6
19	NUT, 1/2-13 HEX	153943	1
20	ASSY, ARBOR, MK-2000	154636	1
21	SCREW, 5/16-18 X 3/8 SOCKET HEAD SET	157083	4
22	GRIP, HANDLE 7/8 ID	158608	1
23	SPRING, TORSION, 50 DEG	160069	1
24	GUARD, SPLASH	160310	1
25	SCREW, 5/16-18 X 1-3/4 HEX HEAD MACHINE	160948	6
26	PULLEY, 10J28 X 5/8 BORE	160949	1
27	PULLEY, 10J19 X .75 BORE	160950	1
28	BELT, 10J340	160952	1
29	ASSY, MOTOR MOUNT, MK-2000	160966	1
30	MOTOR, 1.5HP 60HZ 1725R.P.M. 1 PH	161099	1
31	ASSY, SWITCH BOX, 30AMP, LTF11	161101	1
32	FITTING, PUSH ON HOSE 1/4 X 1/4 MALE	165183	1
33	VALVE, BALL 1/4"M X 1/4"F	231248	1
34	CASTING, 2000, BLD GRD-COMP	150579G	1

Assy. Cutting Head, 2 HP, 14" Part # 170815

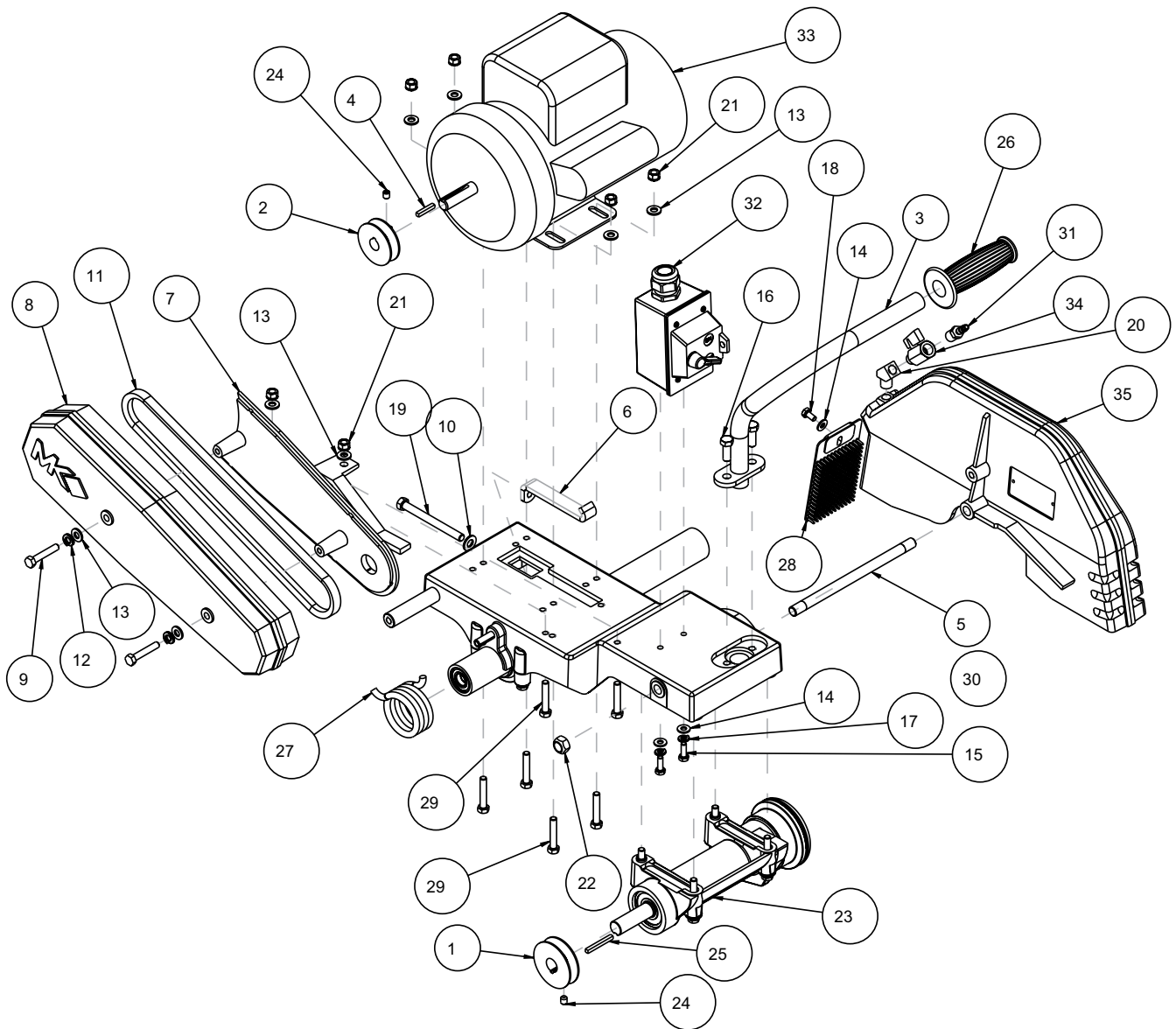

Assy. Cutting Head, 2 HP, 14" Part # 170815

ITEM	DESCRIPTION	PART #	QTY.
1	PULLEY, 1A22 X 5/8" BORE	133140	1
2	PULLEY, 1A22 X 5/8" BORE	133157	1
3	HANDLE, BRICKSAW	139931	1
4	KEY, 3/16 SQ X 1-1/8	150344	1
5	STUD, BLD GUARD	150581	1
6	STRAP, MOTOR ADJ	150584	1
7	CASTING, 2000, BLTGRD INNR-COMP	150590	1
8	BLT GRD OTR-COMP	150591	1
9	SCREW, HEX HD, CAP, 5/16-18X1-3/4	150919	2
10	WASHER, FLAT, SAE, 3/8	150923	1
11	BELT, AX32	151723	1
12	WASHER, LOCK, SPLIT, 5/16	151747	2
13	WASHER, FLAT, SAE, 5/16	151754	8
14	WASHER, FLAT, SAE, 1/4	151915	3
15	SCREW, HEX HD, 1/4-20X3/4	152370	2
16	SCREW, HEX HD CAP, 3/8-16 X 1	152507	2
17	WASHER, LOCK, SPLIT, 1/4	152591	2
18	SCREW, 1/4-20 X 1/2 HEX HEAD	152608	1
19	BOLT, 3/8-16 X 4 HEX HEAD TAP	152678	1
20	ELBOW, 1/4 NPT X 45 STREET	153869	1
21	NUT, HEX, TW, 5/16-18	153942	6
22	NUT, 1/2-13 HEX	153943	1
23	ASSY, ARBOR, MK-2000	154636	1
24	SCREW, 5/16-18 X 3/8 SOCKET HEAD SET	157083	2
25	KEY, 3/16 X 3/16 X 1-3/4	157561	1
26	GRIP, HANDLE 7/8 ID	158608	1
27	SPRING, TORSION, 50 DEG	160069	1
28	GUARD, SPLASH	160310	1
29	SCREW, 5/16-18 X 1-3/4 HEX HEAD MACHINE	160948	6
30	ASSY, MOTOR MOUNT, MK-2000	160966	1
31	FITTING, PUSH ON HOSE 1/4 X 1/4 MALE	165183	1
32	ASSY, 30A SWITCHBOX, LTF21	166022	1
33	MTR, 2HP 115/230V60HZ, NO SWITCH	231095-RW	1
34	VALVE, BALL 1/4"M X 1/4"F	231248	1
35	CASTING, 2000, BLD GRD-COMP	150579G	1

Assy. Frame Part # 170818

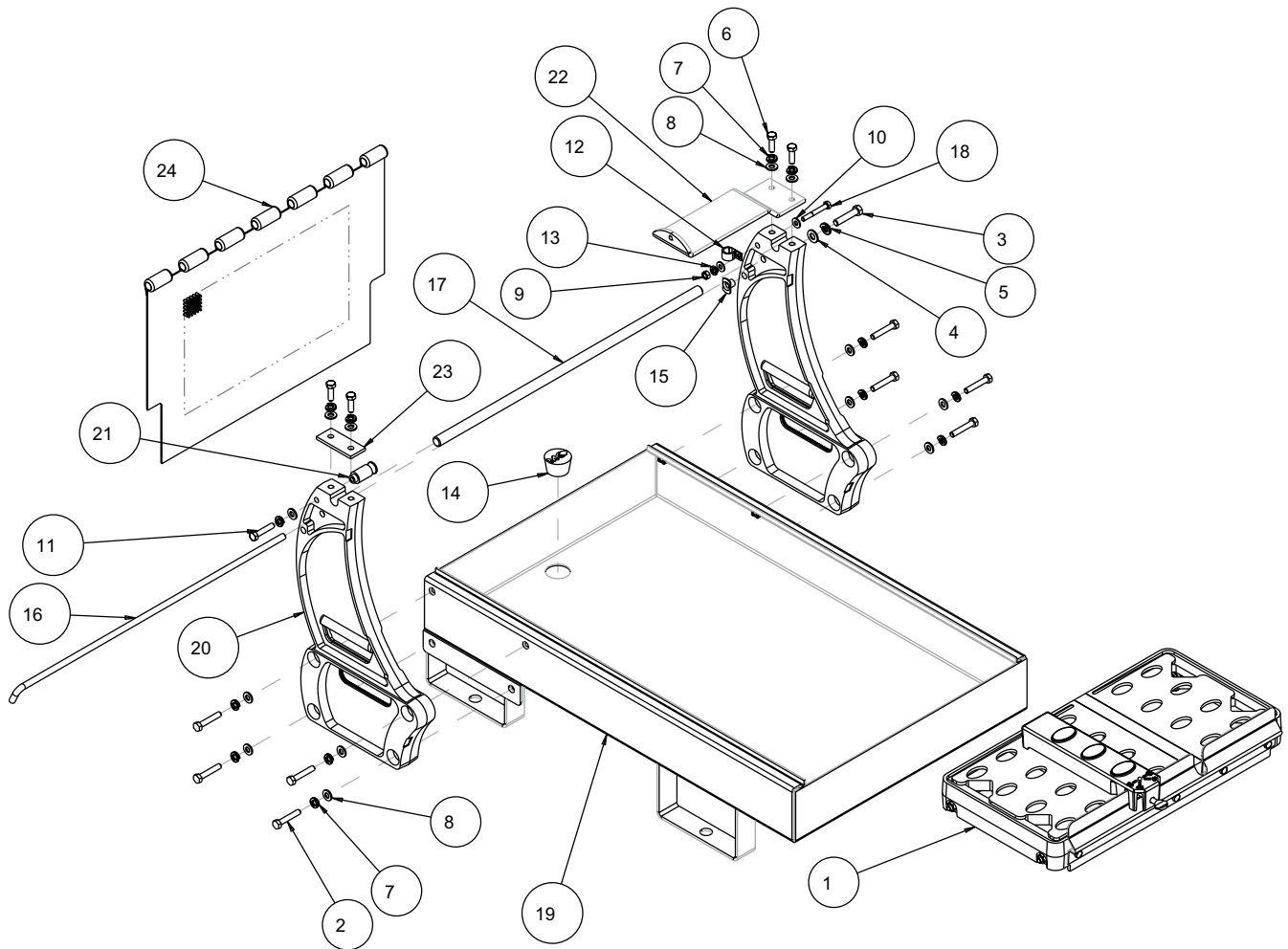

Assy. Frame Part # 170818

ITEM	DESCRIPTION	PART #	QTY.
1	ASSY, CONVYR CART	133082	1
2	SCREW, HEX HD, CAP, 5/16-18X1-3/4	150919	8
3	SCREW, HEX HD, 3/8-16 X 1-3/4	150920	1
4	WASHER, FLAT, SAE, 3/8	150923	1
5	WASHER, LOCK, SPLIT, 3/8	150925	1
6	SCREW, HEX HD, 5/16-18X1	151743	4
7	WASHER, LOCK, SPLIT, 5/16	151747	13
8	WASHER, FLAT, SAE, 5/16	151754	13
9	NUT, HEX, 1/4-20	151893	1
10	WASHER, FLAT, SAE, 1/4	151915	2
11	SCREW, 5/16-18 X 1-1/2 HEX HEAD MACHINE	152467	1
12	CLAMP, 1/2 CUSHION LOOP	152471	1
13	WASHER, LOCK, SPLIT, 1/4	152591	1
14	PLUG, RBBR DRAIN W/O HOLE	153439	1
15	NUT, WELD, SLAB. 3/8-16	153945	1
16	ROD, SPLASH CURTAIN	153956	1
17	SHAFT, PIVOT, 5/8	154147	1
18	SCREW, HEX HD 1/4-20 X 2	158282	1
19	WELDMENT, BASE FRAME	158845	1
20	POST (COMP)	158846	2
21	STUD, SPRING RETAINING	160066	1
22	BRACKET, STAY LEVEL CLIPPER PAV	160068	1
23	BRACKET, PIVOT SHAFT	160070	1
24	CURTAIN, SPLASH, MK-2000	160972	1

Motor Mount Part # 160966

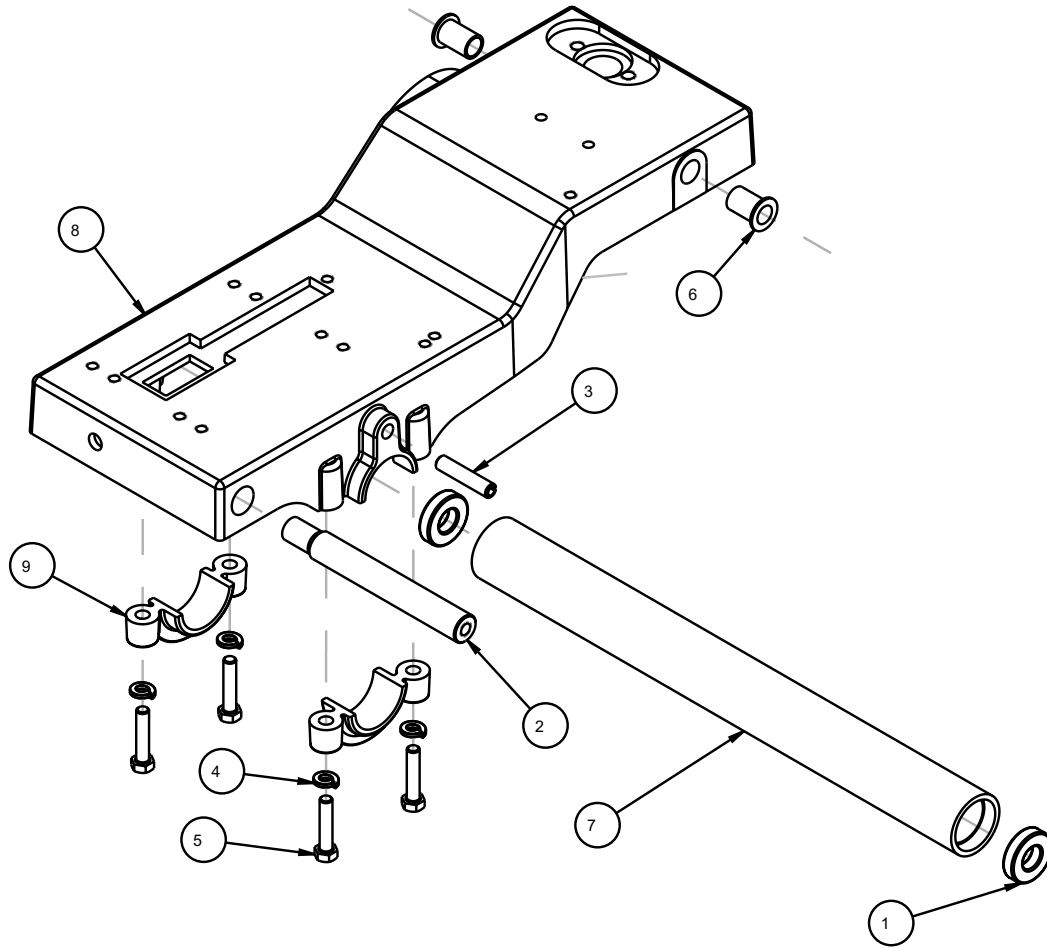

ITEM	DESCRIPTION	PART #	QTY.
1	BEARING, CUTTING HD PIV	140004	2
2	BAR, ADJUSTMENT	150585	1
3	PIN, SLOTTED SPRING, 3/8 X 1-3/4	151358	1
4	WASHER, LOCK, SPLIT, 5/16	151747	4
5	SCREW, 5/16-18 X 1-1/2 HEX HEAD MACHINE	152467	4
6	BUSHING, FLANGE, 1/2X5/8X1	156441	2
7	HOUSING, PIVOT SHAFT	157979	1
8	HEAD, CUTTING (COMP)	160346	1
9	CLAMP, CUTTING HEAD (COMP)	160397	2

Assy. Arbor Part # 154636

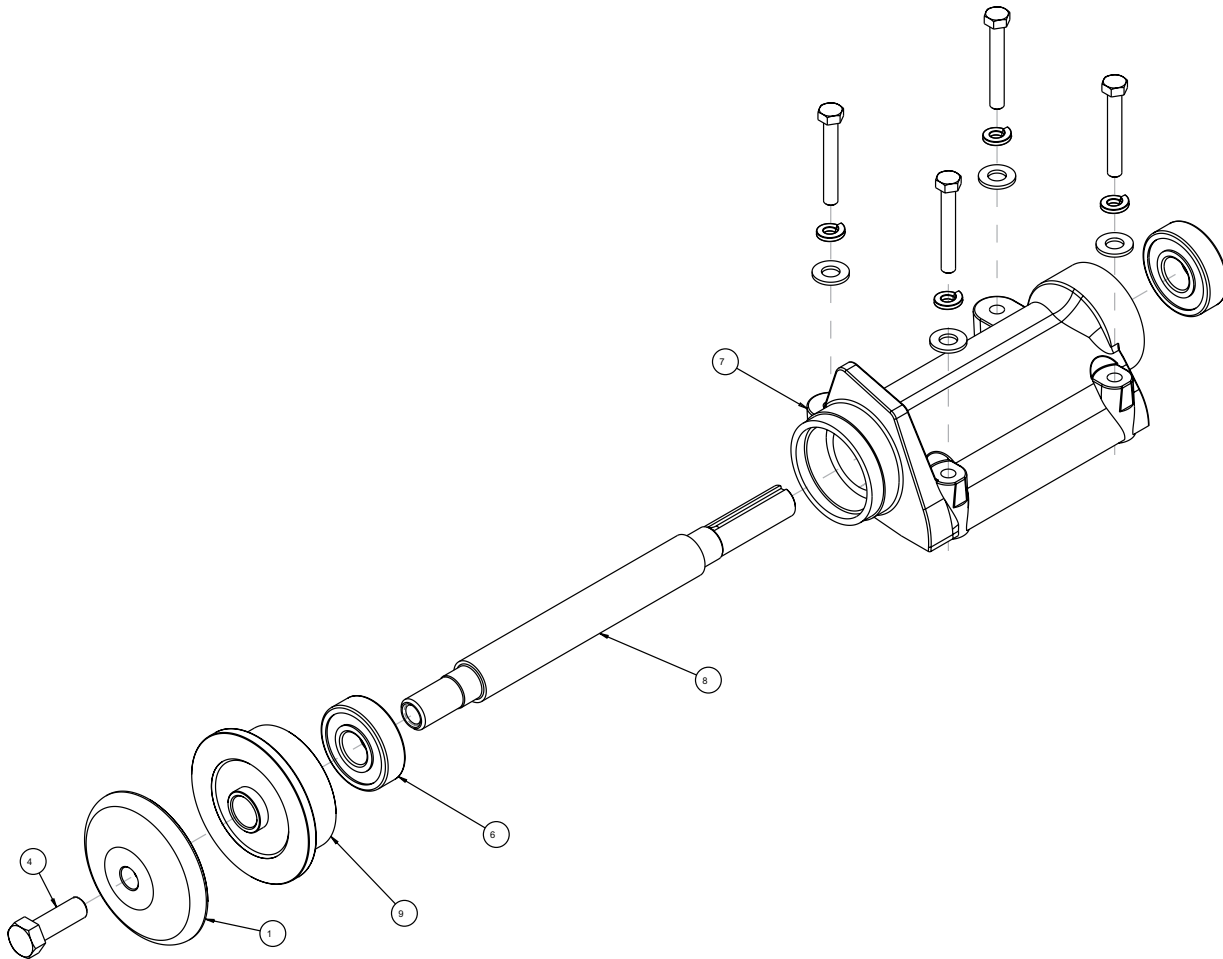





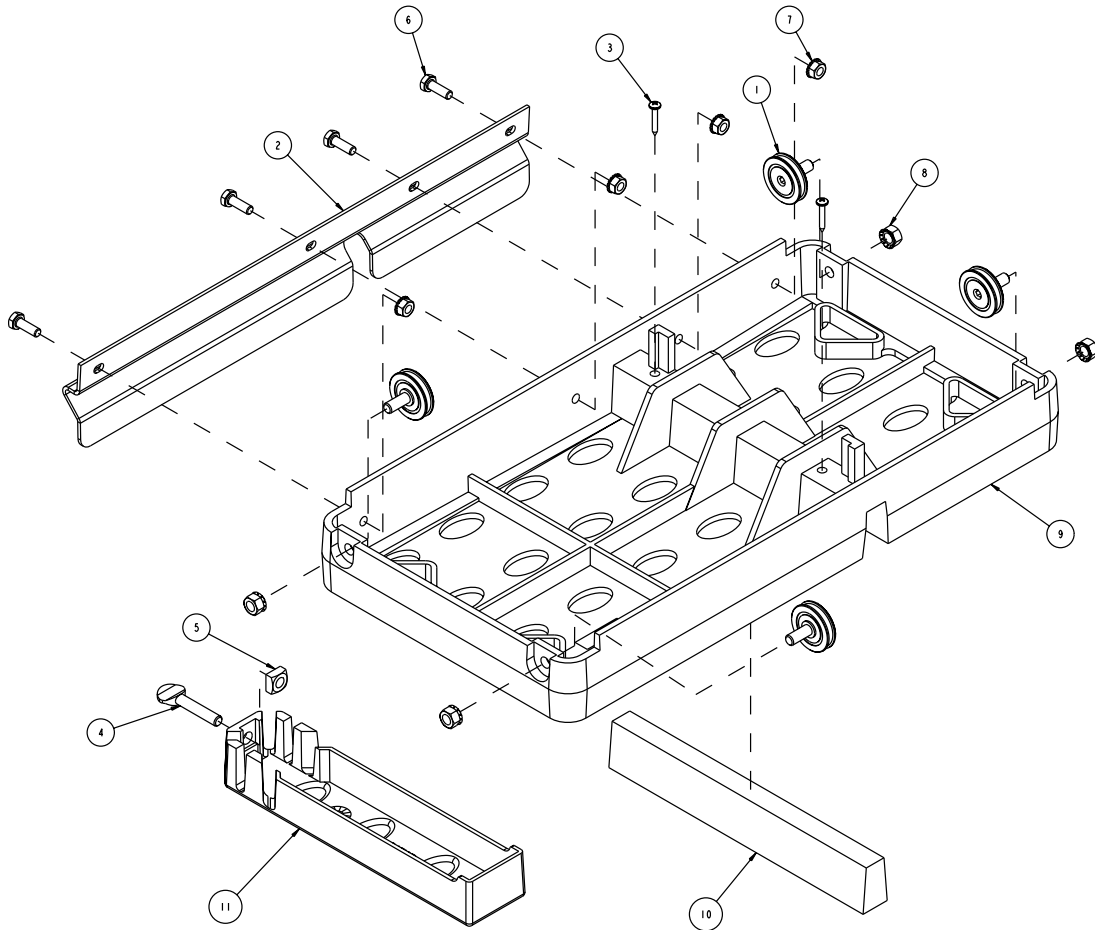

ITEM	DESCRIPTION	PART #	QTY.
1	FLANGE, OUTER	132290	1
2	WASHER, FLAT, SAE, 3/8	150923	4
3	WASHER, LOCK, SPLIT, 5/16	151747	4
4	SCREW, HEX HD 1/2-20X1-1/4	152122	1
5	SCREW, HEX, 5/16-18 X 2-1/4	153951	4
6	BEARING, ARBOR HOUSING	154594	2
7	CASTING, 2000/5000 ARBOR - COMP	154637	1
8	SHAFT, BLADE	154639	1
9	FLANGE, ARBOR, INNER	154640	1

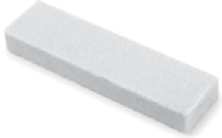
Assy Table Part # 133082



ITEM	DESCRIPTION	PART #	QTY.
1	WHEEL, CONVEYOR CART	133090	4
2	STOP, BACK-CONVEYOR CART	134387	1
3	SCREW, PAN HD PHIL #8 X 1	151047	2
4	SCREW, THUMB 5/16-18 X 1- 1/2	151155	1
5	NUT, SQUARE 5/16 - 18	151156	1
6	SCREW, 1/4 -20 X 3/4 HEX HEAD MACHINE	152370	4
7	NUT, HEX W/WSHR, 1/4 - 20	153941	4
8	NUT, HEX W/WSHR 5/16 - 18	153942	4
9	TABLE, D.C., COMP	158144	1
10	WOOD STRIP, TABLE INSERT	158283	1
11	CASTING, SQUARING ARM - COMP	231276	1

Item	Part #	Description	
1.	152792	Dressing Stick	
2.	128777	MK-10 Wet Cutting Refractory blade for brick	
3.	128652	MK-30 Supreme Grade Blade for Concrete Block	
4.	128744	MK-50 Supreme Grade Blade for Concrete Block	
5.	159629	MK-414PB Supreme Grade Penter Blade for Hard Brick	
6.	153331	Folding Saw Stand	

ORDERING INFORMATION

You may order MK Diamond products through your local MK Diamond distributor or, you may order direct from MK Diamond.

When ordering direct from MK Diamond, please have the following information ready before calling:

- The Model Number of the saw
- The Serial Number of the saw
- Where the saw was purchased and when
- The Part Number for the part(s) being ordered
- The Part Description for the part(s) being ordered

NOTE: There is a \$25.00 minimum order when ordering direct from MK Diamond. A \$6.00 charge will be added to orders having a net billing value under \$50.00. All purchases must be made using VISA, MasterCard or American Express.

All parts may be ordered by calling toll free to – 800 421-5830 or 310 539-5221 and asking for Customer Service. For technical questions, call – 800 474-5594.

RETURN MATERIALS POLICY

To expedite the service relative to the return of a product purchased through MK Diamond, please observe the following:

NOTE: When returning all items, they must have been purchased within the previous twelve (12) months.

- Have the Model Number of the saw
- Have the Serial Number of the saw
- Have the location of where the saw was purchased
- Have the date when the saw was purchased
- Contact Customer Service for approval to return the item(s)
- Obtain a Returned Goods Number (RGA) authorizing the return
- Follow the packaging instructions in the following section
- Ensure your item(s) are prepaid to the destination

For returned items, call toll free to – 800 421-5830 or 310 539-5221 and ask for Customer Service. For technical questions, call – 800 474-5594 or 310 257-2845.

PACKAGING INSTRUCTIONS

- Remove the Cutting Head and Support Angle Assembly
- Dry the saw before shipping
- When packing, include the following: Saw, Diamond Blade, Blade Guard and Support Angle Assembly and Adjustable Cutting Guide (Other Accessories are not required)
- Package the unit in its original container or one of comparable size (do not ship the unit partially exposed)
- Ensure all parts are secured in the packaging to prevent moving

AUTHORIZED SERVICE CENTERS

For quicker repair time, you may contact MK Diamond Customer Service, toll free, at 800 421-5830 or 310 539-5221 for the Authorized Service Center closest to you or visit our web site at www.mkdiamond.com. For technical questions, call – 800 474-5594.

CONTACT

Please contact MK Diamond Products, Inc. Customer Service Department with any questions you might have regarding distributors, parts or service.

Telephone: **(800) 421-5830**

Fax: **(310) 539-5158**

E-mail: **Customer_Service@MKDiamond.com**

Customer Service Hours: **Monday through Friday, 6AM-4PM PST**

MK Diamond Products, Inc.

1315 Storm Parkway

Torrance, CA 90501

MK DIAMOND PRODUCTS, INC. LIMITED WARRANTY

MK DIAMOND PRODUCTS, INC. will guarantee every machine they build, to be free from defects in material and workmanship for (1) one year from date of purchase. The obligation of MK DIAMOND PRODUCTS, INC. under this warranty is limited to the repair or replacement of any parts which, under normal use, prove to be defective in material or workmanship. The parts involved or the unit in question should be returned to MK DIAMOND PRODUCTS, INC. or to a point designated by us, transportation prepaid.

This warranty does not obligate us to bear the cost of labor or transportation charges in connection with replacement or repair of defective parts. Likewise, it shall NOT apply to any unit which has been subjected to misuse, neglect or accident. This warranty does NOT apply to any machine which has been repaired or altered outside our factory.

This warranty does NOT obligate MK DIAMOND PRODUCTS, INC., with respect to items not of our manufacture, such as engines, motors, hydraulics, etc., which are subject to their own guarantees and warranties.

We shall in no event be liable for consequential damages or contingent liabilities arising out of failure of any equipment or parts to operate properly.

© COPYRIGHT 2015, MK DIAMOND PRODUCTS, INC. ALL RIGHTS RESERVED.

The MK Diamond logo is a registered trademark of MK Diamond Products, Inc. and may not be used, reproduced, or altered without written permission. All other trademarks are the property of their respective owners and used with permission.

MK Diamond may have patents, patent applications, trade marks, copyrights of other intellectual property right covering this product in this document.

This manual MUST accompany the equipment at all times. This manual is considered a permanent part of the equipment and should remain with the unit if resold.

The information and specifications included in this publication were in effect at the time of approval for printing.

MK-2000 SERIES
OWNER'S MANUAL, OPERATING
INSTRUCTIONS , & PARTS LIST



MK Diamond Products, Inc.

MK Diamond Products, Inc.
1315 Storm Parkway
Torrance, CA 90501

Toll-Free: (800) 421-5830
Phone: (310) 539-5221
Fax: (310) 539-5158
www.mkdiamond.com